



## DIRTMAG®

### 2-IN-1 DIRT AND MAGNETIC SEPARATORS

**CALEFFI**  
Hydronic Solutions



Heating &amp; Cooling

Components for today's modern hydronic systems



## PRODUCT FEATURES

- Low velocity zone and large dirt capture area:**  
 Pipe velocity slows by a factor of 9 as fluid enters chamber. Unlike strainers which clog and cause increased pressure drop, debris is removed from the flow path and captured in lower bowl area, simplifying and reducing frequency of cleaning.
- Robust mesh construction:**  
 Unique dirt separation mesh uses deflection and gravity to separate dirt particles as small as 5 microns from flow stream. Concentric pattern design has low flow resistance resulting in 85% less pressure drop compared to same size y-strainer.
- Powerful neodymium rare-earth magnets:**  
 Magnetic field attracts and captures microscopic ferrous oxide impurities. Removes 2 ½ times the ferrous oxide compared to other dirt separators.
- Clip-on magnetic ring and convenient purge valve:** Opening purge valve and removing magnetic ring releases captured magnetic impurities and purges all dirt without shutting down the system.
- Top access port:**  
 ½" npt top provides convenient chemical additive dosing port.
- Corrosion resistant:**  
 All components highly resistant to hydronic chemical additives or unstable pH fluid.

### Highly efficient 2-in-1 dirt and magnetic debris separation

DIRTMAG® removes non-ferrous debris from systems as small as 5 microns. Ferrous debris forms in systems when iron or steel corrodes. This abrasive, extremely fine sediment is difficult to remove by traditional methods and can cause damage to heat exchangers and circulators. DIRTMAG® accomplishes 2 ½ times the ferrous oxide removal performance of other dirt separators, delivering up to 100% elimination efficiency.

PRODUCT RANGE - DIRTMAG®

SIZES	MAX. FLOW RATE: (GPM)	CODE		
		NPT	SWEAT	PRESS
1"	10	546306A	546328A	546366A
1¼"	15	546307A	546335A	546367A
1½"	22	546308A	546341A	546368A
2"	39	546309A	546354A	546369A

U.S Patent pending.



DIRTMAG® separators can be purchased with Boiler Treatment Kits, code numbers not listed here. See Caleffi List Price Catalog.

CONSTRUCTION

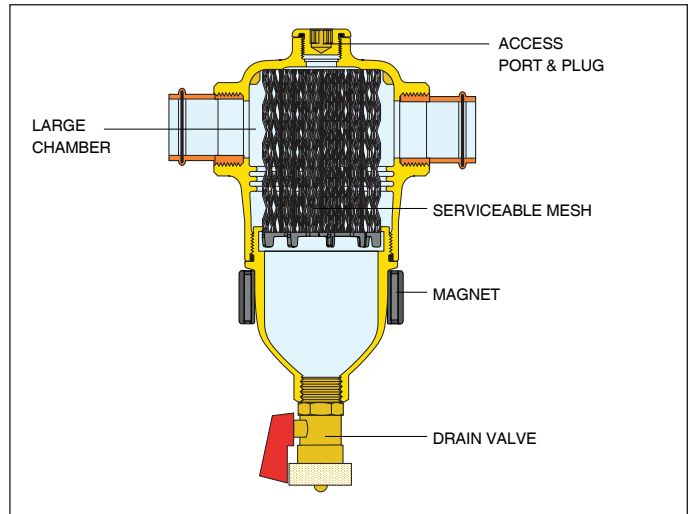

PERFORMANCE

MAX. WORKING PRESSURE	150 psi (10 bar)
WORKING TEMPERATURE RANGE	32 — 250°F (0-120°C)
MAX. PERCENTAGE OF GLYCOL	50%
PARTICLE SEPARATION CAPACITY	5 microns (0.2 mil)
FERROUS IMPURITIES SEPARATION EFFICIENCY	up to 100%

FERROUS & NON-FERROUS DIRT SEPARATION

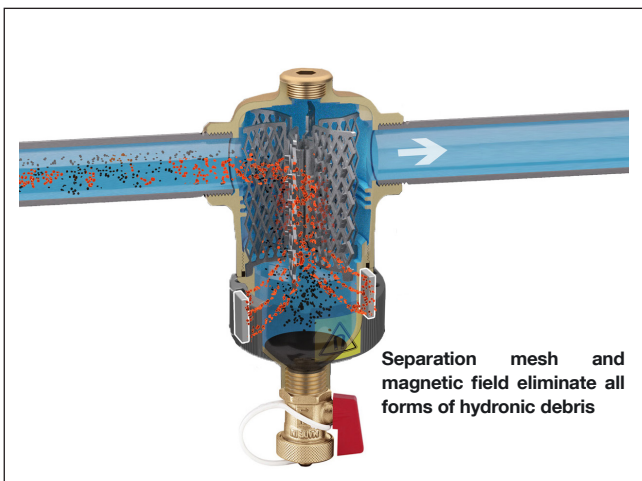

APPLICATION DIAGRAM

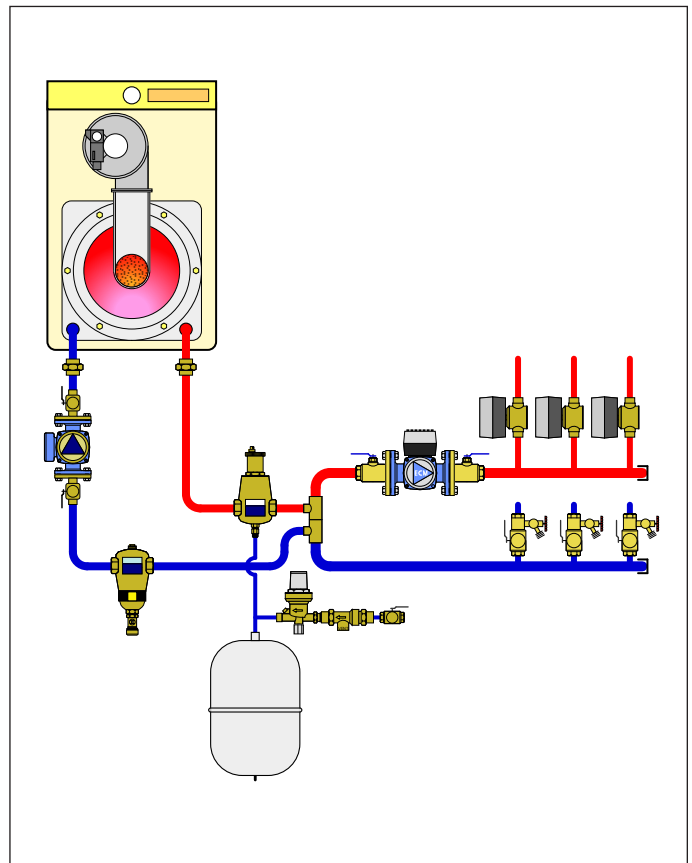

Caleffi Partner:



03504-18 NA

WE RESERVE THE RIGHT TO CHANGE OUR PRODUCTS AND THEIR RELEVANT TECHNICAL DATA, CONTAINED IN THIS PUBLICATION, AT ANY TIME AND WITHOUT PRIOR NOTICE.

Caleffi North America, Inc.  
 sales@caleffi.com · www.caleffi.com  
 © Copyright 2018 Caleffi North America, Inc.