

FlowCal+™ Low-lead compact dynamic flow balancing valve

127 series



Function

The FlowCal+™ compact dynamic flow balancing valve is pressure independent and maintains a fixed flow rate as differential pressures vary. It incorporates an exclusive flow cartridge, made of an anti-scale, low noise polymer. Constructed of DZR low-lead brass, FlowCal+ is ideally suited for use in plumbing applications such as hot water recirculation systems. The built-in check valve protects against circuit thermo-siphoning. The outlet temperature gauge (optional) verifies the fluid temperature in the circuit. The FlowCal+ can also be used in hydronic systems.

The FlowCal+ balancing valve is available with NPT male, sweat, press, PEX crimp and PEX expansion union connections. The union nut makes installation and maintenance fast, easy and efficient for a variety of tailpiece options.

Product range

127 series FlowCal+ compact dynamic automatic balancing valve, with polymer cartridge, includes check valve, optional outlet temperature gauge.....sizes ½", ¾", 1" NPT male, sweat, press, PEX crimp or PEX expansion union connections

Technical specifications

Materials

Body: DZR low-lead brass (<0.25% Lead content)
 Flow cartridge: anti-scale polymer
 Spring: stainless steel
 Seals: peroxide-cured EPDM

Performance

Medium: water, glycol solutions
 Max. percentage of glycol: 50%
 Max. working pressure: 232 psi (16 bar)

Working temperature range: 32-212° F (0-100° C)
 Connections: 1/2", 3/4" and 1" NPT male, sweat, press, PEX crimp or PEX expansion union
 Lay length (press connection): size ½ and ¾ inch: 3 5/8"
 size 1 inch: 4 1/16"
 Flow Rate: 21 fixed flow rate settings ranging from 0.35 - 10 GPM
 Flow Accuracy: ± 10%
 Differential Pressure Control Ranges: 2-14, 2-32, 4-34, 5-35 psid

Optional outlet 2" diameter temperature gauge:
 Scale: 30 - 210° F
 Accuracy: ± 6%

Certifications

1. NSF/ANSI 372, Drinking Water System Components-Lead Content Reduction of Lead in Drinking Water Act, California Health and Safety Code 116875 S.3874, Reduction in Drinking Water Act, Vermont Act 193 - The Lead in Plumbing Supplies Law and Maryland's Lead Free Law HB.372, certified by ICC-ES, file PMG-1360.
2. PEX crimp fittings certified to ASTM F 1807.
3. PEX expansion fittings certified to ASTM F 1960.

US Patent: 7,246,635 B2.

Dimensions

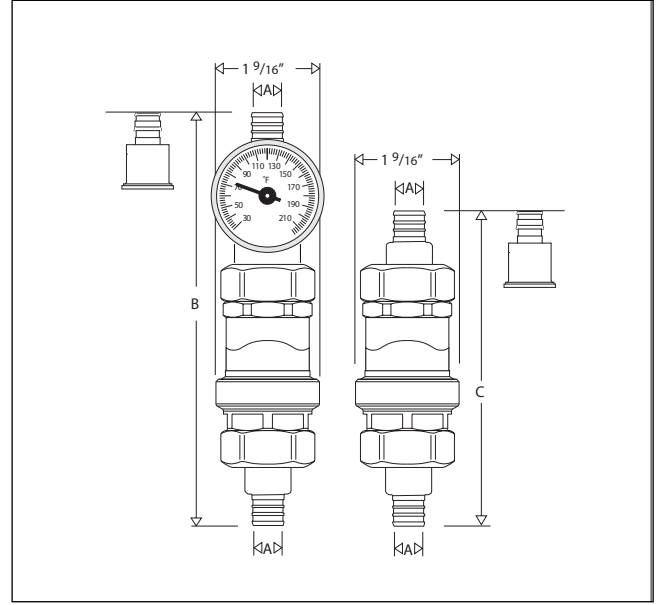
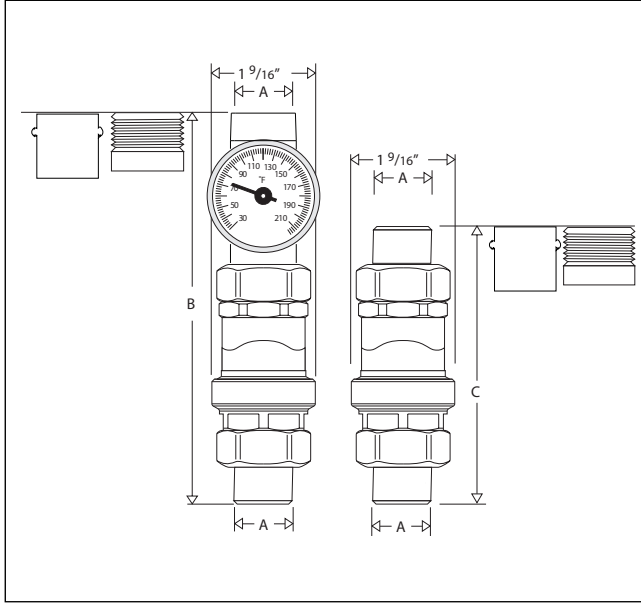

| Code | A (union connections) | B (w/ Gauge) | C (w/o Gauge) | Wt (lb/kg) |
|---------------|--------------------------|-----------------|------------------|---------------|
| 127140AFC ... | 1/2" NPT male | 7 1/8" | ---- | 1.2/0.54 |
| 127141AFC ... | 1/2" NPT male | ---- | 4 7/8" | 1.0/0.45 |
| 127147AFC ... | 1/2" press | 7" | ---- | 1.2/0.54 |
| 127146AFC ... | 1/2" press | ---- | 4 3/4" | 1.0/0.45 |
| 127148AFC ... | 1/2" sweat | 7 1/8" | ---- | 1.0/0.45 |
| 127149AFC ... | 1/2" sweat | ---- | 4 7/8" | 0.8/0.36 |
| 127150AFC ... | 3/4" NPT male | 7 5/16" | ---- | 1.2/0.54 |
| 127151AFC ... | 3/4" NPT male | ---- | 5 11/16" | 1.0/0.45 |
| 127157AFC ... | 3/4" press | 9 5/16" | ---- | 1.2/0.54 |
| 127156AFC ... | 3/4" press | ---- | 7 1/16" | 1.0/0.45 |
| 127158AFC ... | 3/4" sweat | 7 9/16" | ---- | 1.0/0.45 |
| 127159AFC ... | 3/4" sweat | ---- | 5 5/16" | 0.8/0.36 |
| 127160AFC ... | 1" NPT male | 8 1/16" | ---- | 1.4/0.64 |
| 127161AFC ... | 1" NPT male | ---- | 5 13/16" | 1.2/0.54 |
| 127167AFC ... | 1" press | 9 7/16" | ---- | 1.5/0.68 |
| 127166AFC ... | 1" press | ---- | 7 3/16" | 1.3/0.60 |
| 127168AFC ... | 1" sweat | 8 9/16" | ---- | 1.2/0.54 |
| 127169AFC ... | 1" sweat | ---- | 6 5/16" | 1.0/0.45 |

| Code | A (union connections) | B (w/ Gauge) | C (w/o Gauge) | Wt (lb/kg) |
|---------------|--------------------------|-----------------|------------------|---------------|
| 127143AFC ... | 1/2" PEX expansion | 7 7/8" | ---- | 1.2/0.54 |
| 127142AFC ... | 1/2" PEX expansion | ---- | 5 5/8" | 1.0/0.45 |
| 127145AFC ... | 1/2" PEX crimp | 7 3/4" | ---- | 1.2/0.54 |
| 127144AFC .. | 1/2" PEX crimp | ---- | 5 1/2" | 1.0/0.45 |
| 127153AFC ... | 3/4" PEX expansion | 8 13/16" | ---- | 1.2/0.54 |
| 127152AFC ... | 3/4" PEX expansion | ---- | 6 9/16" | 1.0/0.45 |
| 127155AFC ... | 3/4" PEX crimp | 8 1/16" | ---- | 1.2/0.54 |
| 127154AFC ... | 3/4" PEX crimp | ---- | 5 13/16" | 1.0/0.45 |
| 127163AFC ... | 1" PEX expansion | 9 11/16" | ---- | 1.5/0.68 |
| 127162AFC ... | 1" PEX expansion | ---- | 7 7/16" | 1.3/0.60 |
| 127165AFC ... | 1" PEX crimp | 8 11/16" | ---- | 1.5/0.68 |
| 127164AFC ... | 1" PEX crimp | ---- | 6 7/16" | 1.3/0.60 |

FlowCal Compact Dynamic Automatic Flow Balancing Valves

The FlowCal+™ flow cartridge is composed of a cylinder, a spring-loaded piston, and a combination of fixed and variable geometric orifices through which the fluid flows. These variable orifice sizes increase or decrease by the piston movement, contingent on the system's fluid thrust. A specially calibrated spring counteracts this movement to regulate the amount of fluid that will pass through the valve orifices, maintaining a constant flow rate in the circuit.

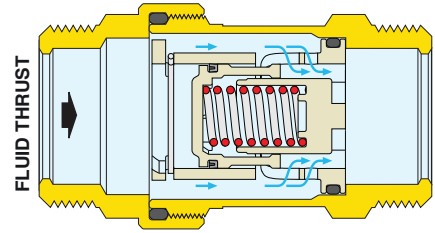

Below the differential pressure control range (< 2 psid)*

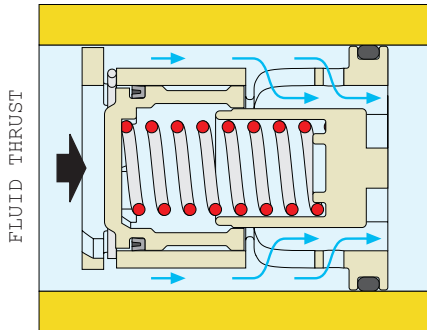

In this case, the spring-loaded regulating piston remains in equilibrium without compressing the spring and gives the fluid the maximum free flow area. When below the differential pressure control range the piston acts as a fixed orifice and thus the flow rate through the FlowCal depends only on the differential pressure.

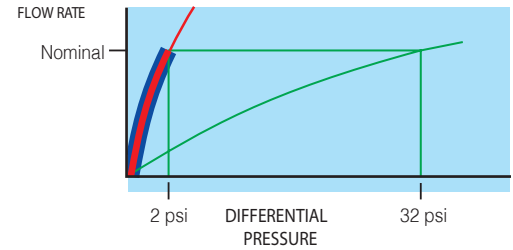
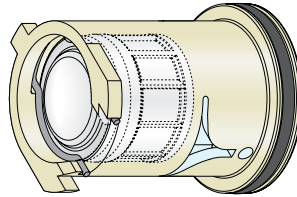

Range Δp 2-32 psi

Within the differential pressure control range (2 - 32 psid)*

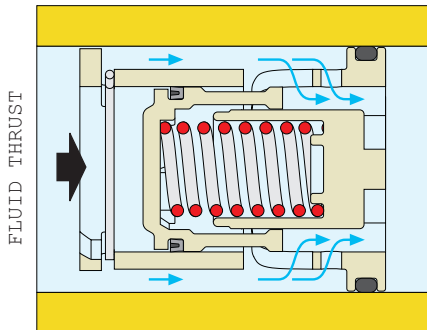

If the differential pressure is within the control range, the spring-loaded piston is positioned to give the fluid a free flow area permitting regular flow at the **nominal rate** for which the FlowCal is set up.

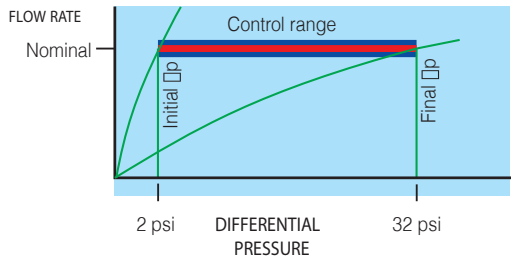
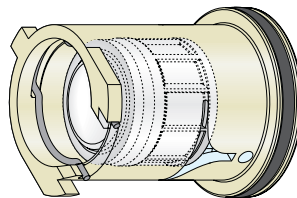

Above the differential pressure control range (> 32 psid)*

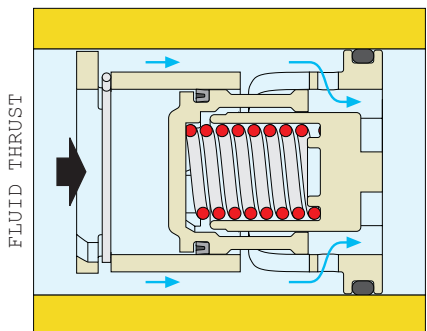

In this case, the spring-loaded piston fully compresses a spring and leaves only the fixed orifice for the fluid to pass through. The flow rate through the FlowCal depends only on the differential pressure.

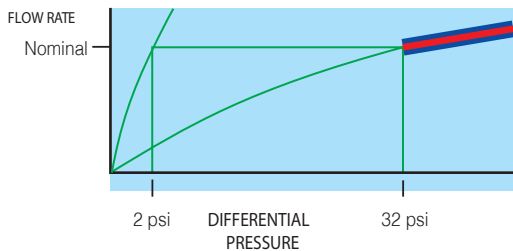
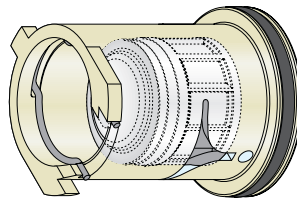

Range Δp 2-32 psi

*These values are for this example. The same logic applies to the other Differential Pressure Control Ranges: 2 - 14, 4 - 34, and 5 - 35 psid.

Construction details

Polymer flow cartridge

The flow rate cartridge is made of an anti-scale polymer, specially engineered for use in cooling, heating and domestic water systems, to prevent mineral buildup in a wide range of working temperatures. It features high resistance to the abrasion caused by continuous fluid flow, is insensitive to the deposit of scale and is fully compatible with glycols and additives used in circuits.

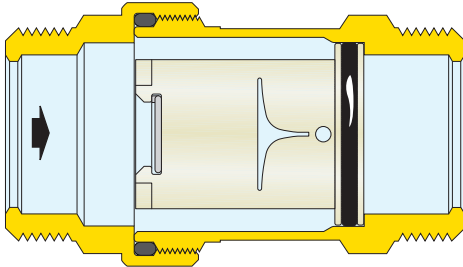

Exclusive design

With its exclusive design, the flow cartridge is able to accurately control the flow rate in a wide range of operating pressures. A special internal chamber acts as a damper for the vibrations triggered by the fluid flow, allowing low noise operating conditions to the device.

For these reasons it can be used in systems on zone branch circuits or directly at the terminals.

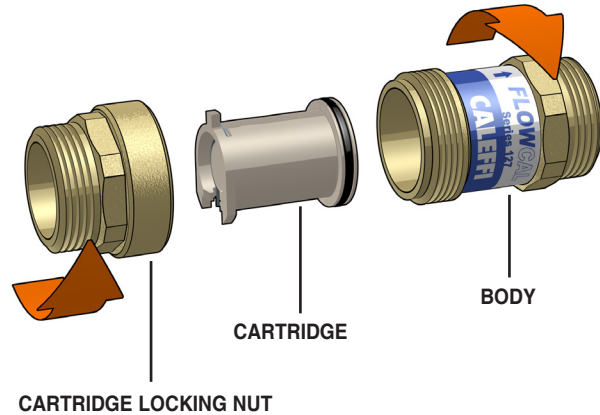

Order Code Numbering for FlowCal+ 127 series

| Code | Description | Code | Description | Code | Description |
|--------------|------------------------|--------------|------------------------|--------------|------------------------|
| 127140AFC... | ½" NPT male, Gauge | 127150AFC... | ¾" NPT male, Gauge | 127160AFC... | 1" NPT male, Gauge |
| 127141AFC... | ½" NPT male, No gauge | 127151AFC... | ¾" NPT male, No gauge | 127161AFC... | 1" NPT male, No gauge |
| 127143AFC... | ½" PEX exp., Gauge | 127153AFC... | ¾" PEX exp., Gauge | 127163AFC... | 1" PEX exp., Gauge |
| 127142AFC... | ½" PEX exp., No gauge | 127152AFC... | ¾" PEX exp., No gauge | 127162AFC... | 1" PEX exp., No gauge |
| 127145AFC... | ½" PEX crimp, Gauge | 127155AFC... | ¾" PEX crimp, Gauge | 127165AFC... | 1" PEX crimp, Gauge |
| 127144AFC... | ½" PEX crimp, No gauge | 127154AFC... | ¾" PEX crimp, No gauge | 127164AFC... | 1" PEX crimp, No gauge |
| 127147AFC... | ½" press, Gauge | 127157AFC... | ¾" press, Gauge | 127167AFC... | 1" press, Gauge |
| 127146AFC... | ½" press, No gauge | 127156AFC... | ¾" press, No gauge | 127166AFC... | 1" press, No gauge |
| 127148AFC... | ½" sweat, Gauge | 127158AFC... | ¾" sweat, Gauge | 127168AFC... | 1" sweat, Gauge |
| 127149AFC... | ½" sweat, No gauge | 127159AFC... | ¾" sweat, No gauge | 127169AFC... | 1" sweat, No gauge |

All fittings are union style.

| Flow rate (GPM) | Last 3 digits (AFC__) | ΔP control ranges (psid) |
|-----------------|-----------------------|--------------------------|
| 0.35 | G35 | 2 - 14 |
| 0.50 | G50 | |
| 0.75 | G75 | |
| 1.00 | 1G0 | 2 - 32 |
| 1.30 | 1G3 | |
| 1.50 | 1G5 | |
| 1.75 | 1G7 | |
| 2.00 | 2G0 | |
| 2.20 | 2G2 | |
| 2.50 | 2G5 | |

| Flow rate (GPM) | Last 3 digits (AFC__) | ΔP control ranges (psid) |
|-----------------|-----------------------|--------------------------|
| 2.60 | 2G6 | 2 - 32 |
| 3.00 | 3G0 | |
| 3.50 | 3G5 | |
| 4.00 | 4G0 | |
| 4.50 | 4G | |
| 5.00 | 5G0 | |
| 6.00 | 6G0 | 4 - 34 |
| 7.00 | 7G0 | |
| 8.00 | 8G0 | |
| 9.00 | 9G0 | 5 - 35 |
| 10.00 | 10G | |

Hot water recirculation

Balanced example

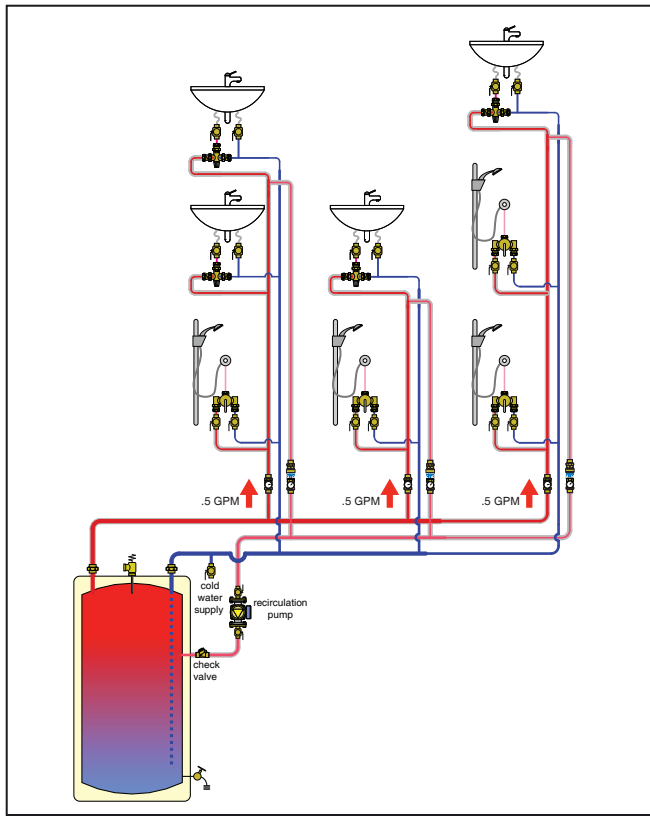

Unbalanced example

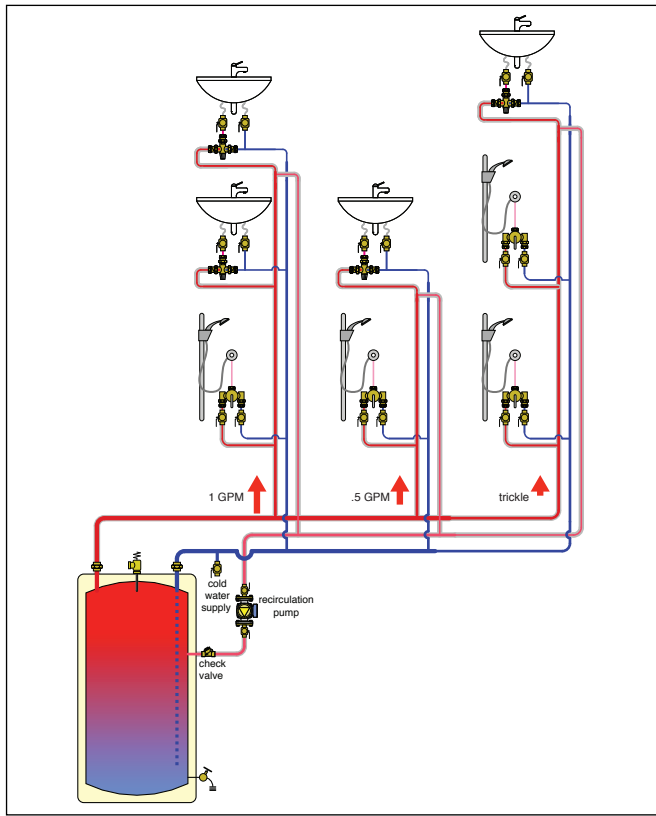

Balancing made fast, easy, and accurate with the Caleffi FlowCal+ 127 series balancing valve

Hot water recirculation systems are designed to minimize wait time for hot water to arrive when a fixture is opened. Systems left unbalanced or improperly balanced result in wasted water down the drain, a costly and environmentally unfriendly situation - not to mention the undesired annoyance placed on building occupants. Multiple hot and cold water risers are supplied from common hot and cold water mains. The number and type of fixtures served by each set of risers will often be different. A recirculation riser accompanies each set of hot and cold risers. A single circulator provides recirculation flow through the entire system. This type of piping network is similar to a 2-pipe direct return distribution system for hydronic heating. Because of differences in the lengths or sizes of both the main piping and riser piping, the recirculation flow through each set of risers is likely to be different. This can lead to different temperature drops between the beginning of a given hot water riser and the end of its associated return riser. This may cause the hot water temperature arriving at a distant fixture to be insufficient for the intended usage. This situation can be corrected by “balancing” the recirculation flow between the various sets of risers. The goal of such balancing is to establish recirculation flow rates that create equal temperature drop between the start of each hot water riser and the end of its associated return (recirculation) riser.

Balancing is enabled with the FlowCal pressure independent low-lead balancing valve, with fixed flow rate, presuming riser flow rates have been computed in advance. These valves will control to the design flowrate without the worry of pressure differentials. The valves are multi-functional with built-in check valve to protect against circuit thermo-siphoning, an built-in filter screen and an optional outlet temperature gauge to verify water temperature.

SPECIFICATION SUMMARY

127 series

Compact dynamic automatic pressure independent flow balancing valve with polymer flow cartridge FlowCal+. Connections ½", ¾", 1" NPT male, sweat, press, PEX crimp and PEX expansion union. PEX crimp fittings must comply with ASTM F 1807. PEX expansion fittings must comply with ASTM F 1960. DZR low-lead brass body (<0.25% lead content) certified by ICC-ES file PMG-1360. Anti-scale polymer cartridge. Stainless steel spring. Peroxide-cured EPDM seals. Water and up to 50% maximum glycol solutions. Maximum working pressure 230 psi (16 bar). Working temperature range 32 to 212 degrees F (0 to 100 degrees C). Δp range 2–35 psi. Range of available flow rates for all connection sizes 0.35 - 10.00 gpm. Accuracy ±10%. Provide with optional outlet temperature gauge, 2 inch diameter, 30 to 210 degrees F scale, accuracy ±6%.

We reserve the right to change our products and their relevant technical data, contained in this publication, at any time and without prior notice.



Caleffi North America, Inc.
3883 W. Milwaukee Road
Milwaukee, WI 53208
Tel: 414-238-2360 · Fax: 414-238-2366
sales@caleffi.com · www.caleffi.com
© Copyright 2020 Caleffi North America, Inc.