

# PLUMBVENT™

## Low-lead automatic air vent

NA502640A



### Function

Float type automatic air vent designed to vent air from water at high points in plumbing system piping. Example applications include risers, domestic hot water storage tanks and recirculation system pump inlets.

The automatic air vent is installed in the vertical position in parts of the system where a concentration of air pockets is to be expected. It is supplied complete with a safety hygroscopic cap that automatically closes the air discharge in case of contact with water.

This vent is certified by ICC-ES to be in compliance with the International Plumbing Code (IPC), International Residential Code (IRC), Uniform Plumbing Code (UPC), National Plumbing Code of Canada (NPC). It is certified by ICC-ES to be in compliance with standard NSF/ANSI 372-2011, California Health and Safety Code 116875 S.3874 (AB1953), and Vermont S152.

### Product Range

Code NA502640A Low-lead automatic air vent with threaded connections.....size 1/2" NPT male

### Technical specification

**Materials** - Body & cover: DZR low-lead brass (<0.25% Lead content)  
 - Seals: peroxide-cured EPDM  
 - Float: Moplen EP548S

**Performance**  
 Suitable fluids: Water  
 Max. working pressure: 150 psi (10 bar)  
 Max. discharge pressure: 90 psi (6 bar)  
 Max. discharge flow rate: 1.75x10<sup>-9</sup> scfm (50 NI/m)  
 Max. working temperature: 240°F (115°C)

### Certifications

NSF/ANSI 372-2011, Drinking Water System Components-Lead Content Reduction of Lead in Drinking Water Act, California Health and Safety Code 116875 S.3874 (AB1953), Reduction of Lead in Drinking Water Act and Vermont S152, certified by ICC-ES, file PMG-1360.

### Connections

- NPT male: 1/2"

### Dimensions

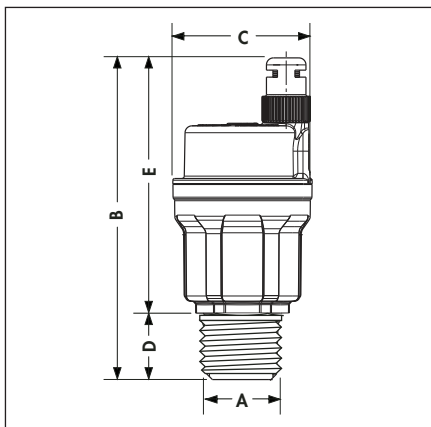

Code	A	B	C	D	E	Wt (lb)
NA502640A	1/2" MNPT	3 5/8"	1 9/16"	3/4"	2 7/8"	0.6

### Air flow

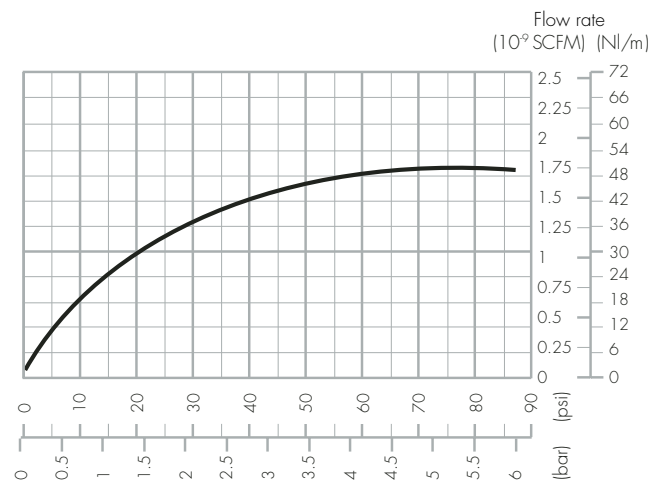

## Typical application drawings

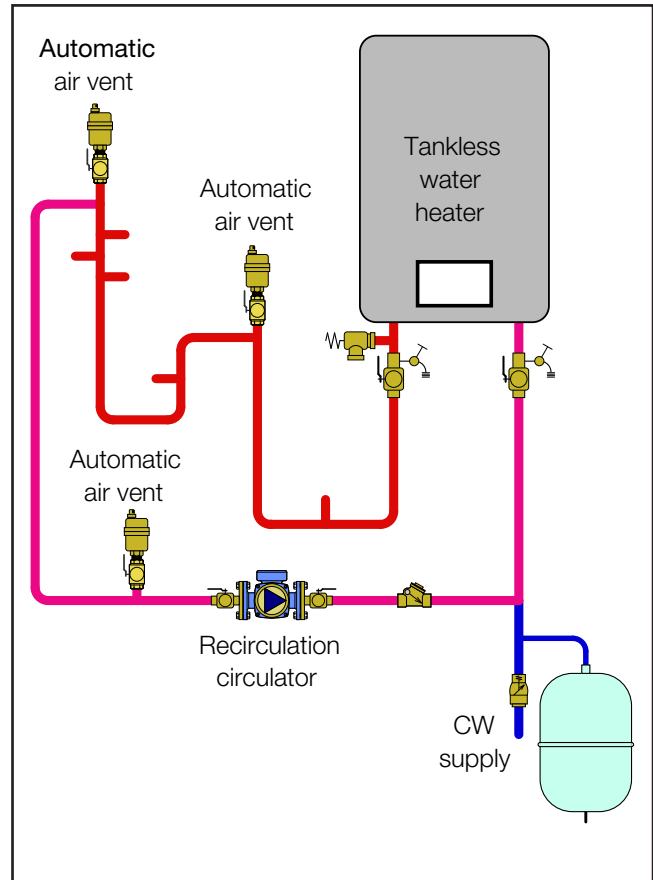
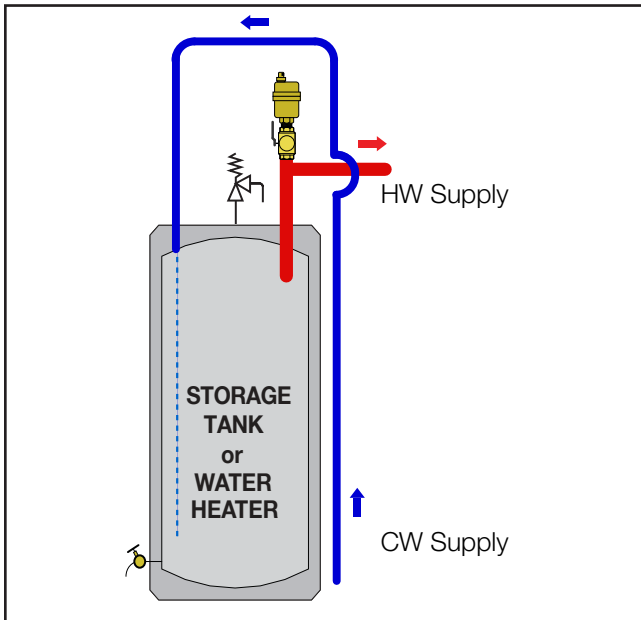

### Construction details

#### • Operating mechanism

The function of this device is guaranteed by an operating mechanism specially designed to vent when system pressure is high.

#### • Antivibration and antirotation system on the float

This guarantees that in the rest position the air relief valve will not be affected by any movement of the float.

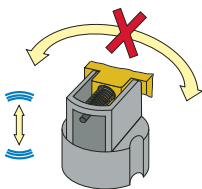
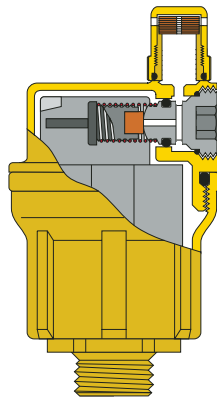

### Operating instructions

The automatic air vent comes complete with a safety hygroscopic cap that automatically closes the air discharge in case of contact with water. The hygroscopic cap does not provide an airtight seal, even when closed. If pressure testing is required, replace the hygroscopic cap with a plastic cap (Caleffi code R56214) or install an isolation valve beneath the vent. For normal automatic venting, this cap should be screwed down finger tight.

## SPECIFICATION SUMMARIES

### NA502640A

Automatic air vent. 1/2" threaded NPT male connection. DZR low-lead brass body and cover (<0.25% lead content), meets requirements of IPC, IRC, UPC, NPC and ANSI/NSF 372-2011, California Health and Safety Code 116875 S.3874 (AB1953), and Vermont S152, as certified by ICC-ES. Moplen EP548S float and peroxide-cured EPDM seals. Maximum working pressure 150 psi (10 bar). Maximum discharge pressure 90 psi (6 bar). Maximum working temperature 240°F (115°C). Float with anti-rotation and anti-vibration system. Vertical discharge. Provide with inlet isolation valve, separately-sourced and field installed.

*We reserve the right to change our products and their relevant technical data, contained in this publication, at any time and without prior notice.*



Caleffi North America, Inc.  
3883 W. Milwaukee Road  
Milwaukee, WI 53208  
Tel: 414-238-2360 · Fax: 414-238-2366  
sales@caleffi.com · www.caleffi.com  
© Copyright 2018 Caleffi North America, Inc.