

January 2017
20

*idronics*TM

JOURNAL OF DESIGN INNOVATION FOR HYDRONIC PROFESSIONALS

Documenting Hydronic Systems

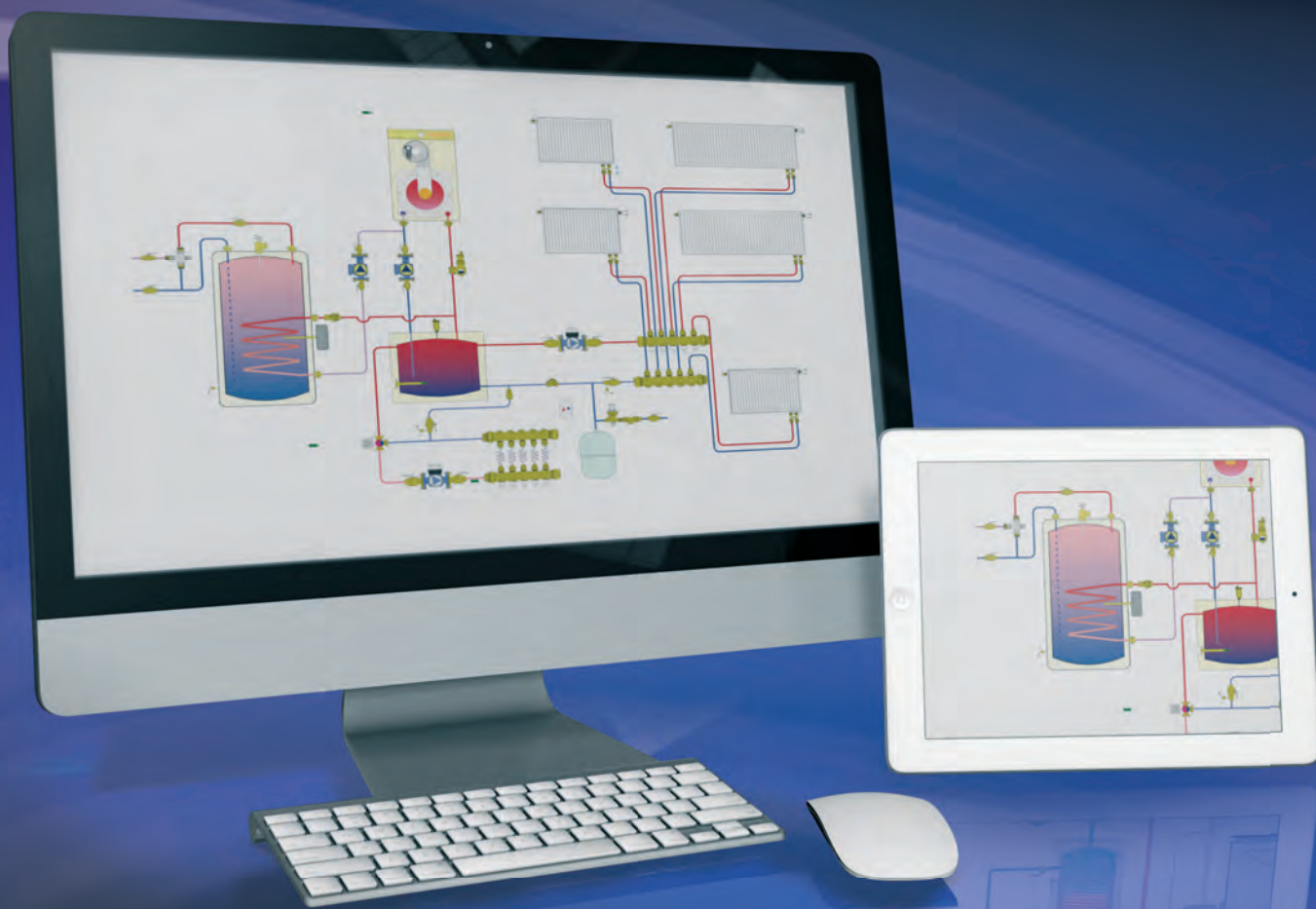

G; CALEFFI

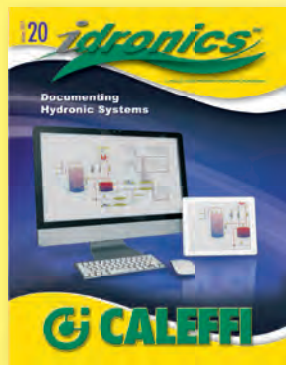

A Technical Journal
from
Caleffi Hydronic Solutions

CALEFFI NORTH AMERICA, INC

3883 W. Milwaukee Rd
Milwaukee, Wisconsin 53208 USA

Tel: 414-238-2360
FAX: 414-238-2366

E-mail: idonics@caleffi.com
Website: www.caleffi.com

To receive future idronics issues
FREE, register online www.caleffi.com

© Copyright 2017
Caleffi North America, Inc.
Printed: Milwaukee, Wisconsin USA



Caleffi North America, Inc.
3883 W. Milwaukee Rd
Milwaukee, Wisconsin 53208
T: 414.238.2360 F: 414.238.2366

Dear Hydronic and Plumbing Professional,

Years ago, while starting out on my own, I bought a twenty-year-old fully furnished home. Furniture, appliances, lawn equipment, electrical tools, party line phone, and even a kitchen range with a retractable cooktop!

The house had been owned by a self-reliant engineer who had passed away, but not before creating detailed records of how equipment in the house operated. He kept carefully maintained files of operating instructions and service records, plus handwritten notes on nearly every mechanical device associated with that house. One of those notes even stated that the cranky chainsaw needed "just 1 prime, not 3, before starting." I was grateful for his meticulous records as the equipment and appliances aged and required maintenance.

We've all experienced situations where carefully prepared instructions helped quickly resolve questions about installing or maintaining some device or system. Many of us can also recall the frustration and wasted time incurred when something didn't operate correctly, but we had little or no documentation to help resolve the problem.

Hydronic heating and cooling systems, especially those that are custom designed, can create challenging maintenance situations for those not familiar with the equipment or how it has been assembled into a system. Without proper documentation, thousands of dollars' worth of hardware can be put in a precarious situation where no one feels competent to repair the system when something doesn't operate as expected.

To avoid such a situation, it's important to document all hydronic systems. In this issue of idronics we discuss how to do this. Specific emphasis is placed on piping schematics, electrical schematics and descriptions of operation.

We hope you enjoy this 20th issue of idronics and encourage you to send us any feedback by e-mailing us at idonics@caleffi.com.

For prior issues, please visit us at www.caleffi.com. There you can download the PDF files. You can also register to receive printed copies of future issues.

Mark Olson

General Manager & CEO

INDEX

1. INTRODUCTION

2. WHAT IS PROPER SYSTEM DOCUMENTATION?

3. TOOLS AVAILABLE FOR DOCUMENTATION

4. CREATING PIPING SCHEMATICS

5. ELECTRICAL SCHEMATICS

6. DESCRIPTION OF OPERATION

7. ADDITIONAL DOCUMENTATION

8. EXAMPLE SYSTEMS

SUMMARY

APPENDIX A1: CALEFFI COMPONENT

SYMBOL LEGEND

APPENDIX A2: GENERIC COMPONENT

SYMBOL LEGEND

APPENDIX B: SUGGESTED SYMBOL LEGEND

FOR COMMON ELECTRICAL COMPONENTS

APPENDIX C: CALEFFI RELAY SYMBOL LEGEND

Disclaimer: Caleffi makes no warranty that the information presented in idronics meets the mechanical, electrical or other code requirements applicable within a given jurisdiction. The diagrams presented in idronics are conceptual, and do not represent complete schematics for any specific installation. Local codes may require differences in design, or safety devices relative to those shown in idronics. It is the responsibility of those adapting any information presented in idronics to verify that such adaptations meet or exceed local code requirements.

Mixed Sources
Products from well-managed
forests, controlled sources and
recycled wood or fiber.



Documenting Hydronic Systems

1. INTRODUCTION

Imagine yourself as an HVAC service technician. You've been dispatched to a "no heat" call in the early morning hours of a cold January day. You are not familiar with the system that you've have been sent to repair. You don't know who installed it, or who services it.

You arrive at the site and are escorted to the mechanical room by the homeowner, who is obviously concerned about how quickly you can restore heat to his home and comfort to his family.

As you enter the basement mechanical room, you see numerous pieces of mechanical equipment, including a wall-hung boiler, several circulators, lots of piping and valves, and the control system shown in figure 1-1.

Figure 1-1

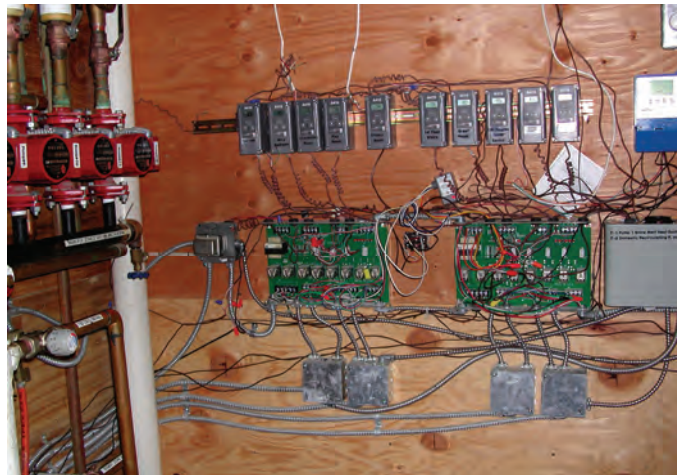

You stand in amazement for a few moments, just looking around. During that time, you hear a relay click, see some LEDs flashing on one of the controllers, and hear the boiler fire, remain on for 30 seconds, and then shut off. The sheer amount of hardware in the mechanical room implies that it was an expensive installation.

Meanwhile, the owner is standing behind you in his bathrobe, expecting you to quickly identify the problem and restore the system to proper operation.

You honestly have no idea of what "proper" operation of this system means, other than it is supposed to produce heat. You're not sure how to begin diagnosing the problem(s).

The homeowner hasn't paid much attention to the system other than paying the monthly fuel bills, and turning the thermostats up and down. Still, he emphasizes that neither he nor anyone else has made changes to the system that could possibly have caused the current problem. He also tells you that he has only lived in the house for three years and has no idea of who installed the system. However, he insists that the system has been "serviced" each fall by a local company that supplies the propane for the boiler. Still, there are no indications of what service work was performed.

You walk around the mechanical room looking for any information that might show how the overall system was designed or installed, and what the settings of the controller should be. No such information can be found.

Figure 1-2



What lies ahead is several hours of trying to learn what the original designer or installer had in mind when the system was installed. You are trying to first determine how the system *should* operate when everything is normal. Only then can you try to pinpoint what is causing it to not operate as expected.

The house is getting progressively cooler as time passes and the system is not delivering heat. You start to wonder if you should make arrangements for temporary electric space heaters in case water pipes in some areas of the building approach freezing temperatures. You wish you had some kind of “road map” that might show you what the original installer’s intent was, rather than tracing piping circuits, wiring and numerous adjustments to several independently operating controls in the system. You are concerned that any control adjustments you make without a clear understanding of how the system was intended to operate might make the present situation worse.

IT DOESN'T HAVE TO BE THIS WAY

This is obviously not a situation that any HVAC service technician wants to find themselves in. It gives the appearance, at least to the owner, that they, and perhaps the company they work for, are incompetent.

Although most building owners expect that their heating or cooling systems will require service, they don’t understand why any reasonably competent HVAC service technician should not be able to quickly identify the problem(s), and fix them. They are used to well-trained service technicians repairing their vehicles, their refrigerator and their computers.

From the owner’s perspective, why should it be necessary to spend hours “reconstructing” the original intended operation of the system, and only then attempt to restore to this operation? Why should the owner be expected to pay for that time?

Such situations can also lead a rapid spread of negative experience as the owner and his family describe their situation to others. The “take-away” of such conversations will likely be that hydronic heating systems are complex, expensive, break down and are difficult to service. Such conversations can create lasting bad impressions among people who may influence future decisions on heating systems for other buildings. Consumers obviously have many choices when it comes to selecting heating and cooling systems, and even minor bad impressions create legitimate doubts that sway decisions.

Unfortunately, scenarios similar to the above occur multiple times during each year.

In today’s market, nearly all manufacturers provide information on the proper installation and servicing of the *components* they sell. This information is often shipped with the product, and usually available online.

However, a hydronic system is a *combination* of many individual components, and in many cases, a very *unique* combination. There are no manufacturers that currently sell complete hydronic systems along with associated installation, commissioning and servicing instructions. It falls to the designer to select the components needed in the system, and communicate how those components are to be installed relative to each other. The designer also must ensure compatibility between all selected components. The challenge is to create a stable, efficient and reliable system that is often an assembly of several hundred individual components.

This is a task that some individuals savor, while others view it as far less important than maximizing the profit associated with the installation.

It is also the designer’s responsibility to *clearly communicate* how the selected hardware is to be installed and properly commissioned. The very best system design is of marginal value when it’s only “stored” in the designer’s mind.

The level of detail used in documenting the design can make the difference between thousands of dollars’ worth of hardware that works harmoniously and efficiently as a complete system, versus an assembly of perfectly good hardware that never achieves its full performance potential, creates frequent service calls and repeatedly frustrates all parties involved.

Beyond its use for installation and servicing, good system documentation adds significant value to the project. It demonstrates knowledge, professionalism, commitment to proper system installation and operation, and lasting value for a purchase that often costs thousands of dollars. Well-prepared documentation sets the heating professional who offers it apart from competitors that don’t care enough or know enough to create it.

This issue of *idronics* describes modern methods for properly documenting the *technical* nature of hydronic heating and cooling systems intended for residential and light commercial installations. This documentation helps

ensure proper installation, proper commissioning and efficient serviceability for the system over its full life.

Beyond technical documentation, consulting engineers often have to prepare documents that detail bidding processes, contractual procedures, payment schedules and other legal aspects of the parties involved with designing, installing and commissioning the system. This documentation varies considerably depending on the scope of the project and the client (i.e., private owner, corporate owner or a government agency). Such documentation is not covered in this issue.

Figure 1-3

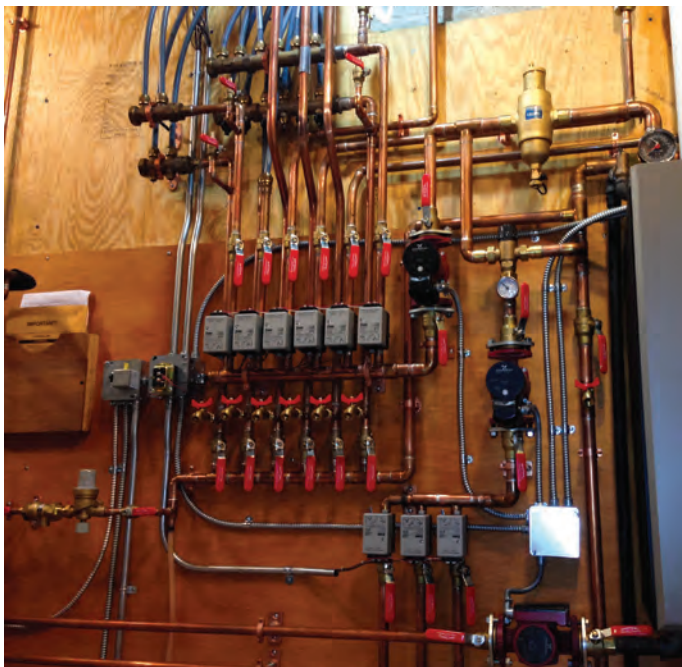

Credit: Slovinski Plumbing & Heating

2. WHAT IS PROPER SYSTEM DOCUMENTATION?

This question is like asking: What is a proper *resume*? What is a proper *will*? Or what is a proper *contract* between a heating professional and a client? Opinions obviously vary on such issues. Likewise, opinions vary on what documentation is insufficient, adequate or even superfluous regarding design, installation, commissioning and servicing of a hydronic heating or cooling system.

Experience has shown that problems are more likely to occur in projects where the documentation *lacks sufficient detail*, or is *poorly communicated*. Such situations have occurred many times across the industry spectrum from wholesalers and manufacturer's representatives who are asked for design assistance, to installers who often do their own design, to professional engineers hired to provide sufficient design information for proper installation and commissioning of a system.

One example of insufficient documentation is a professional engineer who provides a piping schematic for a hydronic heating system along with a minimally detailed description of operation, but doesn't provide specification of the control hardware that should be used to achieve the intended operation. Assuming that the design documents provided by the engineer are accepted based on the scope of work under which the engineer was retained, responsibility for completing the control system is evidently (and sometimes unwittingly) passed to the installer. If the installer is not experienced with the intended control requirements, they often seek assistance from a manufacturer's representative who represents products that *might* be able to provide the intended control functions. The manufacturer's representative may *suggest* certain products to the installer, but at the same time, they may not provide complete documentation on how those products must interface to other devices in the system, how they should be programmed, or exactly where devices such as temperature sensors should be installed. Understandably, the manufacturer's representative is not wanting to insert themselves into what could be construed as the design process, and in so doing, take on responsibility for proper operation of the system.

At that point, who becomes responsible for ensuring that the right controls are purchased, properly installed and appropriately adjusted: the owner, the designer, the installer, or the manufacturer's representative?

Although it is possible that a good solution could be attained through cooperation and communication of all parties, it is just as likely that assumptions about who is

responsible to complete the control system will lead to misunderstandings, callbacks, “finger pointing,” or even litigation if the system operates in a manner far different than what was expected.

While proper documentation is not a guarantee that such problems can’t develop, it certainly lowers the chances by reducing the ambiguity of what the final system should be and how it should operate.

Figure 2-1



Courtesy of American Plumbing, Heating and Solar Inc.

To gain a better perspective on what constitutes proper documentation, it’s important to start with the *objective* of that documentation.

From the standpoint of *design*, the objective is to define all non-commodity devices within the system in a manner that clearly represents the designer’s selections, intended assembly and desired operating conditions.

“Non-commodity devices” refers to hardware such as heat source(s), chillers, circulators, heat exchangers, tanks, piping materials and size, air and dirt separators, mixing valves, specialty valves, manifold stations, chimneys, vent connectors, temperature sensors and all safety devices. These are all devices that must be sized and selected to fulfill specific performance requirements in the system.

Commodity items usually include common pipe fittings, wiring hardware and mechanical fasteners. However,

even within these categories designers should provide a detailed specification for any hardware that is required for atypical service. Examples include electrical conductors for use in high-temperature surroundings; fasteners for securing especially heavy equipment; and specialty pipe fittings for inserting temperature sensors, dielectric fittings or vibration-absorbing piping supports.

In addition to specific hardware, it’s important that designers also specify any settings or calibrations, such as the rated pressure of a relief valve, or the temperature setting of the boiler’s high limit controller.

FUNDAMENTAL DOCUMENTATION

The documentation that collectively achieves these objectives includes:

- A piping schematic of the entire system that identifies all non-commodity components
- An electrical schematic of the entire system that identifies all non-commodity components
- A description of operation for all system operating modes
- Listings (a.k.a. “schedules”) of all non-commodity components
- One or more scaled drawings of building floor plans that show the location of heat emitters
- One or more tables that show the desired operating flow rates and temperatures to which the system should be adjusted when it is commissioned
- Possible use of photos to show examples of the intended installation of certain devices

The relatively simple question designers should ask themselves when preparing such documentation is: *Can a reasonably competent installer, familiar with the basic principles of hydronics, install this system as intended and commission it to the desired operating conditions using the documentation I have provided?*

Designers should not assume that those installing the system are familiar with the product selections, or how the overall system is supposed to operate. This is especially true if the design is for anything but a very basic system using the simplest of controls.

From the standpoint of *installers*, documentation should include:

- *Labeling* of all major components in the system, including circulators, valves, heat exchangers, mixing devices, controllers, sensors, etc. Be sure the labeling matches the component abbreviations shown on the piping and electrical schematic. The labeling should also be durable and not subject to damage from water or the temperatures likely to be encountered by the components being labeled.
- A system service log stating the date when the system was commissioned; what all initial control settings are; and what flows, temperatures and pressures were measured at locations where the designer has specified intended values for these parameters. This log should also include a description of the fluid used in the system, and any chemicals added to that fluid. It should be updated to describe any service or adjustment to the system, the exact nature of that work, and the date/time it was performed. The log should be maintained both onsite, in a labeled binder in the mechanical room, and offsite where it can be easily referenced.

It is extremely important that *any* individuals involved with the system record any changes made to any operational settings. Examples would include settings on electrical/electronic controllers; adjustment of mechanical valves for balancing or mixing; adjustments to circulator speeds; or changes to settings within devices having their own embedded controllers, such as boilers, heat pumps, or other heat sources or chillers.

Any changes should be communicated to all those who have access and authority to make changes to settings in the system, including the owner, installer, commissioning agent, designer, or those performing any type of system monitoring. A lead person (typically the system designer) should approve any changes to system settings before they are made, and maintain accurate records of all such changes. A common tool for maintaining such a log would be a spreadsheet file that can easily be emailed to anyone having access to the system.

EXAMPLES OF DOCUMENTATION

There are several parts to a complete documentation package. Each will be introduced and briefly discussed. Later sections will provide additional details on each part.

PIPING SCHEMATIC

Figure 2-2 shows an example of a piping schematic prepared for a system that uses an air-to-water heat pump to provide space heating and partial heating of domestic water.

A piping schematic shows the *relative placement* of the non-commodity devices within a system. *It is not a scaled drawing, nor does it show the exact physical placement of the devices within a mechanical room.*

The installer uses the schematic to ensure proper placement of the devices within the overall system, but still has flexibility on the exact physical placement of these devices to best suit the available space in the mechanical room, and ultimately where the piping circuits need to be routed to reach the heat emitters.

For example, some of the PEX tubing circuits connecting the panel radiators to the manifold station in figure 2-2 may be routed downward from the manifold station rather than upward as shown in the schematic. The manifold station may be mounted at a different elevation compared to where it is shown in the schematic. The expansion tank may not be installed at an elevation below the bottom of the buffer tank, but it will still be connected to the piping entering the lower right side of the tank.

Notice that several major components, such as the circulators, heat exchanger and temperature sensors shown in figure 2-2, have been identified with abbreviations such as P1, P2, S1 and HX1. These abbreviations can be used in other documents, such as an electrical schematic or description of operation. They allow someone to “cross reference” between these different parts of the documentation package.

In many cases, the abbreviations are selected by the designer. For example, a given circulator could have abbreviations such as P1, P-1, C1 or C.1. Designers that work for the same company should standardize abbreviations so that all documents produced use a consistent format.

It is extremely important that the component abbreviations used for devices within the same system be consistent from one document to another, or from one portion of a drawing to another. Thus, if circulator (P1) provides flow to the air-to-water heat pump on the piping schematic, it can be properly wired for this task based on the electrical schematic, and its operation can be properly narrated within the description of operation.

Piping schematics can be drawn by hand or using many different types of software. The latter approach offers many advantages.

Section 3 will discuss how to make piping schematics in greater detail.

ELECTRICAL SCHEMATIC

Another important part of good system documentation is an electrical schematic showing all electrically operated devices within the system, how they are interconnected, and how they are powered. Figure 2-3 is an electrical schematic that corresponds to the piping schematic shown in figure 2-2.

Figure 2-2

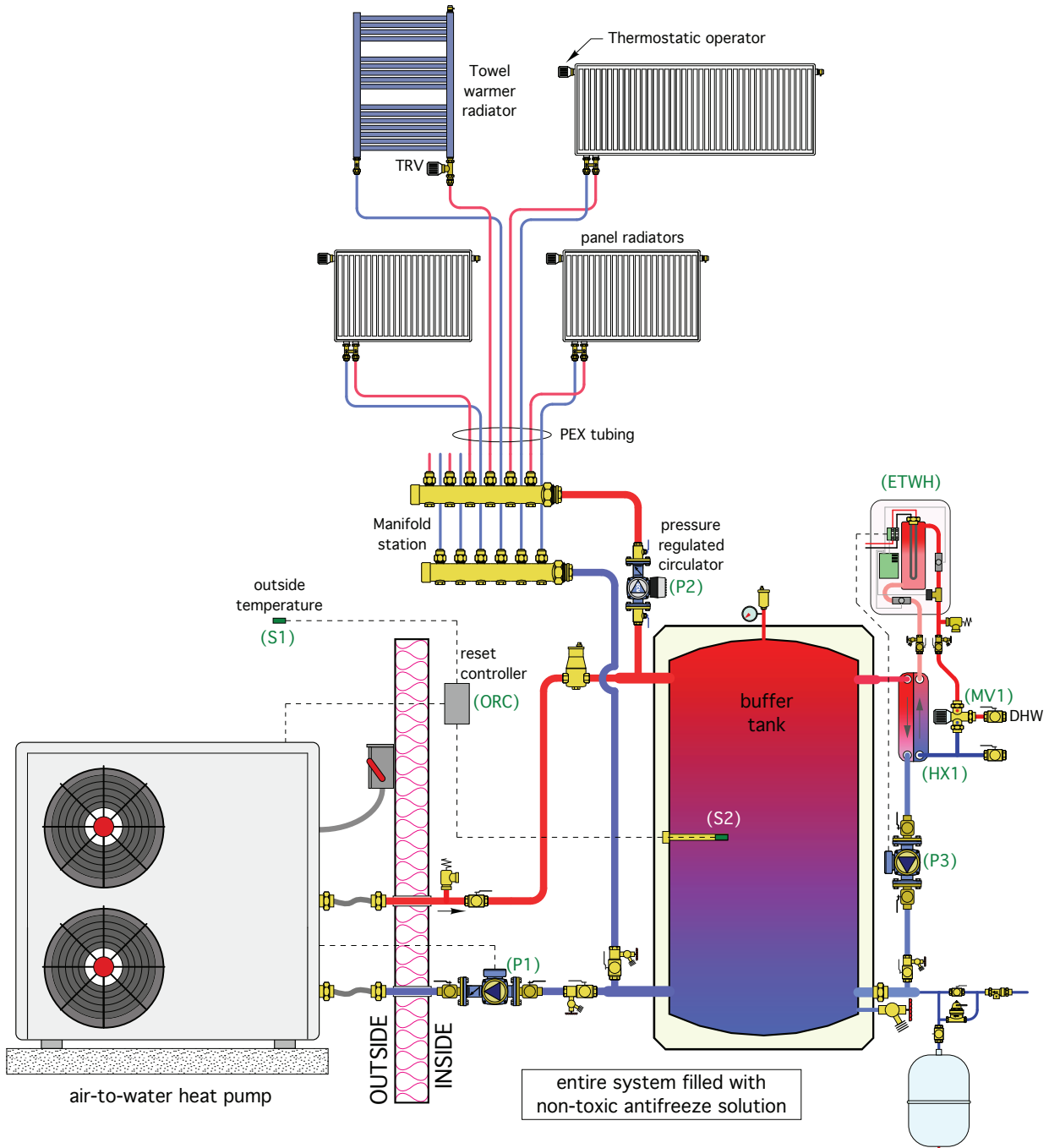

An electrical schematic shows the interconnection of electrically operated devices within the system. It is not a scale drawing, nor does it show the exact physical location of electrical devices when they are installed.

The right-side portion of the electrical schematic in figure 2-3 is drawn as a “ladder diagram.” The vertical lines near the top represent the two conductors required for line voltage: (120 VAC) on the left, and neutral on the right. The main switch (MS) must be closed for 120 VAC voltage to be present below the switch.

Any horizontal “rung” connected across these two vertical lines represents a portion of the electrical system that connects across line voltage. In this system, the two circulators identified as (P2) and (P3) are shown in the line voltage portion of the ladder diagram. The device

symbols to the left of these circulators represent normally open relay contacts. The normally open relay contact within each rung must close to transfer line voltage to its associated circulator and turn it on. When the relay contact is open, no voltage is present at the circulator and it is off.

The lower rung on the line voltage portion of the ladder represents the primary winding of a transformer. This transformer establishes a dividing point in the ladder diagram. All rungs above the transformer, including the transformer’s primary winding, operate at line voltage. All rungs below the transformer, including its secondary winding, operate at lower (a.k.a. “secondary”) voltage. Many HVAC control systems have transformers that produce a secondary voltage of approximately 24 VAC.

The two smaller portions of the drawing, seen at the left, show wiring for a specific make and model of heat pump, and specific wiring for a tankless electric water heater. These two devices are supplied by their own dedicated electrical circuits, and thus not part of the ladder diagram. However, they are part of the overall control system. The relay contacts designated as (RH1-1) and (RH1-2), are wired to specific terminals in the heat pump, and contacts associated with relay coil (RH2) are seen in the ladder diagram. *The labeling is the only indication of the relationship between the coil and contacts of a given relay, and thus is critically important.* The coil and all contacts of a given relay are physically part of the same device, but they are often shown separately in the ladder diagram to keep it graphically simple. A relay coil would have an abbreviation such as (R1), and its associated contacts would have abbreviations such as R1-1, R1-2, R1-3, etc.

The abbreviations for the circulators (P1), (P2) and (P3) in the electrical schematic correspond to the circulators with the same abbreviations in the piping schematic. This is also true for the heat pump (HP) and the electric tankless water heater (ETWH).

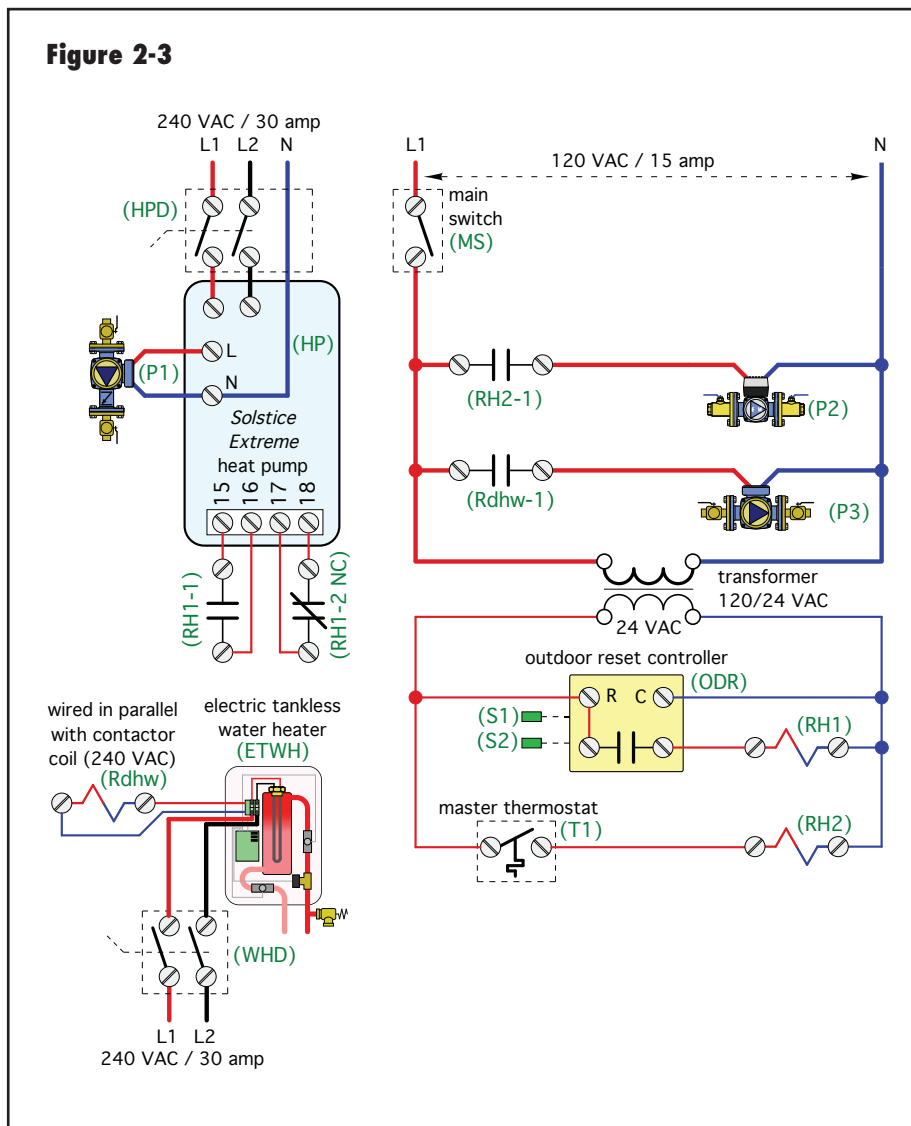

Some components, such as the heat exchanger (HX1) seen in the piping schematic, do not appear in the electrical schematic because they are not electrically operated devices. Still, their abbreviations can be used in another portion of the system documentation called the description of operation.

Section 4 will cover electrical schematics in more detail.

DESCRIPTION OF OPERATION

In addition to piping and electrical schematics, proper system documentation should include a detailed description of operation. Think of this as a narration of the sequence of events that must occur as various electrical components in the system operate to produce a desired result. In general, a description of operation starts with a description of what calls for heating or cooling, and continues to describe what happens in sequence until that call is no longer present. In simple terms, a call for heat occurs, then some control device responds to this call, followed by another control action, followed by another control action, etc., until the call for heat is no longer present.

A detailed description of operation is critically important in communicating the intended operation of the system when all devices are functioning normally. It describes each mode of system operation in detail, and makes frequent reference to identified components within the electrical and piping schematics. Simply put, the description of operation is how the installer learns how the system should respond if it is functioning normally.

When the system is not functioning normally, troubleshooting can be done by sequentially verifying if each intended action in the description of operation is occurring. When one of the actions is not occurring, it's likely the troubleshooter has found at least one system fault and can set about correcting it.

The following text is a description of operation for the system represented by the piping schematic of figure 2-2 and the electrical schematic of figure 2-3.

Heat Pump Operation: *When the main switch (MS) is closed, power is available to the line voltage and low voltage portions of the electrical system. 24 VAC is passed to the outdoor reset controller (ODR), which measures the outdoor air temperature at sensor (S1), and uses this temperature along with its settings to calculate the target water temperature for the mid-height sensor (S2) in the buffer tank. It then compares the calculated*

target temperature to the measured temperature at the tank sensor (S2). If the measured temperature is a few degrees below the target temperature, the contacts in the outdoor reset controller (ORC) close. This passes 24 VAC to relay coil (RH1). Contact (RH1-1) closes and (RH1-2 NC) opens to turn on the air-to-water heat pump in heating mode. Circulator (P1) is turned on by an internal relay in the heat pump.

Space Heating Distribution: *If master thermostat (T1) is calling for heat, 24 VAC passes to the coil of relay (RH2). Contact (RH2-1) closes to turn on the distribution circulator (P2). Circulator (P2) will automatically vary its speed to maintain approximately constant differential pressure across the manifold station serving the panel radiators. The thermostatic valves on each radiator can be used to limit heat output as desired.*

Domestic Water Heating Mode: *Whenever there is a demand for domestic hot water of 0.6 gpm or more, flow switch inside the electric tankless water heater (ETWH) closes. Relay coil (Rdhw) is wired in parallel with the contactor in the electric tankless water heater, and is energized whenever the contactor is on. Relay contact (Rdhw-1) closes to turn on circulator (P3). Heated water from the upper portion of the buffer tank then flows through the primary side of heat exchanger and transfers heat to the cold domestic water flowing through the secondary side of the heat exchanger. When the demand for domestic hot water drops to 0.4 gpm or less, the flow switch in the electric tankless heater opens, turning off relay coil (Rdhw) and circulator (P3). All domestic hot water leaving the system passes through a thermostatic mixing valve (MV1) to limit the water temperature to the distribution system to 115 °F.*

The preferred way to use the piping schematic, electrical schematic and description of operation is to have copies of all three in view at the same time, either on paper or a large monitor. Read one sentence of the description of operation, then find any components referenced in that sentence on both the piping schematic and electrical schematic. Read the next sentence of the description of operation, and again find any referenced components on the piping and electrical schematics. Pause to understand what happens based on each sentence, and always be sure you understand why the action described is necessary to the functioning of the system.

Section 5 will cover descriptions of operation in more detail.

Figure 2-4

Circulator	Function	Make/model	Notes	isolation flanges
P1A	wood boiler bypass	Grundfos UPS 15-58 (speed 2)	with internal flow check	Webstone 1.5"
P1B	wood boiler to thermal storage	Grundfos UPS 15-58 (speed 3)	WITHOUT internal flow check	Webstone 1.5"
P2	injection circulator	Grundfos UPS 15-58 (speed 3)	with internal flow check	Webstone 1"
P3	auxiliary boiler	Grundfos UPS 15-58 (speed 2)	with internal flow check	Webstone 1"
P4	aux boiler to indirect	Grundfos UPS 15-58 (speed 3)	with internal flow check	Webstone 1"
P5	main storage to DHW HX	Grundfos UPS 15-58 (speed 3)	with internal flow check	Webstone 1.25"
P6	panel radiator distribution	Grundfos Alpha	with internal flow check (set for auto adapt)	Webstone 1"
P7	first floor heating	Grundfos UPS 15-58 (speed 3)	with internal flow check	Webstone 3/4"
P8	electric boiler	Grundfos UPS 15-58 (speed 2)	with internal flow check	Webstone 1"

COMPONENT SCHEDULES

The most common way to call out the makes and models of specific components on mechanical system plans is through use of a “schedule.” Examples of hydronic system components for which often include:

- Circulators
- Heat emitters
- Boilers or other heat sources
(in systems with multiple heat sources)
- Heat exchangers
- Control valves
- Balancing valves

A schedule lists the specific make and model of each component. It may also list ancillary information such as pipe size, flange requirements, function, electrical data, dimensions, heat output, flue size, etc.

Figure 2-4 shows an example of a circulator schedule that might appear on the same plan sheet as the piping schematic (allowing for quick references). In some cases, schedules are grouped together on a separate plan sheet.

HEAT EMITTER PLACEMENT

Another important aspect of documenting a hydronic heating system is to show the placement of all heat emitters on one or more scaled floor plans of the building.

When radiant floor heating is used, each tubing circuit should be drawn, measured and labeled on the floor plan. A table should be constructed listing all the tubing circuits by a unique designation and giving the length of each circuit. Figure 2-5 shows an example.

Tubing layout drawings can save many hours of “trial & error” tubing placement during building construction. They can also eliminate errors such as excessive long tubing circuits and floor heating circuits routed under cabinets, refrigerators or freezers. These no-tubing areas are marked in gray in figure 2-5.

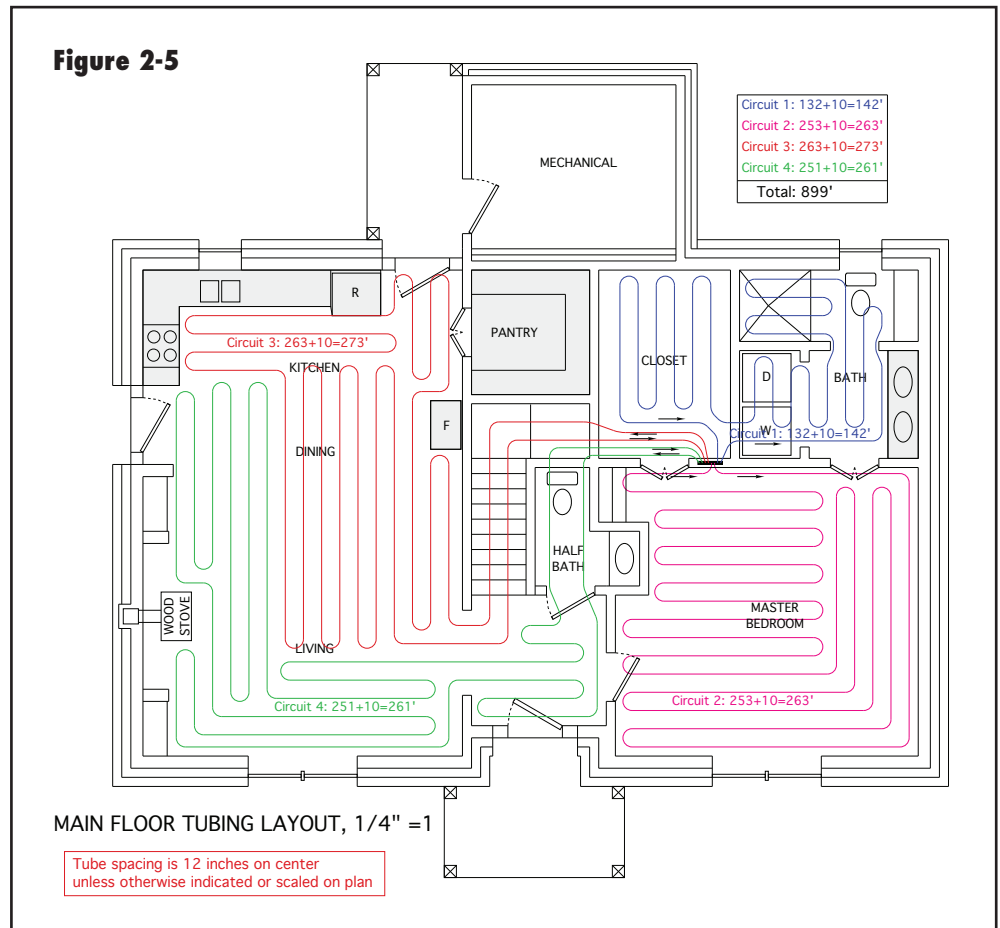

When panel radiators, fin-tube baseboard, fan-coil convectors or other pre-built heat emitters are used, they should be shown on a scale floor plan and identified. The approximate routing path of tubing that supplies each heat emitter can also be shown. This gives the installer a guideline for pipe routing, while

leaving flexibility to make slight adjustments to the routing as needed to avoid unforeseen details such as structural headers, steel beams or other mechanical/plumbing hardware that may already be placed when the hydronic piping is installed. Figure 2-6 shows an example.

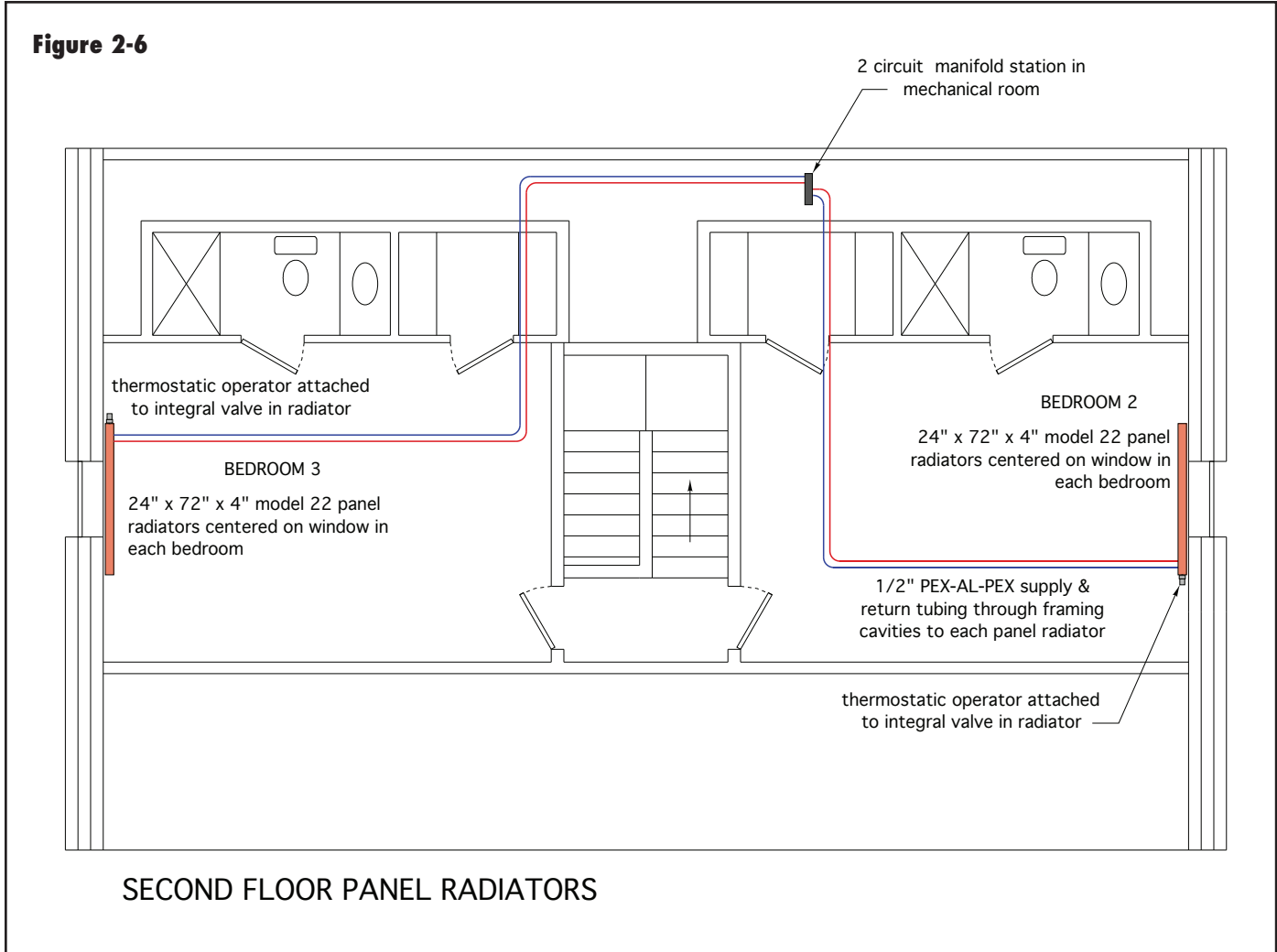

3. TOOLS AVAILABLE FOR DOCUMENTATION

A wide range of tools are available to help designers create the drawings and text necessary for good system documentation. This section will compare them.

The type of documents needed for good system documentation can be classified as:

1. Drawings (e.g., piping and electrical schematics)
2. Text (e.g., description of system operation)
3. Spreadsheets, for use in preparing component schedules

Any word processing software can be used to create the description of operation. Any spreadsheet software can be used to create component schedules. Since most designers and installers are already familiar with word processors and spreadsheets, this section focuses on tools for creating graphical documentation such as piping and electrical schematics.

SKETCHING

For decades, schematics for heating and cooling systems were created by hand, usually on a drafting board or graph paper. Although more time consuming than present-day software-based drawings, these documents accomplished their purpose, even in situations where complex systems were involved.

The most rudimentary form of a piping or electrical schematic is a *sketch*. It allows “spur of the moment” communication of concepts that would otherwise require paragraphs of written text or oral description to explain. A sketch can be made on any suitably sized drawing surface. It might be created during a meeting using markers on a whiteboard, or even on a napkin during a lunch conversation.

Sketching is an important skill. *Anyone involved with the design or installation of heating and cooling systems should have basic competence in making a sketch and adding labels.* The goal is to sufficiently define an idea so that it confirms the feasibility of a particular component arrangement, and so that it’s usable by other people.

The level of detail shown in the sketch should match the level of understanding expected of those who would use the sketch. A sketch prepared by an experienced hydronics professional, and intended only for use by another such individual, may not require the level of detail required if that sketch were to be used by an installer with very little background in hydronics. More detail would

Figure 3-1a

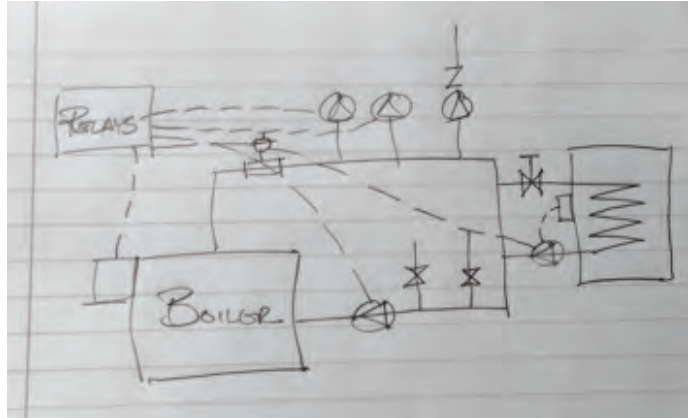
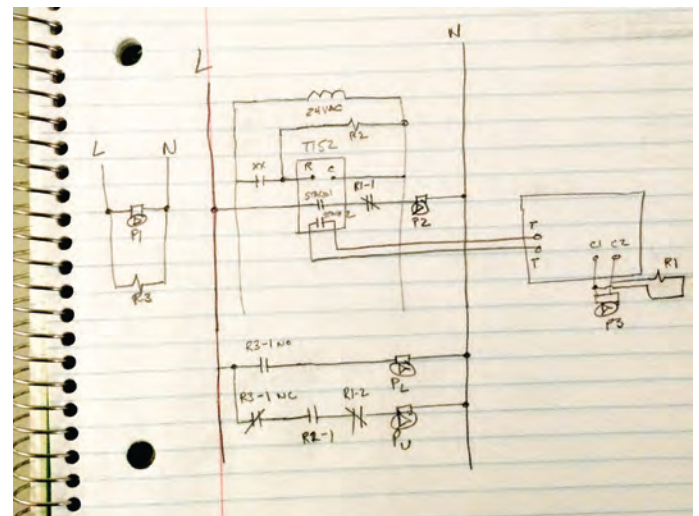

Figure 3-1b



also be required if the sketch is to be passed to another person who will develop a final drawing based on it. The level of detail used is obviously a judgement call on the part of the individual making the sketch. Still, the guiding principal in preparing a sketch is that it’s better to include more detail than less.

Those who learned basic hand drawing in their early years are usually comfortable making a sketch with a pencil on a piece of paper. The expressions “starting with a blank sheet of paper” and “back to the drawing board” derive from the idea that a design begins, or gets refined, based on sketches or drawings prepared by hand on paper.

Today, younger designers may have had little exposure to hand sketching or drawing. Their preferred drawing tools may be a personal computer and tablet computer, both of which have hundreds of available software tools for sketching and drawing. Those with competence with such tools will usually be more productive and

able to create sketches or drawings that simply can't be replicated by hand.

Regardless of the sketching/drawing tool used, designers need to continually practice and refine their ability to quickly create sketches as a starting point for communicating technical ideas.

DRAWINGS

The difference between a drawing and a sketch is that the latter is not a fully detailed representation of the system. It's also not the "cleanest" graphical method for representing the system. A drawing, as defined for the purposes of this discussion, is *constructed using one or more drawing tools*, rather than freehand using a pencil or pen.

The tools for hand-produced drawings include a drafting machine, drafting table, symbol templates, rulers, straightedges, compasses, erasers and other drawing instruments that allow a person to draw more precisely and consistently compared to freehand sketching. Drawing tools also include computer software such as CAD (Computer-Aided Drawing), or special purpose computer graphics software such as that used for flowcharts or printed circuit board design.

Figure 3-2



Source: <http://www.geekpac.org/page/5/>

Although instrument-assisted manual drawing has been used for centuries, it has several limitations:

- If needed on a regular basis, manual drafting requires several hundreds of dollars in equipment and supplies. It also requires skill, patience, good eyesight and good lighting.

- It requires access to some means of reproducing the original drawing into "blue line" prints that can be physically mailed to those involved in the project.

- Errors or changes to the design require erasing and redrawing, which can be time consuming and messy. Major changes often require a completely new drawing.

- The use of color in the drawing is often limited based on the reproduction methods used.

- Even the best manual drafters cannot match the production speed of experienced CAD operators.

- Drawing storage can require large flat files such as those seen in the background of figure 3-2.

Figure 3-3 shows an example of how manual drawing was used to create radiant panel circuits, primarily those used in floors, using templates with offset semi-circulator return bend cutouts. What seems like an antiquated method by today's standards was common practice only 20+ years ago.

Figure 3-3

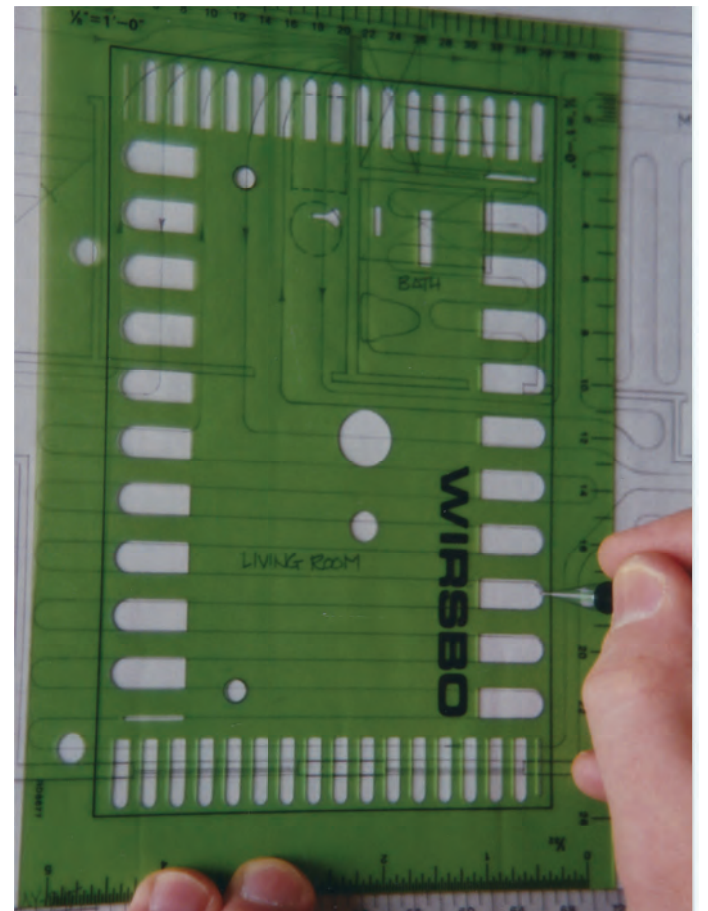

CAD SOFTWARE

The time from 1980 through the end of the 20th century was one of transition for many professionals who produced drawings on a daily basis. The transition was away from traditional manual drafting to computer-based drawing. Computer-aided drafting (CAD) quickly became the standard for 2-dimensional drawing in most engineering and architectural offices. It offered significantly increased productivity, instant deletion of unwanted drawing details, ability to make multiple iterations of a basic concept to refine the design (without constantly having to erase objects, or redraw the same details over and over), ease of passing drawings between multiple people, and digital storage (rather than paper-based storage).

When it was first introduced, CAD software was expensive and often unaffordable by smaller firms or those who only needed to create occasional drawings. Many hours of training were required to become proficient with early-generation CAD software. Top-end computers with specialized graphic cards, math coprocessors, lots of memory and large hard drives were also required for early-generation CAD software to operate to its full potential. Once the drawing was created, it still needed to be transferred to paper using expensive peripherals such as multiple pen plotters. At the time, very few small businesses, such as heating contractors or small engineering firms, could afford the software, hardware and training necessary to implement CAD-based drawing into their workflow.

That situation has changed drastically over the last 10 to 15 years. Today there are several full-featured CAD software packages that are inexpensive (under \$200), or even *freely available* as Internet downloads. Some examples include:

SOFTWARE NAME	WEBSITE
Draftsight 2016	http://www.draftsight2016.com
LibreCAD	http://librecad.org/cms/home.html
SketchUp	http://www.sketchup.com
TurboCAD Deluxe 2016	www.turbocad.com

Low-cost CAD software is also offered as “browser-based” or “cloud-based.” Rather than purchasing the software, installing it and running it entirely on a standalone computer, the user purchases “access” to

use the software on one or more computers, and for a specific time (typically a month or a year). The software is accessed through a web browser such as Safari®, Firefox®, or Google Chrome®. The user interacts with the software essentially the same way as if it were running on their personal computer. This approach offers the advantages of broad compatibility across different operating systems, such as Windows®, MAC OS, and Linux. It also offers easy software updates, remote access to drawing files on a variety of Internet-enabled devices, and cloud-based backup of drawing files.

Examples of browser-based drawing software include:

SOFTWARE NAME	WEBSITE
SmartDraw Cloud	https://www.smartdraw.com
HydroSketch	www.hydraulicpros.com

Figure 3-4 shows an example of a piping schematic created with HydroSketch.

Figure 3-4

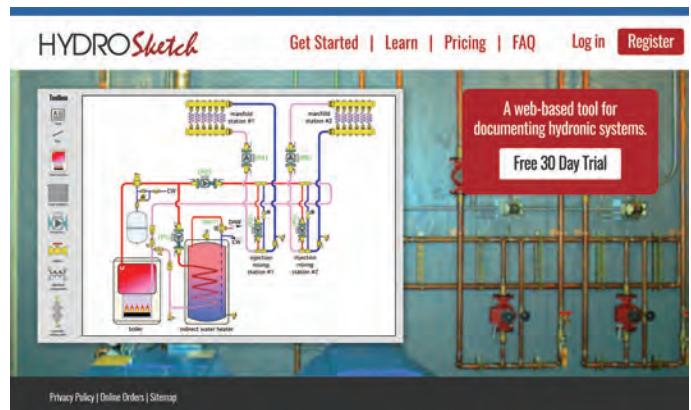

There is also software available for specialized design and drawing needs associated with hydronic systems. One example is software for placing radiant floor tubing circuits within a scaled floor plan. Another would be software for inputting architectural drawings prepared in a CAD system for the purpose of preparing heating load estimates or demonstrating compliance with specific energy codes.

Figure 3-5

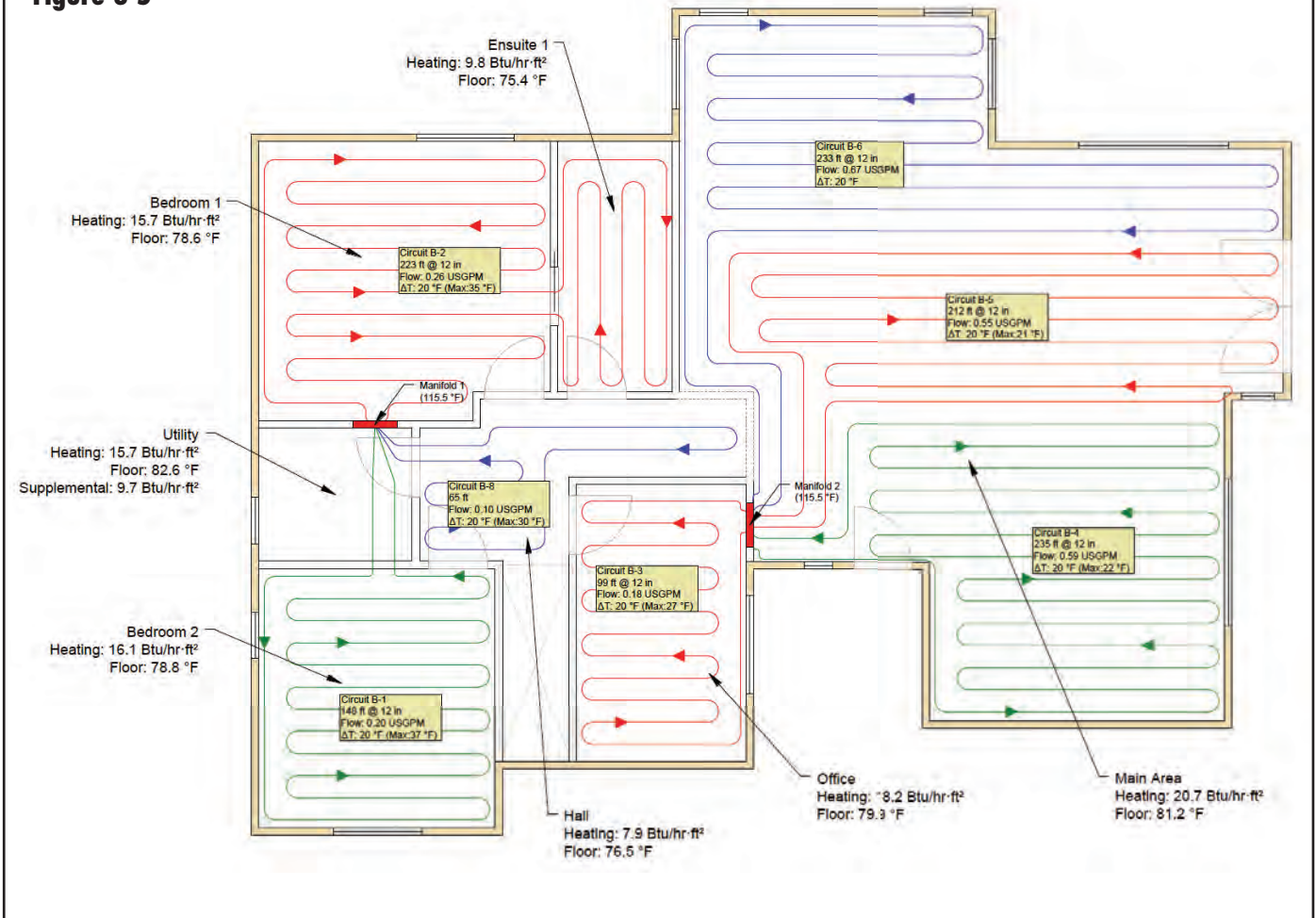

Courtesy of Avenir Software

Figure 3-5 shows an example of LoopCAD® software that is used for automatically creating circuit layout drawings for hydronic radiant panel systems.

VECTOR-BASED vs. PIXEL-BASED DRAWING SOFTWARE

There are hundreds of computer graphic software packages available. They can be loosely categorized as either vector-based or pixel-based.

Vector-based software creates drawing objects that are mathematically defined and maintained within the software. For example, a simple line segment is a drawing object having a precise beginning and end coordinate. The precise mathematical definition of this line object is used by the computer to draw it on the monitor based on the current zoom level being viewed. If the zoom level is changed, the mathematical description of the line object allows it to be instantly redrawn on the

monitor at the new zoom level, but always retaining its exact mathematical definition. When the view shown on the monitor running a vector-based drawing program is zoomed in, the object, or portions of the object being viewed, retains a crisp and precise appearance. Lines joined at their end point remain precisely joined at those points regardless of the level of zoom. Nearly all CAD software uses vector-based drawing.

Because the objects created in vector-based software are mathematically defined, the software can quickly determine geometric properties such as the center of a circle or rectangle, or, for example, find a point that is exactly 1/5 of the length of a line from its endpoint. The precise geometry used in vector-based drawing allows operations such as precisely rotating an object, drawing a line at a precise angle or instantly determining the area of a complex shape. Such operations, although often hidden beneath the surface of the software's user interface, allow vector-based drawing software to provide precision far

Figure 3-6a



Figure 3-6b



beyond what the human eye can see, or what the best manual drafter can create.

Pixel-based drawing software creates pixel images. Such images are a collection of points (pixels) that make up a grid. That grid may be several thousand pixels wide, and thousands of pixels high. Each pixel is very small. In some software, there are over 1200 pixels used to represent each inch of width and each inch of height of the object. Within the grid, each pixel has a color. When viewed on a monitor, the overall combination of colored pixels appears as an object or a photo. The unaided eye of a person with 20/20 or better vision, can only resolve images to approximately 900 pixels per inch when viewed at a distance of 12 inches.

Although pixel-based graphics are well applied for certain types of images, such as those created by a digital camera, they have limitations

when applied to drawings. The primary limitation is that pixel-based graphics appear to become “grainy” when the view is zoomed in. That’s because there are only so many pixels to represent the image. Zooming into a view reduces the number of visible pixels, and thus what might appear to be smooth contours or precisely shaped objects at normal resolution become less precise.

A small triangle, drawn using pixel-based software, is shown in figure 3-6a. It appears to have straight, smooth lines. However, when the view is zoomed in 500%, as shown in figure 3-6b, the same triangle appears to have lines with rough/grainy edges.

The types of drawings needed for documenting hydronic systems, and the methods used to efficiently produce them are better suited to vector-based drawing software.

BUILDING INFORMATION MODELING (BIM)

BIM is a set of software processes that helps organize a wide variety of systems within a 3-dimensional virtual model of a building. Examples include systems for heating, cooling, ventilation, fire protection, plumbing, electrical, communications, freight movement and human transport. These systems can be coordinated with the structural elements of the building to determine any interference, and then perform the necessary changes to avoid that interference. Multiple design disciplines such as architects, structural engineers, mechanical system engineers and electrical system engineers can work in a coordinated (sometimes simultaneous) manor, which expedites planning and reduces errors during construction.

Figure 3-7

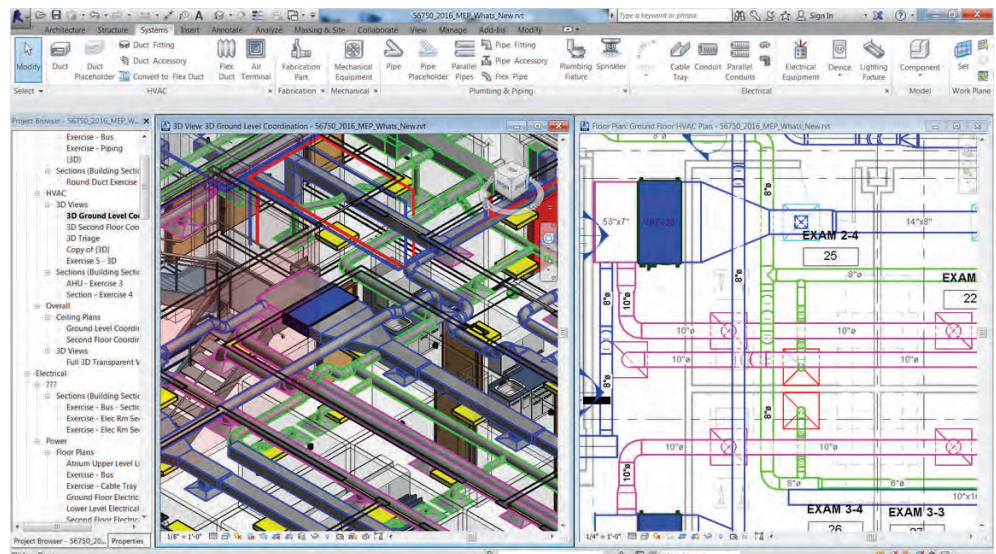

Source: Autodesk

Figure 3-8

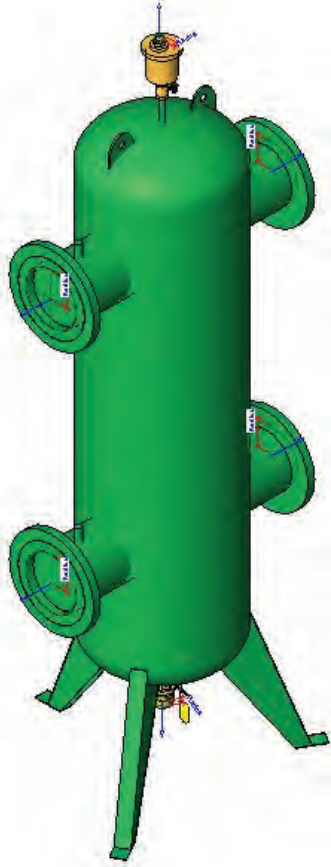

Many manufacturers of equipment for building systems, including Caleffi North America, offer BIM files for of their products. These files can be downloaded into BIM software, such as the Autodesk Revit® package, and then placed within the mechanical or plumbing systems in the building. An example of a 3-dimensional BIM model of a Caleffi hydraulic separator is shown in figure 3-8.

Some BIM systems also use a database for each component that contains specific information, such as dimensions, flow characteristics, weight, etc., as shown in figure 3-9. In some cases, portions of systems can be simulated to verify adequate performance.

CALEFFI SYSTEM SCHEMATIC LIBRARY

In 2017, Caleffi North America began offering a library of hydronic system drawings that is freely accessible at www.caleffi.com. This can be accessed by scanning the QR code in figure 3-10a.

Figure 3-10a



Each system shown in the library is represented by a piping schematic, an list of materials and an accompanying description of operation.

Figure 3-10b shows an example of one piping schematic from the library.

Figure 3-9

Parameter	Value	Formula
Constraints		
Vent Shut Off Valve Length	0' 2 19/128"	=
Vent Height	0' 6 1/4"	=
Vent Connection Radius	3/8"	=Vent Connection NPT / 2
Vent Connection Length	0' 3 15/16"	=
System Connection Radius	6"	=System Connection / 2
Primary Outlet Connection to Primary Inlet Connection	3' 11 1/4"	=
Primary Inlet Connection to Vent Bottom	2' 1 25/32"	=Primary Inlet Connection to Vent Connection
Primary Inlet Connection to Vent Connection	1' 11 81/128"	=
Pipe Thermometer Connection Radius	1/2"	=
Pipe Thermometer Connection Length	0' 1 147/256"	=
Pipe Outside Radius	6 1/8"	=System Connection Radius + 0' 0 1/8"
Pipe Length	3' 9 1/8"	=(Connection to Connection - (Flange Thickness))
Lift Ring Width	0' 5 249/256"	=Lift Ring Height * 0.7
Lift Ring Thickness	0' 0 3/4"	=If(System Connection < 0' 10", 0' 0 1/4")
Lift Ring Inside Radius	1"	=If(System Connection < 0' 10", 0' 0 1/2")
Lift Ring Height	0' 8 17/32"	=Body Top Height
Flange Thickness	0' 1 1/4"	=
Flange Outside Radius	9 1/2"	=Flange Outside Diameter / 2
Flange Outside Diameter	19"	=
Flange Lip Thickness	0' 0 1/16"	=
Flange Lip Outside Radius	7 1/2"	=Flange Lip Outside Diameter / 2
Construction		
Leg Quantity	3	=
Materials and Finishes		
Vent Material	Metal - Caleffi - Brass	=
Seal Material	Rubber - Caleffi - EPDM	=
Air Separator Material	Paint - Caleffi - Green	=
Plumbing		
Vent Connection NPT	3/4"	=
System Connection	1 1/2"	=
Pipe Thermometer Connection NPT	1/2"	=
Fluid Type (default)		=
Drain Connection NPT	2"	=
Connection Type	ANSI B16.5 Class 150 RF	=
Body Thermometer Connection NPT	3/4"	=
Mechanical		
Minimum Operating Temperature	32.00 °F	=
Maximum Operating Temperature	270.00 °F	=
Mechanical - Flow		
Secondary Flow Rate (default)	0.000 GPM	=
Primary Flow Rate (default)	0.000 GPM	=

Figure 3-10b

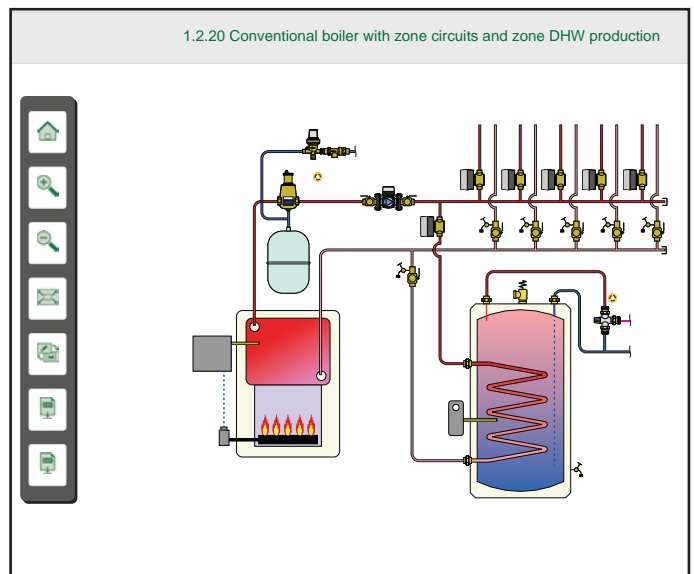

Clicking on the same circular icons adjacent to the Caleffi components brings up product specifications.

Figure 3-11

A3 - Single master thermostat, panel radiators with TRVs, variable speed pump

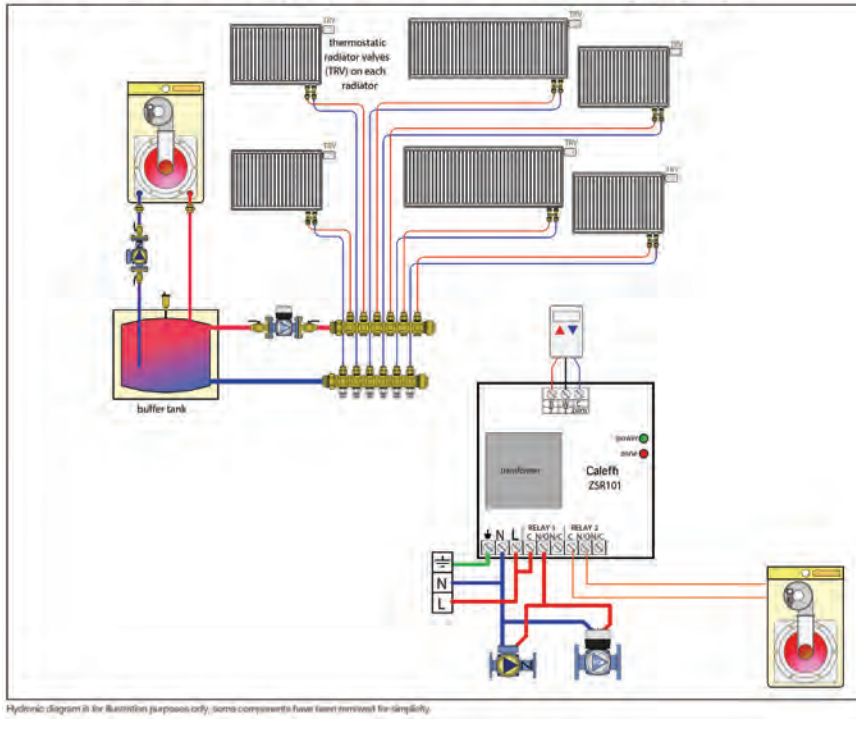

These drawings are offered as *guidelines* for installers. They show what is considered good practice for application of Caleffi hardware, as well as other components. However, it is impossible to know the exact circumstances in which these drawings might be applied, or the specific code requirements at the location where a system based on these drawing may be installed. Those using these drawings must determine any specific requirements related to a given installation, or the code requirements at the installation site, and make any necessary modifications to the system configurations shown in these drawings.

The drawings in the Caleffi Schematic Library can be freely downloaded as PDF files. If these files are opened using software that allows the import of PDF files.

CALEFFI WIRING GUIDE

Many common hydronic systems can be fully managed using the built-in control logic of a multi-zone relay center. Caleffi offers several multi-zone relay center products for zoning with valves as well as circulators. To assist installers with using these products, Caleffi has created an online publication entitled “Z-one Relay Wiring Guide.” This free publication is a PDF file, which can be viewed by scanning QR code below.



The Z-one Relay Wiring Guide presents several common hydronic heating system configurations that require a multi-zone

relay center. Drawings are presented in the form of a piping schematic, associated wiring schematic and a sequence of operation. Figure 3-11 shows an example of a piping and wiring diagram from the Z-one Relay Wiring Guide for a simple hydronic heating system.

Figure 3-12 shows the corresponding sequence of operation and description of terminals.

Figure 3-12

Description of terminals

- ⊕ = Ground
- N = Neutral (Common leg of 120 VAC)
- L = Line (live leg of 120 VAC)
- C = Common terminal
- NO = Normally Open terminal
- NC = Normally Closed terminal

Note: There is a factory installed jumper between the 120 VAC line (L) and the common terminal of relay #1 (C).

Thermostat terminals

- R = 24 VAC
- W = Heat call
- C = Common of 24 VAC



Sequence of Operation / Settings

- A demand occurs from the thermostat closing R to W on the ZSR101 control. The “ZONE” LED illuminates.
- The ZSR101 control will power relay #1 and #2 closing C to NO.
- The NO terminal of relay #1 will send out 120 VAC to your pumps. Relay #2 provides a dry contact closure to signal the boiler of a demand.
- **NOTE:** Relay #1 can be used as a dry contact as well by removing the factory installed jumper between L and C.
- When the thermostat demand is satisfied R to W will open and the “ZONE” LED will turn off.
- The control will remove power from relays #1 and #2 opening C to NO. This will drop 120 VAC to your pumps and terminate the demand to your boiler.
- **NOTE:** In this application, the single thermostat will be set to a slightly higher temperature than the desired room temperatures. The room temperatures will then be controlled by each individual thermostatic radiator valve by adjusting the flow through the radiator making this a fitting application for a variable speed (ECM) pump (between the buffer tank and radiators). When the temperature drops below the set point of the thermostat the boiler will maintain the buffer tank at its target temperature. Ideally, the boiler will operate on an outdoor reset curve to maximize efficiency and use a system temperature sensor located in the upper portion of the buffer tank.

4. CREATING PIPING SCHEMATICS

Piping schematics are used to show the *relative* placement of components within an overall hydronic system. A typical hydronic system schematic would show all heat sources and all heat emitters in the system. It would also show all non-commodity components, such as circulators, air separators, dirt separators, buffer tanks, heat exchangers, expansion tanks, make-up water assemblies, mixing valves, zone valves, flow meters and temperature sensors.

Piping schematics are useful for design, installation and servicing of hydronic systems.

Designers can quickly conceptualize a system, and perhaps create multiple variations of the system using piping schematics. The arrangement of components within a piping schematic defines one or more piping circuits in the system. Designers may then analyze the required thermal and hydraulic performance of these circuits, and select hardware that allows each circuit, as well as the overall system, to perform as required.

Installers use piping schematics to guide them during installation. Although the schematic does not show the exact placement of a component within a mechanical room, it does show how they must be placed relative to each other. Experienced installers develop skill in placing the components in a neat and efficient manner, while keeping them in the proper relative positions shown on the schematic.

Piping schematics are also very helpful in troubleshooting systems. They provide a fast way to communicate the overall system layout, especially for those not already familiar with the system, and without having to trace down numerous piping circuits to determine the extent of the system.

SCHEMATIC SYMBOLS

Piping schematics are drawn by placing symbols that represent various components onto a drawing “canvas” (e.g., paper or the drawing space seen on the display while using CAD software).

Since CAD-based drawing represents the state-of-the-art approach to schematic drawing, the discussion that follows will assume that CAD-based drawing is being used.

Whenever possible, the piping symbols used in schematics should be drawn *before work begins on a schematic*.

These symbols can be organized into a symbol legend, such as shown in figure 4-1.

Having the symbols ready to go greatly speeds the drawing process. It allows designers to focus on the system, rather than be distracted when the need for a new component symbol arises.

Those using CAD software to create schematics can either create their own symbol library using that software, or purchase a library of pre-drawn symbols in a file format that can be imported by their CAD software.

An advantage of creating one’s own schematic symbol library is that the component symbols can look exactly the way the person creating them desires. The drawing process can also take full advantage of the capabilities of the CAD system that will eventually be used to manipulate these symbols into a complete piping schematic. Such capabilities include options for colors, gradients, pre-drawn pipe threads or fastener details, choices for line width and patterns, text options and more. Once they are created, the symbols can be duplicated as many times as needed. This creates a distinctive and consistent appearance between schematics coming from the same designer, or the same firm. The schematic symbol library can also be expanded over time as new devices become available.

The main disadvantage of creating a symbol library is that it requires time and effort. Many hours of drawing time are needed to create an extensive symbol library in which the symbols are well detailed, such as those shown in figure 4-1. If the person making the schematic is not skilled in using the CAD software, or if the projects for which the schematics are needed require immediate results, commercially available symbol libraries can be purchased.

The degree of detail shown on a schematic symbol can vary. The symbol could be a highly simplified representation of the component and look completely generic, or it could have close resemblance to a specific product. Figure 4-2 shows some examples of schematic symbols representing a micro-bubble air separator.

The very simple/generic symbol on the far left is usable, but lacks visual interest. Without already knowing that it was drawn to represent an air separator, or being familiar with the general shape of such a device, it is not evident what this symbol represents (e.g., maybe

Figure 4-1

GENERIC COMPONENTS

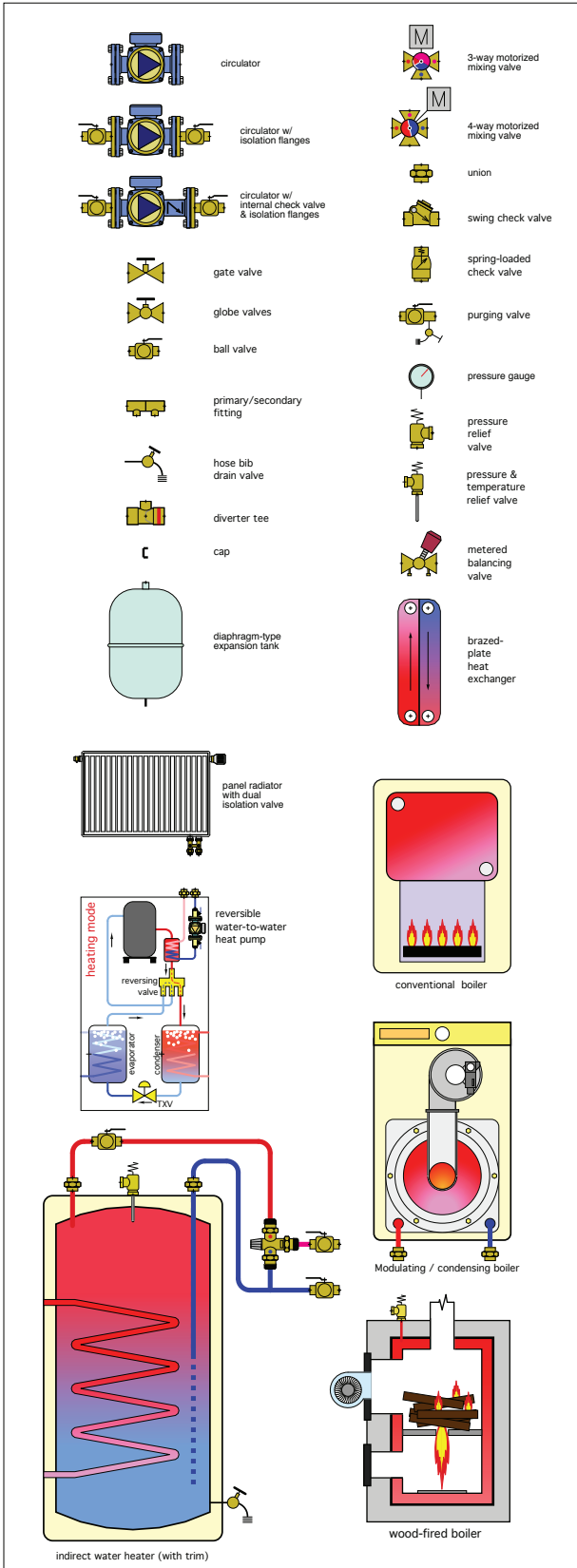

CALEFFI COMPONENTS

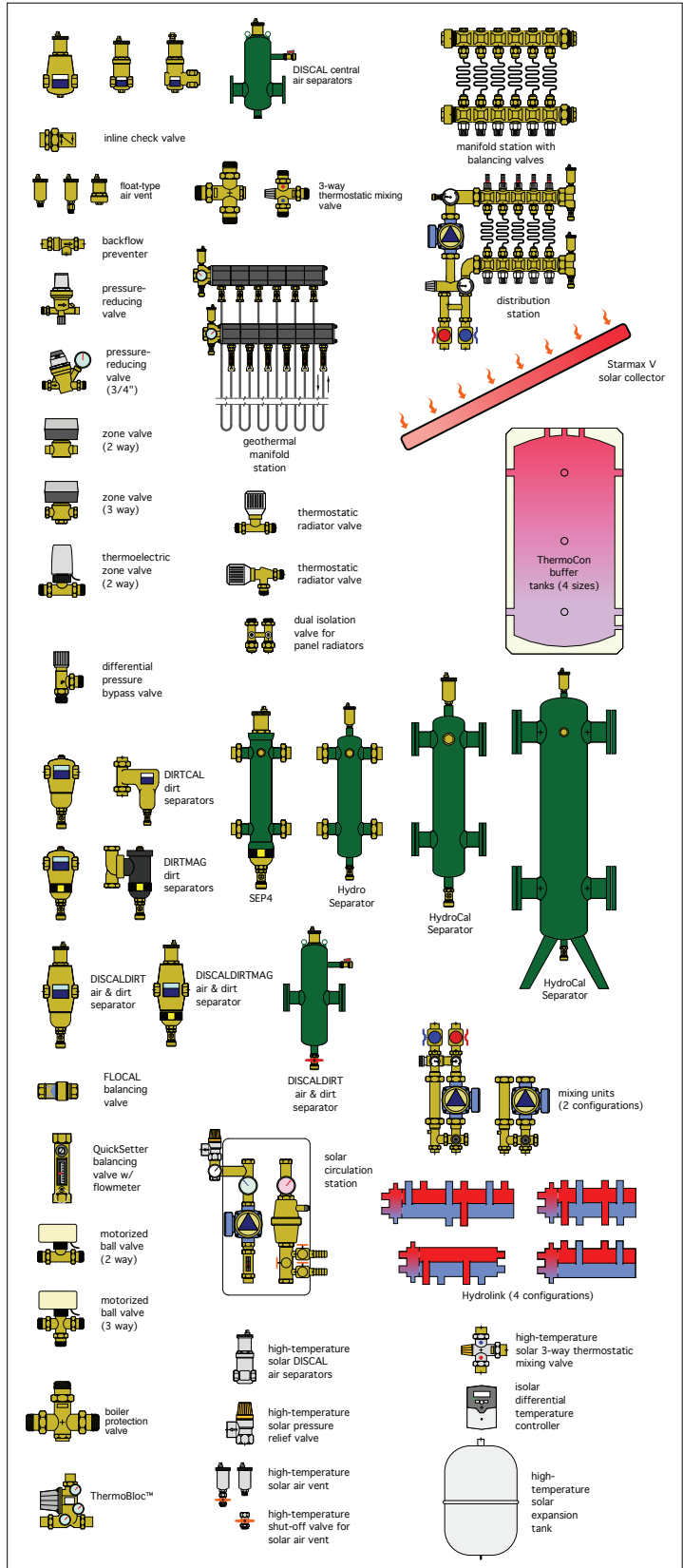
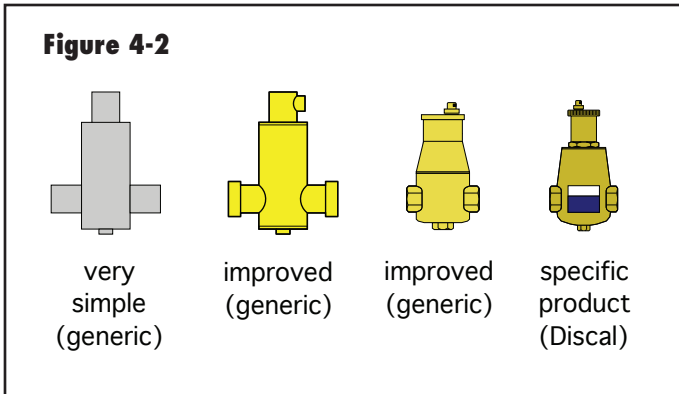

Figure 4-2



When drawing schematic symbols, keep in mind that they are usually shown as small objects, especially when an entire system schematic is printed to standard 8.5 x 11-inch paper. An excessively high level of detail on the symbol, especially for small components, may be lost when the symbols are viewed on screen, or printed on devices that may not have the high resolution to show all details.

An appropriate level of detail can be established by drawing a given symbol with several different levels of detail, then viewing each of them on a typical display, and printing them to a typical laser or inkjet printer. Details that essentially disappear on screen at normal viewing size, or become muddled on printed output, are of little value and can be eliminated.

it represents a circulator, a flow meter, or a chemical feeder, etc.). A person that doesn't know what the symbol represents would have to determine what it is using a symbol legend, which may or may not be included with the schematic drawing of the system.

The two symbols labeled as "improved (generic)" add color and more detail. These both add visual interest that help hold the attention of the person looking at the schematic. The shape of these symbols makes it more likely that they will be recognized as air separators, at least by hydronic professionals. Their color suggests that they are probably made of brass. However, both symbols remain generic. Neither represents a specific make or model of an air separator.

It's very important to identify the points on the symbol where lines (representing piping) will connect. Some CAD software allows the user to place a specific "point" object at the exact location where a line would attach to the symbol. In some software, the point object is designed to show on screen, but not show on printed output. This is helpful because a line that is being drawn to within a few pixels' distance of the point can "snap" precisely to it. This helps preserve the precise geometry that a CAD system is capable of, rather than trying to align the line to the symbol by eye based on how it appears on the monitor.

The schematic symbol at the far right is drawn with detailing and color to resemble a Discal air separator from Caleffi. It includes additional detail, such as the label.

Schematic symbols for components should also be drawn in approximate proportion to their physical size. For example, an air separator for a 1.25" pipe should not be the same size as a typical cast iron boiler. The symbol

Figure 4-3

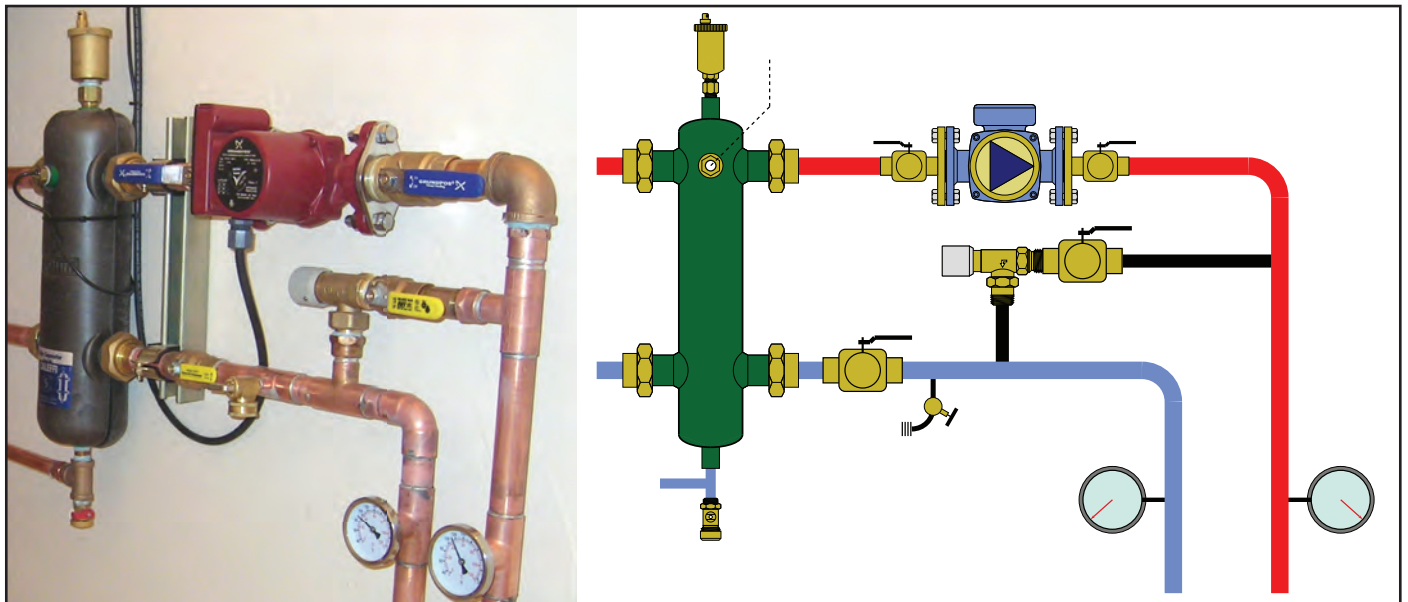

for a thermal storage tank would be significantly larger than the symbol for a 2" ball valve.

Figure 4-3 shows a photo of some hydronic components assembled as part of a system. It also shows a schematic representation of these components. Note that the size of the schematic symbols is approximately in proportion to the size of the actual components. This lends clarity to the schematic.

DRAWING TECHNIQUES

Once a schematic symbol legend is created, it can be used to make a piping schematic. The exact process used varies from one CAD system to another. Some CAD systems have a library feature where each symbol can be selected from a scrolling list or a floating symbol palette by name, or by clicking on an icon resembling that symbol. In other CAD systems, the person making the schematic may choose to bring the entire symbol legend, such as shown in figure 4-1, into the drawing space and select symbols from that grouping as needed. In this case, it's best to click on the component symbol to select it, *duplicate that symbol*, and drag the duplicate to where it's needed in the drawing. This leaves the symbol legend intact. Any symbol in the legend can be duplicated as many times as necessary.

As the number of schematics drawn by an individual or firm increases, it is common practice to select a completed piping schematic that represents a subsystem similar to the one to be documented, open that drawing, and use or duplicate the component symbols already in that drawing. This saves time in that common details, examples of which are shown in figure 4-4, don't have to be redrawn.

Most CAD systems also have the ability to "group" multiple drawing objects together. Think of grouping as the equivalent of "digital glue." The person using the CAD software can individually select objects to be grouped, often by holding the shift key and clicking on the objects, or they may choose to draw a selection rectangle around several adjacent objects. In either case, once the objects to be grouped are selected, the group command

binds them together as if they were a single object. That new object can then be moved, rotated, duplicated or scaled like any other drawing object. If the grouped object needs to be modified, it can be "ungrouped" using a different command in the CAD software. Grouping and ungrouping is a very powerful technique for expediting schematic drawings, which are characterized by repetitive use of symbols.

Figure 4-4

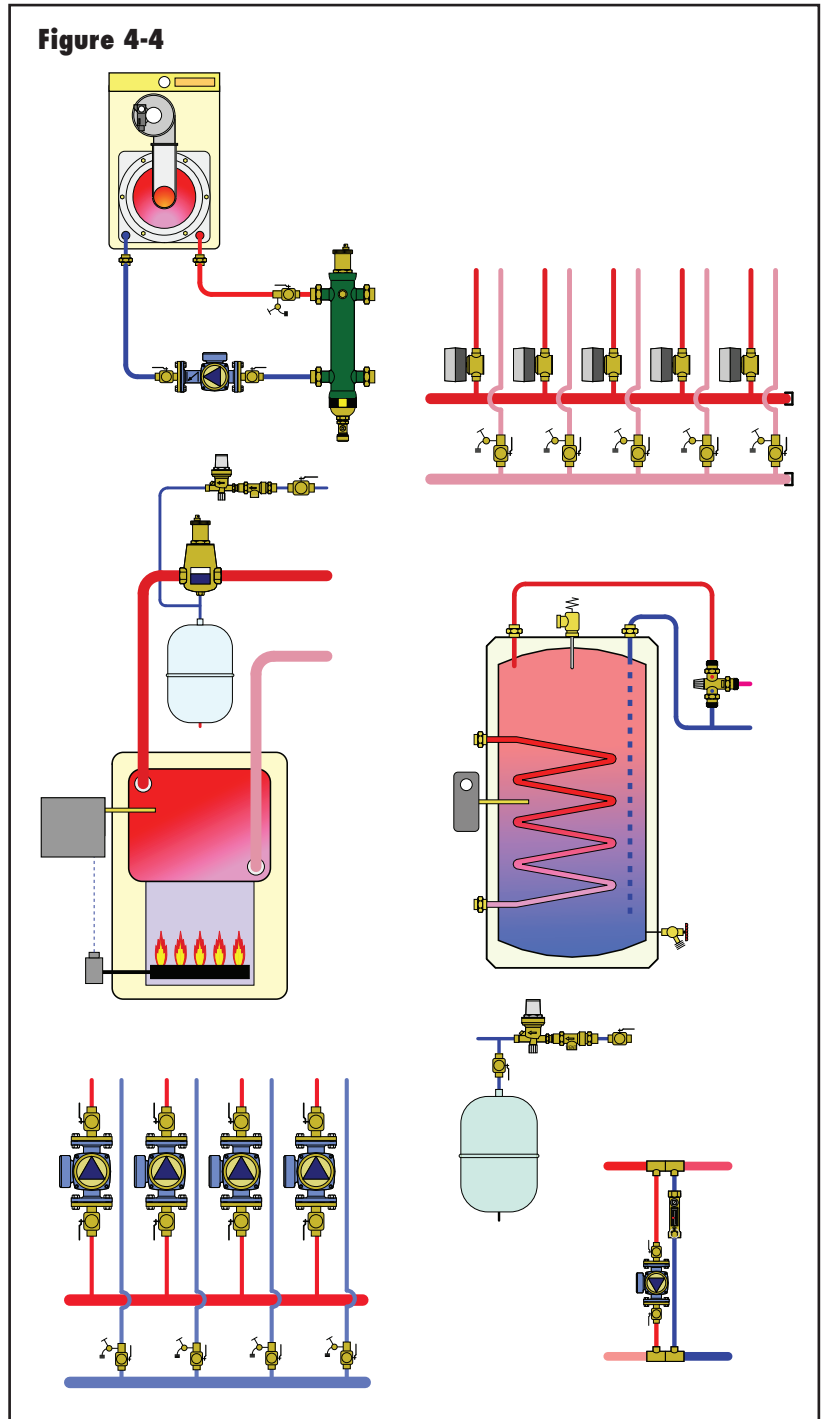
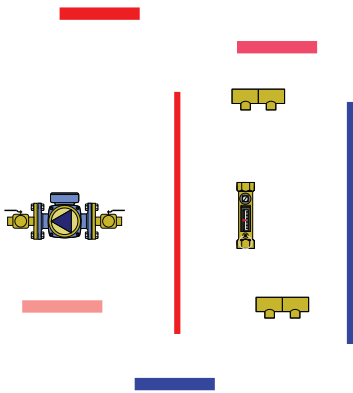
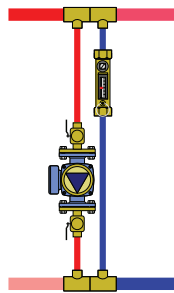

Figure 4-5

1. Gather the needed objects



2. assemble them into the desired detail.



3. Select all the objects, and use the GROUP command.

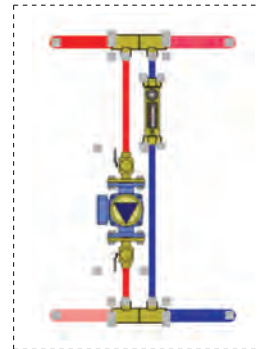

4. duplicate, move, rotate, or scale the grouped object as needed.

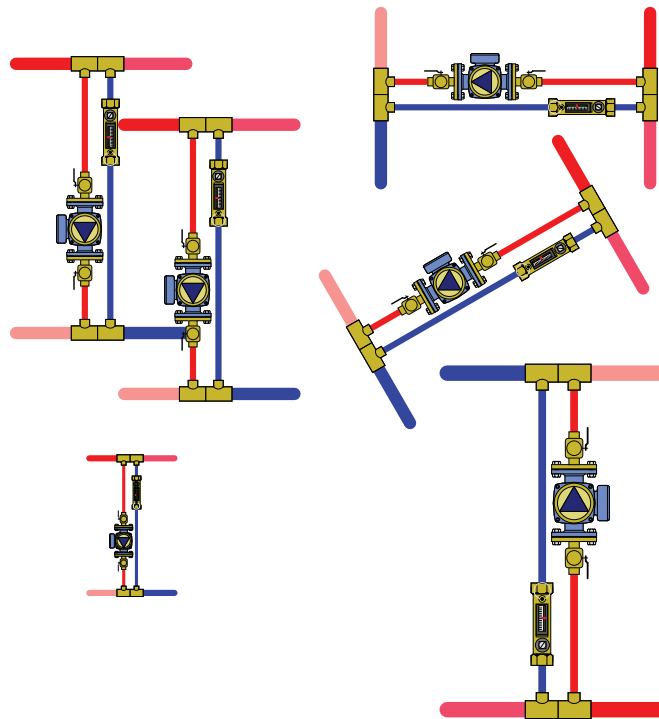

There are many ways to assemble component symbols to create a complete piping schematic. Opinions vary on the “best” approach, which in many cases is highly dependent on the software being used.

One method is to “build” the schematic similar to how the actual components would be assembled. Start with

a major component such as a heat source, attach one or more line segments to the outlet connection that would represent piping, add another component such as an air separator, add another line segment representing more piping, and so forth. While this method is somewhat intuitive, it isn’t necessarily the most productive approach, because the line segments are “broken” at

Figure 4-6

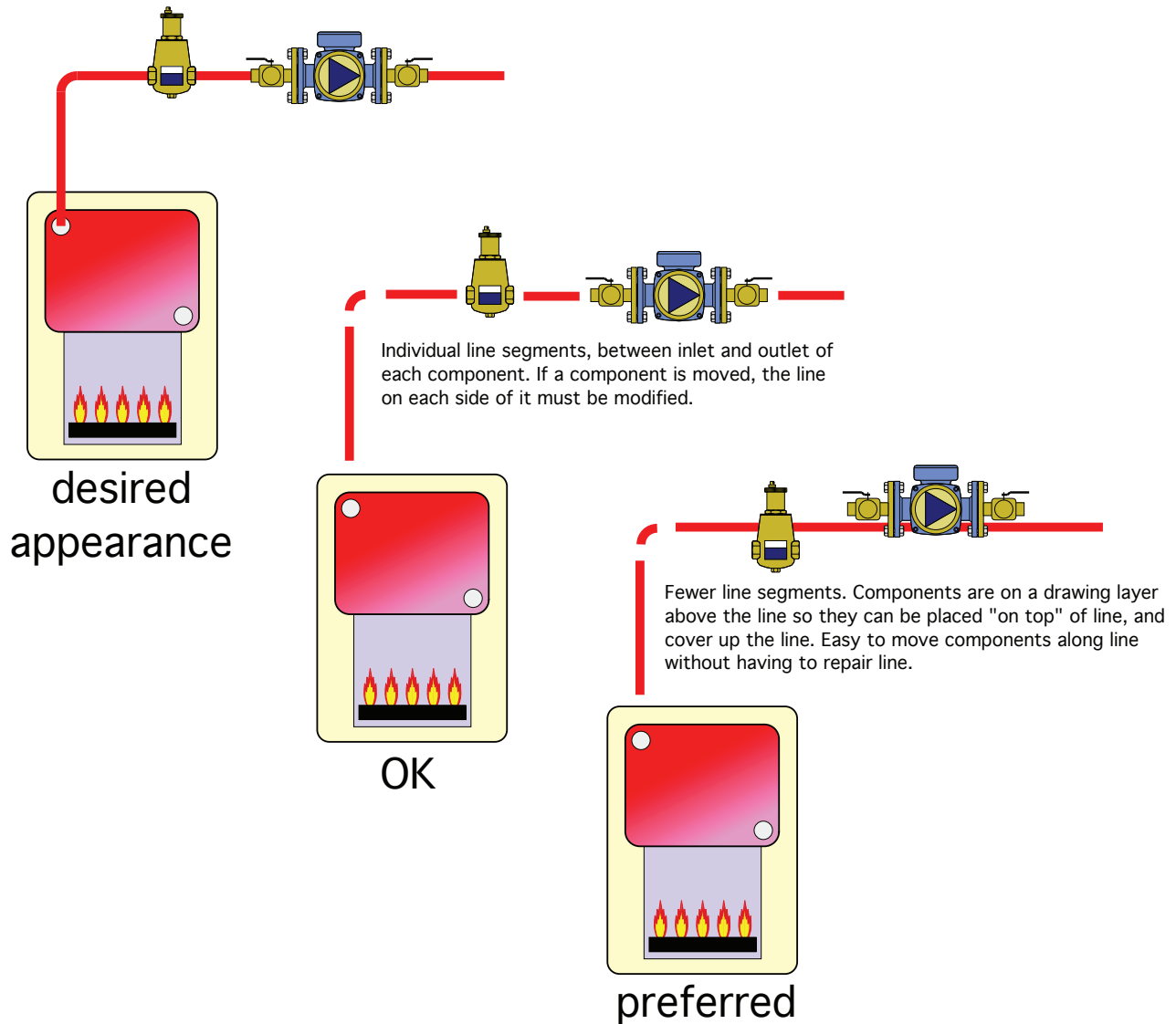

each component. If a component has to be moved, even slightly, the lines connected to it also have to be modified to provide a visually unbroken path.

A preferred approach is to use a feature found in most CAD software called "layers." Think of a layer as the digital equivalent of a thin, transparent sheet having the overall size of the drawing. A drawing can have many layers, perhaps over 100 if needed. These layers can be "stacked" on top of each other, and their stacking order easily changed.

Assume an object, such as a line segment, is drawn on layer 1. Then another object, such as a circulator symbol

is drawn or placed on layer 2. If layer 2 is selected to be on top of layer 1, the circulator symbol on layer 2 will cover up the portion of the line segment on layer 1, which it overlaps. The concept is similar to placing a sticker on a sheet of paper. The sticker covers up the paper beneath it. If the sticker is moved, the area of paper that was covered becomes visible.

Schematic symbols with a non-transparent (100% opacity) color, and placed on a layer above the lines, will simply mask over the portion of the line under them. This allows the symbol to be easily moved along the line, if necessary, without having to later repair any gap in the line. These two methods are compared in figure 4-6.

Whenever possible, piping schematics should be drawn from left to right, based on the flow of heat through the system. For example, if a boiler is the heat source, its preferred location is on the left side of the schematic. Other components through which heat passes would then be placed to the right of the boiler. The heat emitters, where heat leaves the system, would ideally be shown near the right side of the schematic. More complex schematics, especially those that show many heat emitters, may require those emitters to be shown above or below other components.

Several other guidelines apply when creating piping schematics:

- Whenever possible, lines that represent piping should be drawn horizontally and vertically. Avoid angled lines whenever possible. If an angled line needs to be drawn, limit it to a 45° angle.

- The width of lines should correspond to pipe size. The larger pipe sizes in the system should be represented by wider lines in the piping schematic, and vice versa.

- Use a “fillet” (e.g., a circular arc) at locations where piping changes direction. This “softens” the appearance of the schematic and makes it more closely resemble the assembled piping.

- Minimize locations where piping crosses over other piping. When piping has to crossover other piping, include a semicircular “bridge” to clearly indicate the crossover (rather than a possible joining of the pipes where they cross).

- Minimize changes in direction in lines between any two points on the schematic. Unnecessary changes in direction add complexity to the schematic, making it harder to understand.

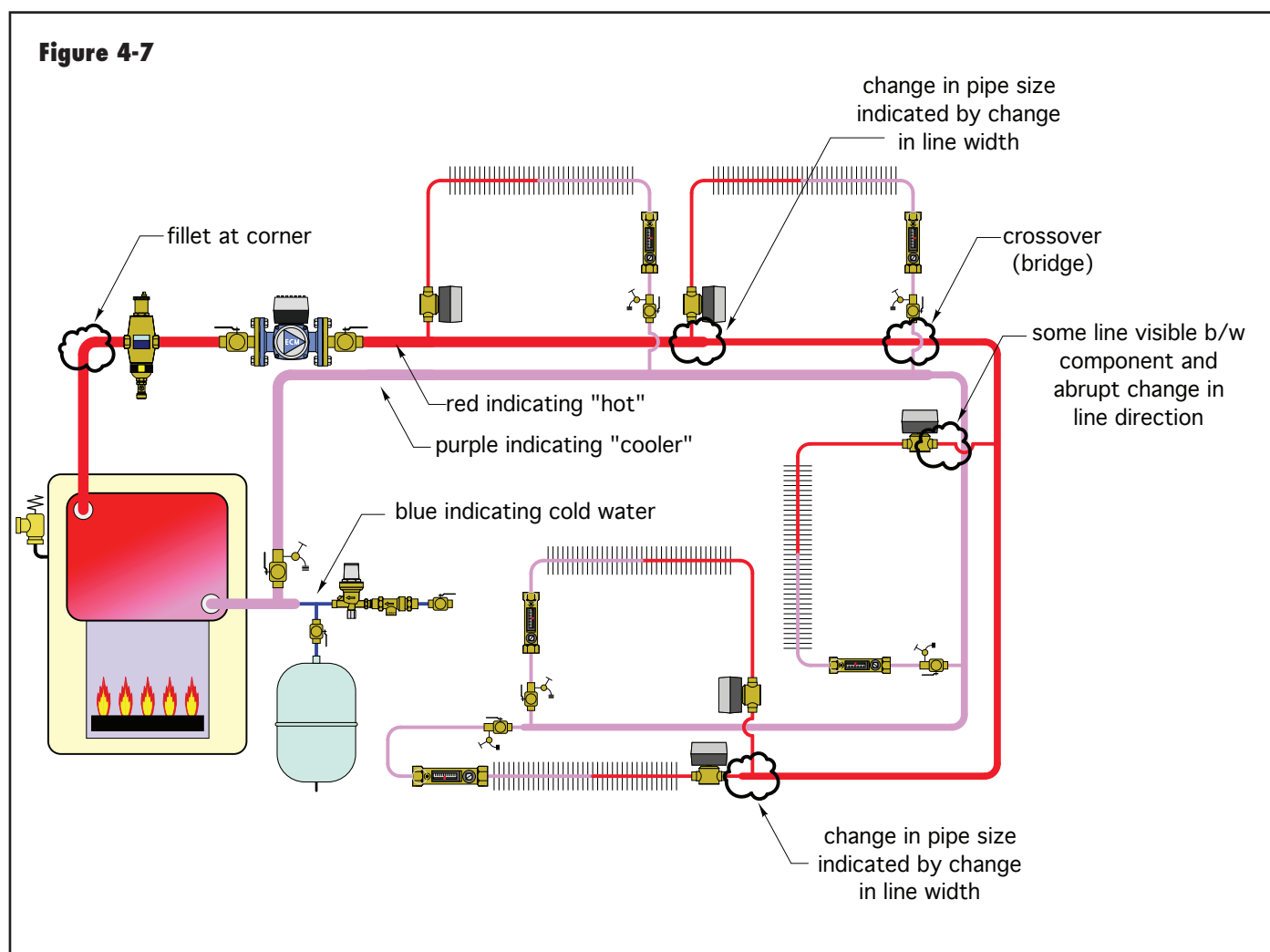

- Keep the visual density of the drawing consistent (e.g., don't crowd components tightly together in one area, while spreading them significantly farther apart in other areas of the schematic.)
- Always keep some white space around individual components. Don't place symbols so that they overlap or touch each other, unless they will be physically joined when installed. An example of the latter would be two circulators joined in a close-coupled series arrangement.
- Always keep some space between components and changes in the direction of lines.
- Whenever possible, make use of color to help identify the relative temperature of the piping during normal system operation. Use red to indicate piping that carries "hot" fluid, and blue, purple, or lighter shades of red to indicate piping carrying "cooler" fluid. This helps the person looking at the schematic understand what should be occurring during normal operation.

These guidelines are shown in the piping schematic of figure 4-7.

Once the all the symbols have been placed in the schematic, it's time to add labels. In general, any component that might be referred to in the electrical

schematic or in a schedule (i.e., a circulator schedule, or a valve schedule) should be labeled.

There is no widely accepted standard for labeling, but there may be a standard established within a company so that all drawings are consistently labeled. Figure 4-8 shows a piping schematic with component abbreviations shown in a different color from those used elsewhere in the drawing.

The circulators are labeled as (P1), (P2), etc. The temperature sensors are labelled as (S1), (S2), etc. An outdoor reset controller is labelled as (ORC). Many of the labeled components will be referenced in the electrical schematic and the description of operation.

Finally, it is important to include a piping symbol legend with any piping schematic. On larger drawings, the legend can be placed in a corner of the drawing sheet on which the piping schematic appears. When the schematic is distributed on a smaller sheet, a symbol legend, such as shown in figure 4-1, can be included as a separate sheet. The symbol legend should show all symbols that are used in the schematic. It can also include symbols that are *not* used in the schematic. In many cases, the symbol legend can be the same for all piping schematics produced by a given designer or firm.

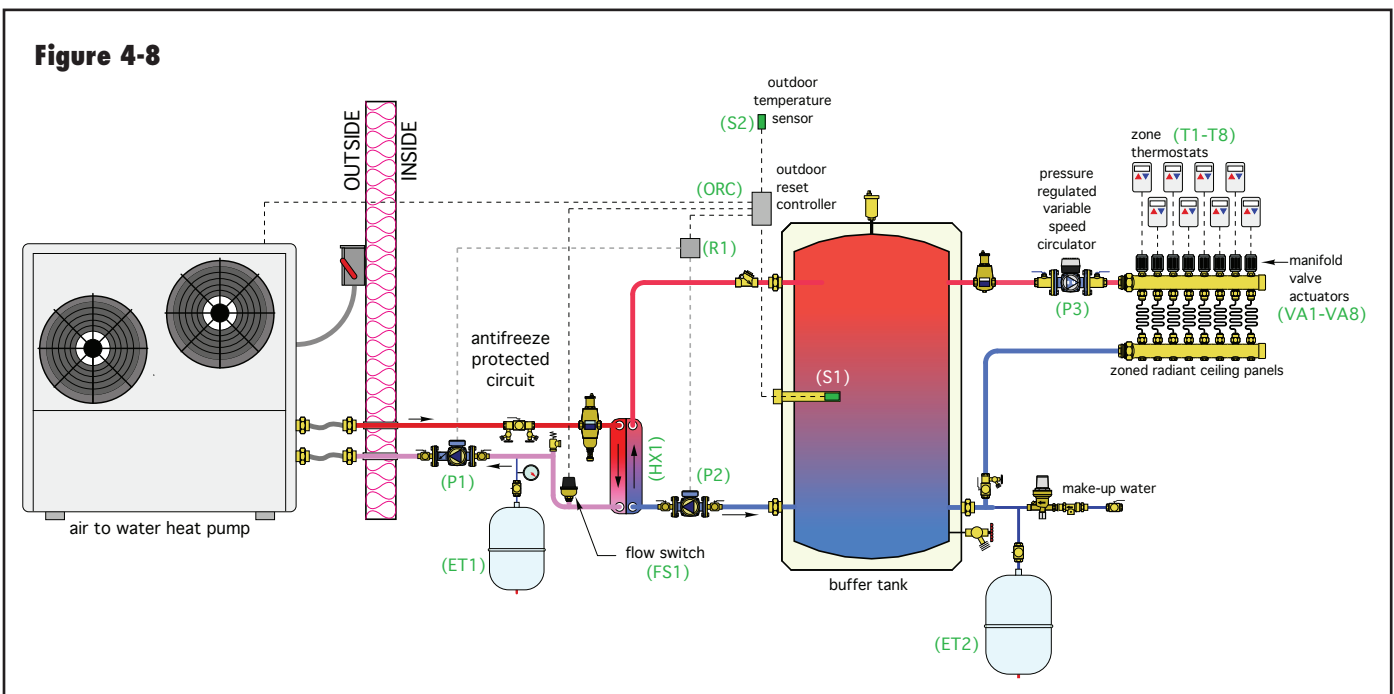

5. ELECTRICAL SCHEMATICS

All modern hydronic heating and cooling systems use electrical components. Many use multiple circulators, multiple controllers, and also have an assortment of other electrically driven devices such as zone valves, low water cutoffs, motorized mixing valves or flow switches. This electrically powered hardware requires proper selection, proper installation wiring and proper adjustment. Preparing an electrical schematic for the system is essential in accomplishing these requirements.

The purpose of an electrical schematic is to show how the electrically powered devices in the system are powered and interconnected. The devices that are typically shown in an electrical schematic include switches, relays, circulators, zone valves, motorized mixing valves, flow switches and “embedded controllers.” The latter refers to devices such as mixing valve controllers, outdoor reset controllers or multi-zone relay centers. These devices have pre-built self-contained circuits that allow them to provide specific functions. Many of these controllers also require specific adjustment to settings or DIP switches. These controllers can only provide their intended functions if they are properly interconnected with other electrical devices in the system and properly set.

Designing an electrical control subsystem for hydronic heating and cooling requires a basic knowledge of line voltage and low voltage circuits. The most commonly used line voltages in residential and light commercial systems are 120 VAC and 240 VAC single phase. The most common low voltage is 24 VAC. However, some controllers also require use of 0-10 VDC and 4-20 milliamp circuits.

Many of the control functions needed in hydronic systems are “on/off” switching. For example, a zone valve is powered on, often by 24 VAC, to open it. When power is removed, the valve closes using an internal spring. Zone circulators are turned on and off by applying or removing 120 VAC power. Many boilers and heat pumps are turned on and off by a switch or relay contact closure. Because switching is so commonly used, it’s imperative for designers to understand the terminology, and basic logic used for selecting and applying switches and relays. This knowledge is repeated applied when constructing electrical schematics.

SWITCHES

All switches have one or more contacts. These contacts must be either open or closed. There is no intermediate position between open or closed. An open contact

prevents an electrical signal from passing a given point in the circuit. A closed contact allows the signal to pass through. In the context of the controls for hydronic systems, switches are considered to be manually operated devices.

RELAYS

Relays are electrically operated switches. They can be operated from a remote location by a low voltage and low current electrical signal. They consist of two basic subassemblies: the coil and the contacts. Other parts include a spring, pendulum and terminals. These components and the basic operation of a relay are illustrated in figure 5-1.

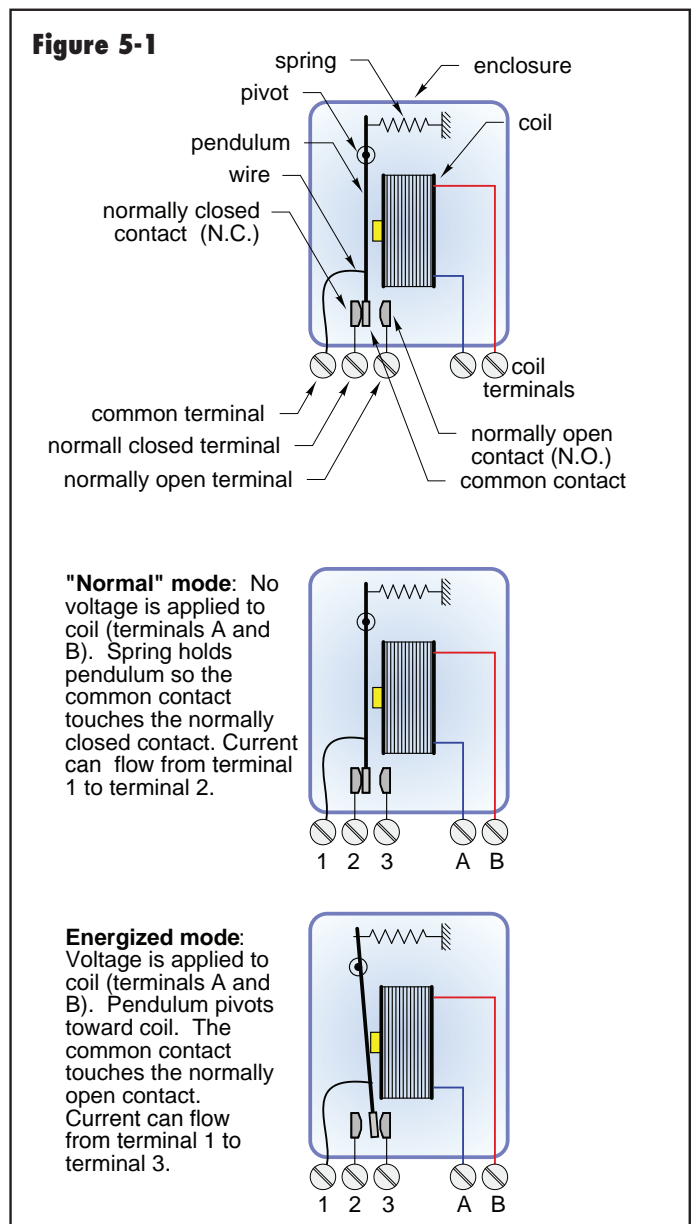

The spring holds the contacts in their “normal” position. The word “normal” implies that the coil of the relay is *not* powered. When the proper voltage is applied to the coil, and current flows through it, the coil creates an electromagnetic field. This field creates a force that pulls the “common” contact, which is attached to the pendulum, from its “normal” position to its other position. This movement slightly extends the spring inside the relay. In most relays, this action takes only a few milliseconds. A click can be heard as the contacts move from one position to the other. When voltage is removed from the coil, the magnetic field collapses, and the spring pulls the contacts back to their de-energized (e.g., “normal”) position.

Relay contacts are classified as normally open (N.O.), or normally closed (N.C.). A normally open contact will not allow an electrical signal to pass through while the coil of the relay is off. A normally closed contact *will* allow an electrical current to pass through when the coil is off.

The coil in a relay is designed to operate at a specific voltage. In heating systems, the most common coil voltage is 24 VAC. Relays with coil voltages of 12, 120, and 240 VAC are also available, and occasionally used in HVAC systems. Relays with coils designed to operate on DC voltages are also available, although less commonly used in HVAC control systems.

POLES & THROWS

Switches and relays are classified based on their poles and throws.

The number of poles is the number of independent and simultaneous electrical paths through the switch or relay. Most of the switches and relays used in heating control systems have one, two, or three poles. They are often designated as single pole (SP), double pole (DP), or triple pole (3P).

The number of throws is the number of position settings where a current can pass through the switch or relay. Most switches and relays used in heating systems have either one or two throws, and are called single throw (ST), or double throw (DT) switches.

Figure 5-2 shows the schematic symbols for both switches and relays. On the double and triple pole switches, a dashed line indicates a nonconducting mechanical coupling between the metal blades of the switch. This coupling ensures that all contacts open or close at the same time, but does not allow any electrical conductivity between adjacent contacts. Note the similarity between

the schematic symbols for switches and relays having the same number of poles and throws.

Many of the electrical schematics used for documenting hydronic heating and cooling systems use these symbols.

Although the coil and contacts associated with a relay are all contained in the same physical device, they are often

Figure 5-2

contact designation	switch contacts	relay contacts
Single Pole Single Throw SPST		
Double Pole Single Throw DPST		
Triple Pole Single Throw 3PST		
Single Pole Double Throw SPDT		
Double Pole Double Throw DPDT		
Triple Pole Double Throw 3PDT		
relay coil relay contact, normally open (N.O.) (closes when coil is energized) relay contact, normally closed (N.C.) (opens when coil is energized)		

shown in different parts of an electrical schematic. This is done to simplify the schematic. There are often multiple relay coils and multiple relay contacts in the electrical schematic. All the relay coils have the same schematic symbol. Likewise, all the normally open contacts have the same schematic symbol, and all the normally closed contacts have the same symbol. *The only way to determine which contacts are associated with a given coil is by labeling.* Such labeling is simple, but it must be consistent. For example, the coil of a given relay might be labeled (R1). If the relay only has one contact, that contact could be labeled as (R1-1). If the relay had two contacts, they could be labeled as (R1-1) and (R1-2). If it had 3 contacts, they could be labeled as (R1-1), (R1-2), and (R1-3). If the contacts in the relay are double throw (e.g., each contact has a common terminal, a normally open terminal, and a normally closed terminal), the labeling can be more detailed. For example, (R1-2 NC) would mean that the relay coil is (R1), the pole on that relay is 2, and the specific contact being referenced is the *normally closed* contact of pole 2.

Figure 5-3 shows a representation of a triple pole double throw relay. The contacts and coil are shown inside the same enclosure. Several of the contacts are labeled to show how the labeling corresponds to a specific contact or the coil. This is called a “pin-out” diagram for the relay. It’s very helpful during installation when an electrician is matching the terminal numbers on the relay with the coil and contact symbols used in the electrical schematic.

There is a distinct difference between the symbols for a normally open contact and a normally closed contact. A *normally closed contact will always have a 45° slash mark across the contacts, indicating that electrical current can pass through when the coil of the relay is unpowered.*

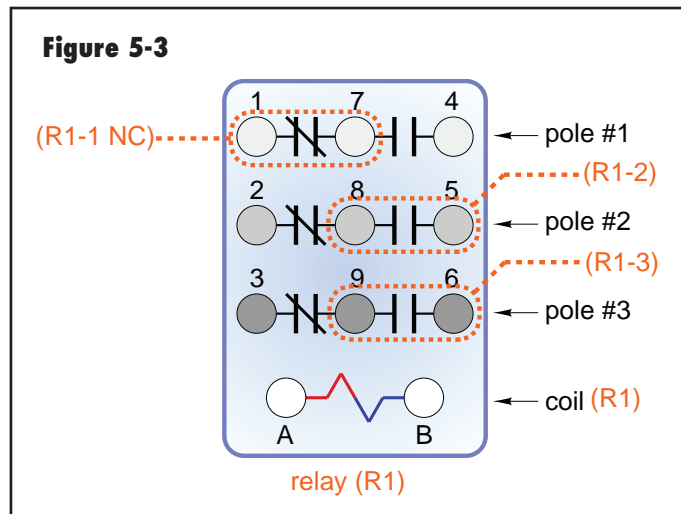

Normally open contacts are more common in the types of electrical schematics used to document hydronic systems. To ensure that a normally closed contact is not mistaken for a normally open contact, it is good practice to add the letters NC at the end of the label. For example, (R1-1 NC) in figure 5-3 implies relay coil (R1), pole #1, and the normally closed contact.

HARD-WIRED LOGIC

One way to create operating logic for a control system is by connecting switch contacts, or relay contacts, in series, parallel, or combinations of series and parallel. Figure 5-4 shows basic series and parallel arrangements.

Contacts in series represent an “AND” decision. For an electrical signal to reach a driven device, all series-connected contacts must be closed simultaneously.

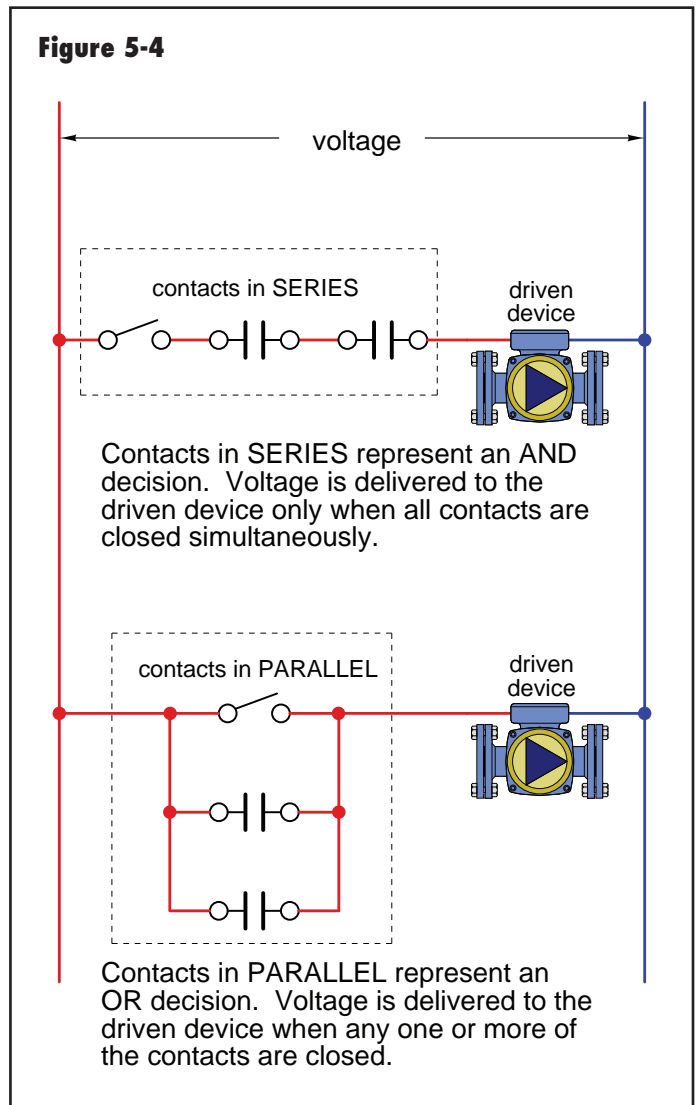

Contacts in parallel represent an “OR” decision. If any one or more of the contacts are closed, the electrical signal passes through the group of contacts to operate the driven device.

When switch contacts, relay contacts and contacts within embedded controllers are physically wired together in a given manner, they create hard-wired logic. Such logic determines exactly how the control system functions in each of its operating modes. Some operating modes are planned occurrences, while others may be fail-safe modes in the event a given component does not respond properly.

LADDER DIAGRAMS

A ladder diagram is the preferred method for documenting the electrical interconnection of devices used in a hydronic heating or cooling system. They can then be used for design, installation and troubleshooting.

Ladder diagrams have two sections: the line voltage section at the top, and the low voltage section at the bottom. A step-down transformer separates the two sections. The primary winding of the transformer is connected to line voltage in the upper portion of the diagram. The secondary winding of the transformer supplies power to the lower portion of the diagram. In North America, most heating and cooling systems operate with a secondary voltage of 24 VAC.

An example of a simple ladder diagram is shown in figure 5-5. The vertical lines can be thought of as sides of an imaginary ladder. Any horizontal line connected between the two sides is called a “rung.” A rung connected across the line voltage section is exposed to 120 VAC. A rung connected across the low voltage section is usually exposed to 24 VAC. The overall ladder diagram is constructed by adding the rungs necessary to create the desired operating modes of the

system, and show how all the devices necessary for those modes are to be connected. The vertical lines of the ladder can be extended as necessary to accommodate all required rungs.

Relays are often used to operate line voltage devices such as circulators, oil burners or blowers based on a “call” for operation from a low voltage device such as a thermostat. The ladder diagram shown in figure 5-5 shows how this is accomplished.

When the thermostat (T1) calls for heat, a normally open contact within the thermostat closes. This allows 24 VAC to reach the coil of relay (R1). The normally open contact (R1-1) in the line voltage portion of the ladder diagram closes to pass 120 VAC to the circulator (P1). Although this example is relatively simple, it illustrates the basic use of both the line voltage and low voltage sections of the ladder diagram.

Notice that the coil and contacts of the same relay appear in different sections of the ladder diagram. When more than one relay is present in the diagram, it’s critically important to use consistent labeling to know which relay contacts are associated with a given relay coil.

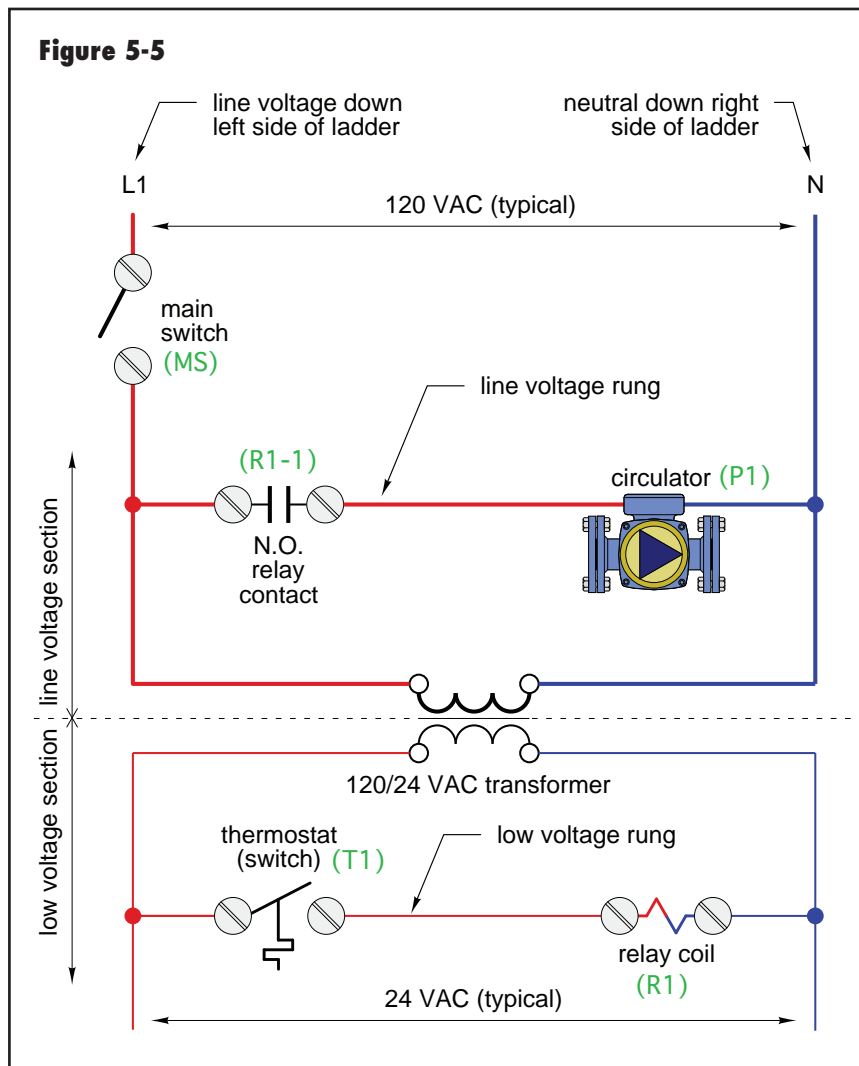
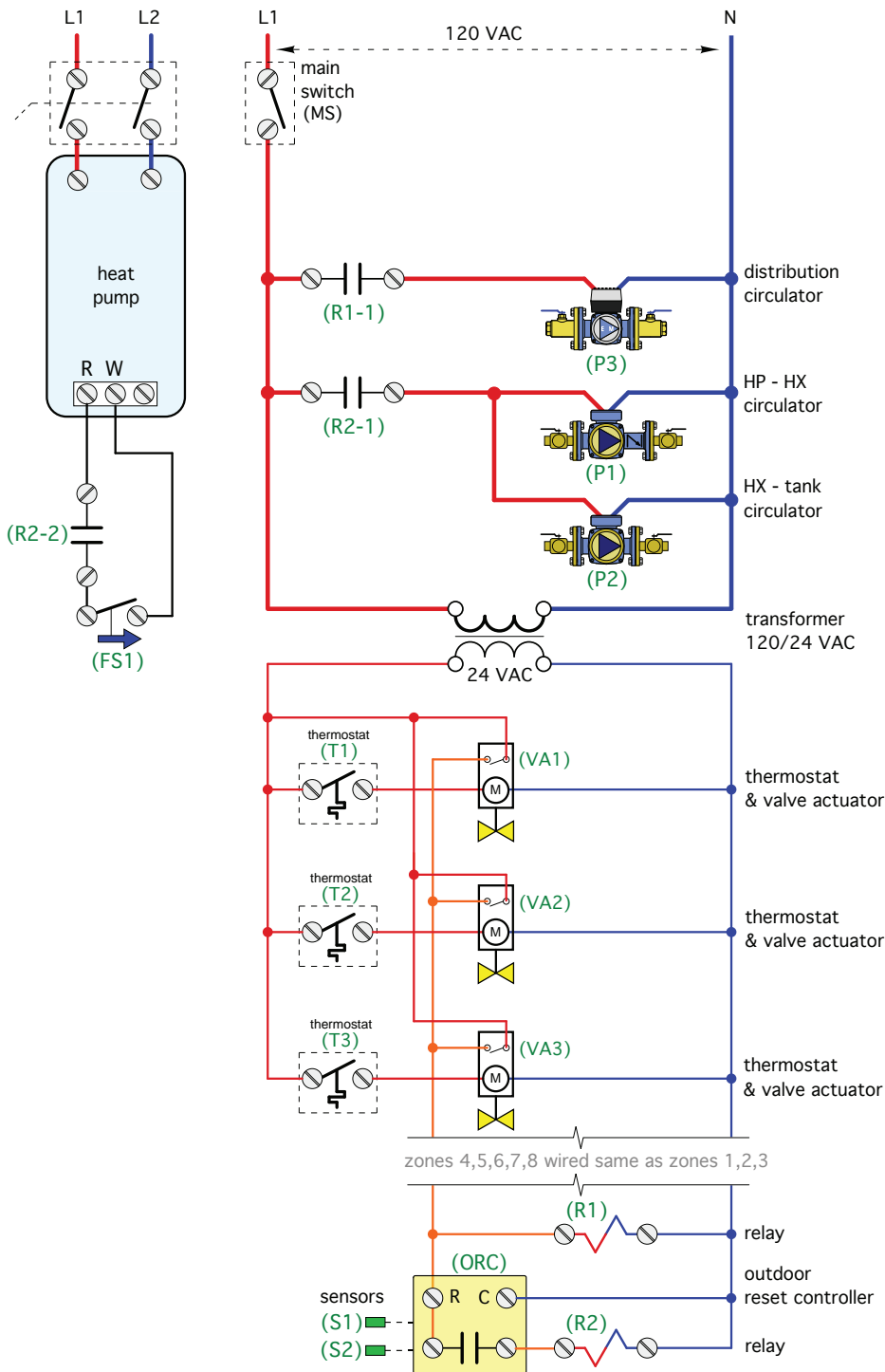

Figure 5-6



It is also common to show a main switch at the top of the ladder. When open, the main switch prevents any electrical signal from passing downward into the ladder diagram, and thus would totally prevent any electrical components shown in the ladder diagram from operating. For systems powered by 120 VAC, the main switch would be installed in the live lead (e.g., the left vertical line of the ladder). For systems supplied by 240 VAC, a double pole main switch would be used to open both live leads simultaneously.

More complex ladder diagrams are developed by placing schematic symbols for additional components into the diagram. Some of these components might be simple switches or relays, others might be special purpose “embedded controllers” that provide very specific control functions, such as temperature setpoint control, differential temperature control or outdoor reset control. An example of a ladder diagram with several rungs and an embedded controller (labelled as ORC, for outdoor reset controller) is shown in figure 5-6.

Although most of the electrical components in the system, such as circulators, zone valves, an outdoor reset controller, and thermostats, are shown within the main ladder, the heat pump, which is powered by a dedicated circuit, is shown outside the ladder.

Notice that all the devices are labeled **(shown in green)**. A typical relay coil is labeled as (R1) or (R2), and its associated contacts are labeled as (R1-1) or (R2-2). These designations

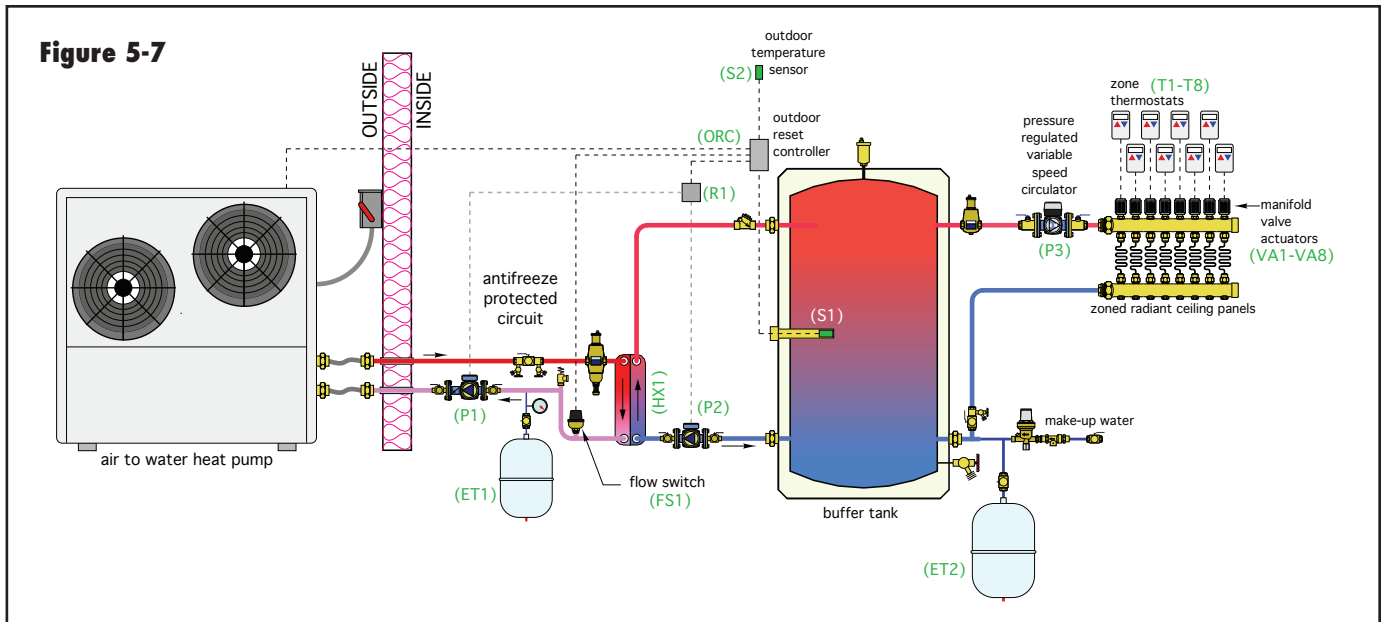

associate specific contacts with the relay coil that operates them. For example, relay coil (R1) operates relay contact (R1-1), and relay coil (R2) operates contacts (R2-1) and (R2-2). The number after the dash indicates the pole number of the relay contact. For example, R2-1 designates pole #1 on relay (R2), and R2-2 designates pole #2 on the same relay. Such designations are critically important when interpreting the operating logic associated with the ladder diagram.

The single embedded controller in figure 5-6 is identified as (ORC), which stands for outdoor reset control. It's shown as a simple box with four terminals and two attached sensors. This is a simplified rendering that only shows the terminals relevant to this particular application. A fully detailed symbol for the embedded controller could be used, but it will add to drawing complexity.

The ladder diagram in figure 5-6 is also shortened by omitting some redundant detailing for the zone thermostats and valve actuators, and inserting break lines with a note: "Zones 4,5,6,7,8 wired same as zones 1,2,3." This is done to conserve vertical space without omitting unique details.

There are also some notes on the right side of the ladder making reference to specific functions or hardware associated with a rung. These are optional.

Figure 5-7 shows the piping schematic of the system associated with the ladder diagram shown in figure 5-6.

Notice that the electrically driven components on the piping schematic have corresponding designations on the ladder diagram. This makes it easy to cross reference between the two diagrams when examining the operating logic, or troubleshooting the installed system.

MULTI-ZONE RELAY CENTERS

Some controllers provide all the circuitry and logic necessary to operate simple hydronic systems. One example is a multi-zone relay center such as shown in figure 5-8.

Multi-zone relay centers are a commonly used controller in multi-zone hydronic systems using either zone circulators or zone valves. In basic applications, all the circuitry and operating logic required to operate the system is contained in the multi-zone relay center, the zone thermostats and the heat source. In such cases, it is usually not necessary to draw a ladder diagram for the system. Instead, the components that are controlled by the multi-zone relay center can be shown directly connected to it, as shown in figure 5-9.

There are times when multi-zone relay centers will only be a *part* of an overall control system that includes other embedded controllers and perhaps other relays or switches. In such cases, the multi-zone relay center can be treated as an embedded controller. Figure 5-10 shows an example.

Figure 5-8

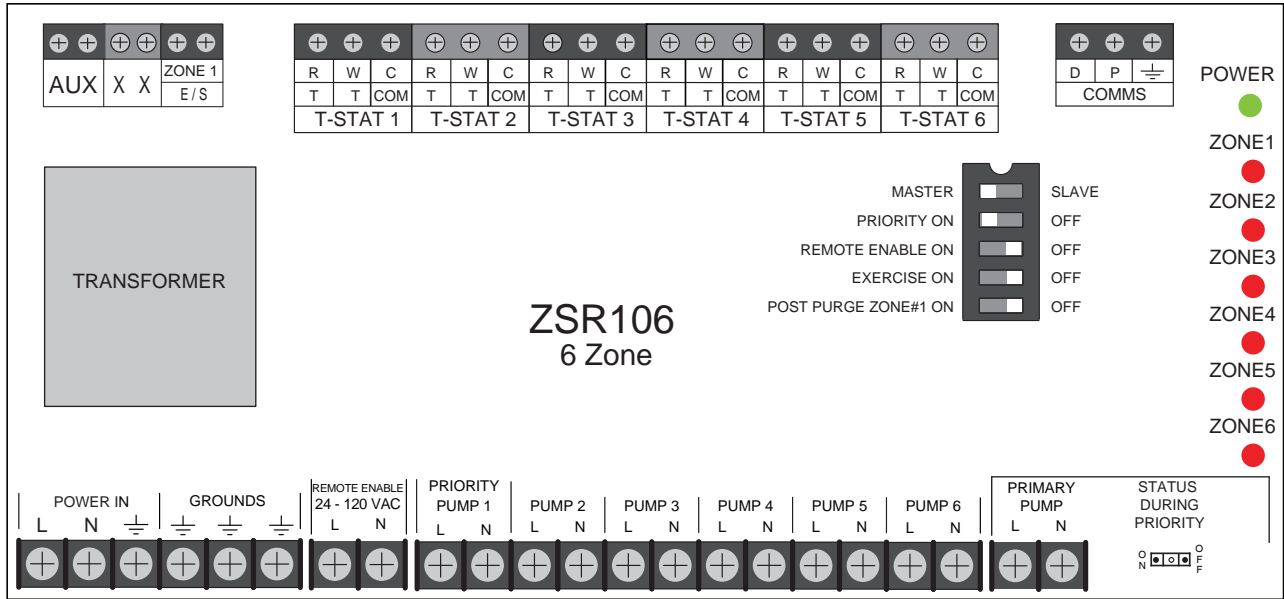

Figure 5-9

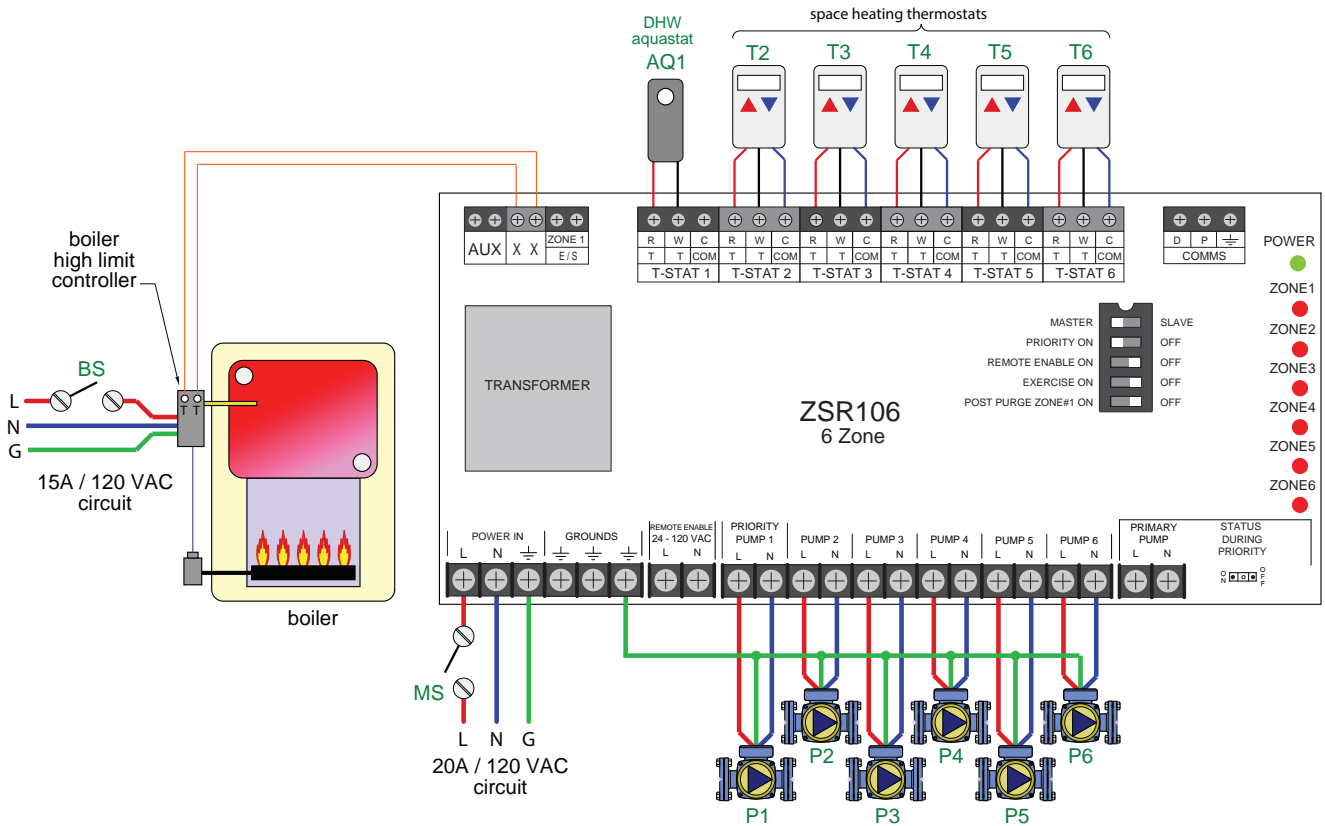

Figure 5-10

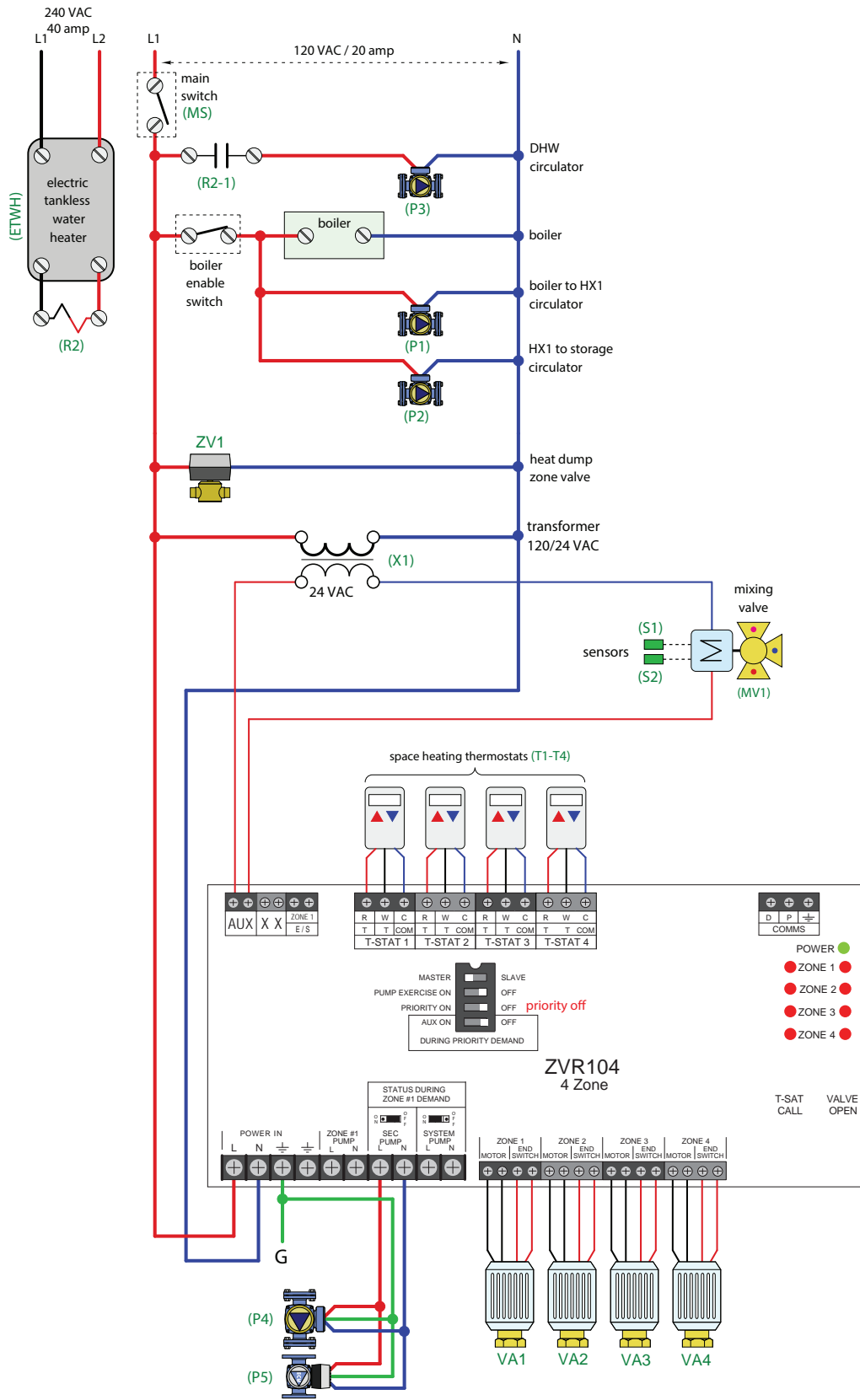

Figure 5-11

T156 settings:

ΔT SETPOINT = 5 °F
 ΔT DIFFERENTIAL = 3 °F
 SOURCE MIN SETPOINT = 70 °F
 SOURCE MIN DIFFERENTIAL = 5°F
 SOURCE MAX SETPOINT = 210 °F
 SOURCE MAX DIFFERENTIAL = 5 °F
 UNITS = °F

T261 settings:

DIP switch settings:
 DIP #1 set to ADVANCED
 DIP #2 ROTATE set to OFF

TERMINAL UNIT = 4**
 BOIL DSGN = 170 °F
 BOIL MAX = 180 °F
 BOIL MIN = 110 °F
 BOIL INDR = 60 °F
 BOIL DIFF (FIXED @ 10 °F)
 ROOM OCC = 70 °F
 ROOM UNOCC = 70 °F
 OUTDR DSGN = -5 °F
 WWSD = OFF
 FIRE DELAY = 3 minutes

** the default temperatures setting for the terminal unit selection will be overridden by the BOIL settings

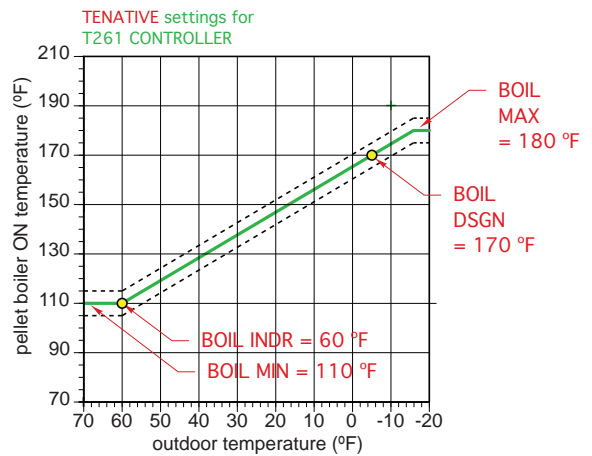

EMBEDDED CONTROLLER SETTINGS

Designers should familiarize themselves with the full capability of any embedded controllers used in a system before adding those controllers to the electrical schematic, or describing them in the description of operation.

Whenever an embedded controller is used, it is also important to specify all initial parameter settings and DIP switch positions. Even the best-planned control system will not produce expected results if the controllers do not have proper settings. Ideally, all the possible settings of a given controller should be listed, even if they are default values, or parameters that are not used in a particular application. Identify these settings as “initial” since they might be changed when the system is commissioned or otherwise adjusted in the future. Figure 5-11 shows an example of an initial settings table for two embedded controllers.

GUIDELINE FOR LADDER DIAGRAMS

Several of the guidelines discussed for piping schematics also apply to electrical schematics. They include:

- Always look for opportunities to *simplify* the schematic, *but without changing the control actions it represents*. This includes minimizing changes in the direction of lines, and eliminating crossovers whenever possible.

- Create a legend of electrical component symbols and bring it into the drawing workspace. Select a symbol from the legend by duplicating it and then dragging the duplicate to where it’s needed in the schematic. This preserves the original legend, and eliminates having to redraw any symbols, regardless of how many times they are used. Appendix B shows a suggested symbol legend for the types of electrical devices commonly used for controlling hydronic systems.

- Place schematic symbols “on top” of lines representing conductors by using layers within the CAD software. This allows the symbols to be easily moved, if necessary, without having to repair gaps in the lines.

- Always draw the line voltage portion of a ladder diagram above the low voltage portion.

- Use wider lines to represent line voltage circuitry and narrower lines for the lower voltage circuitry. This adds clarity and understanding.

- Use different color lines to represent the supply side of a voltage (e.g., 120 VAC or 24 VAC) versus the return side (e.g., neutral, or the common side of a transformer).

- Include a main switch at the top of the line voltage portion of the ladder that can remove power from the entire ladder when opened.

- Specify the voltage and ampacity of the circuit that supplies power to the control system. This should be noted at the top of the ladder diagram.
- Always try to align similar components that appear on multiple rungs. Examples include relay coils, relay contacts, thermostats and circulators. Alignment improves the appearance of the drawing.
- Always indicate the secondary voltage of the transformer.
- Show manually-operated switches in their open position.
- Always label devices in the ladder with abbreviations that can be cross-referenced to the piping schematic and description of operation.
- Always use a dot to indicate an electrical bond at a “T” connection.

6. DESCRIPTION OF OPERATION

Piping and electrical schematics show the relative placement of piping and electrical components. However, they don’t “explain” exactly how the system should work once these components are assembled. As such, schematics alone are not sufficient to properly document a hydronic heating or cooling system. Another document, called the “Description of Operation” should be developed to provide this explanation.

A description of operation is useful in several ways. First, it forces the designer to be sure *they* fully understand how the system operates, and that it is fully documented in the piping and electrical schematics. It also helps the designer spot any inconsistencies or missing details, especially in regards to how the system is controlled. For example, when a description of operation is written, and it describes when circulators (P1, P2, and P3) should operate, but the piping schematic shows *four* circulators (P1, P2, P3, P4), it is obvious that the description of operation is not complete, or perhaps the necessary details for operating circulator (P4) have not been included in the electrical schematic.

Second, a description of operation explains what the installer should observe when the system is put into operation. Just because all the devices in the system appear to operate, doesn’t imply that they are operating *correctly*, or in coordination with each other. An installer’s interpretation of what is correct system operation could be different from what the designer intended. A detailed description of operation should clarify correct system operation.

Third, descriptions of operation are vitally important when the system is undergoing troubleshooting, especially if the service technician is not already familiar with the system, which is often the case. The sequences described in the description of operation can be compared to what is being observed, and inconsistencies are likely to point to a problem.

WRITING A DESCRIPTION OF OPERATION

The person who designs the system should write the description of operation. In doing so, the designer should “narrate” what happens in the system during each *mode* of operation.

Examples of modes of operation would include: space heating, domestic water heating, cooling, snowmelting,

garage heating, pool heating, or descriptions of specialized hardware such as a pellet-fired boiler or solar thermal collector subsystem, especially when that specialized hardware includes an embedded controller.

The description of operation for each mode should begin with an explanation of what “calls” for that mode to commence. For example: *upon a call for space heating from thermostat (T1), 24 VAC is passed to relay coil (R1).* In this case, space heating is initiated when the contacts in thermostat (T1) close — a very common way, but not the only way, of initiating heat input to a space. This sentence describes the first and second actions that take place in this mode operation. The first action is the call for heat by thermostat (T1), and the second action is 24 VAC being applied to the coil of relay (R1).

From this point, the description of operation just continues to explain what happens next. For example, the next sentence might say: *Relay contact (R1-1) closes, passing 120 VAC to circulator (P1).* The next sentence might say: *Relay contact (R1-2) closes to complete a circuit between the (TT) terminals of the boiler high limit controller, enabling the boiler to operate.*

Notice that each sentence contains references to specifically identified components, such as (T1), (P1), (R1-1), and (R1-2). These designations appear in the electrical schematic, and in the case of circulator (P1), also in the piping schematic. This cross-referencing allows the person reading the description of operation to quickly reference both the piping and electrical schematics, and to better understand what is accomplished by each control

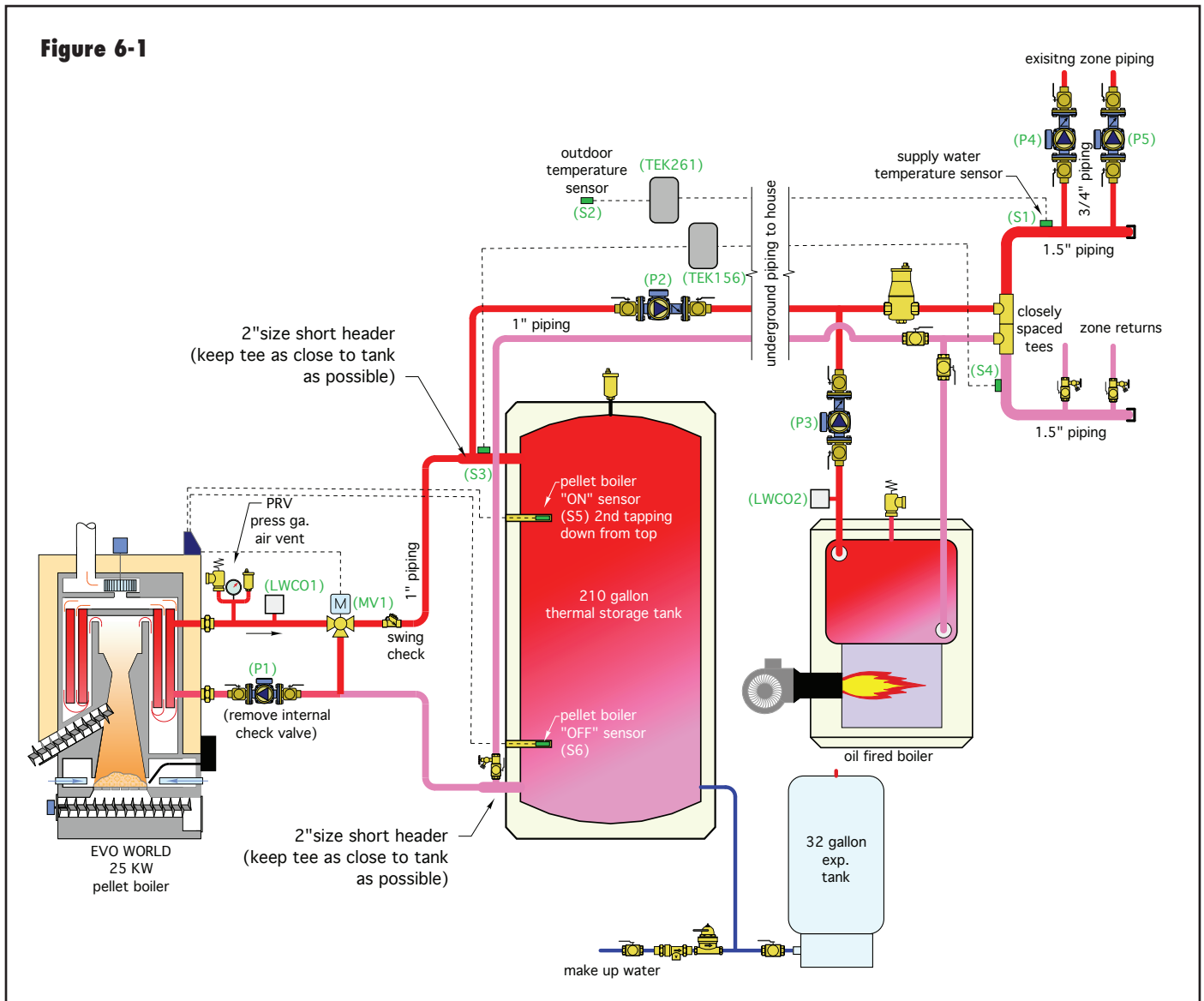
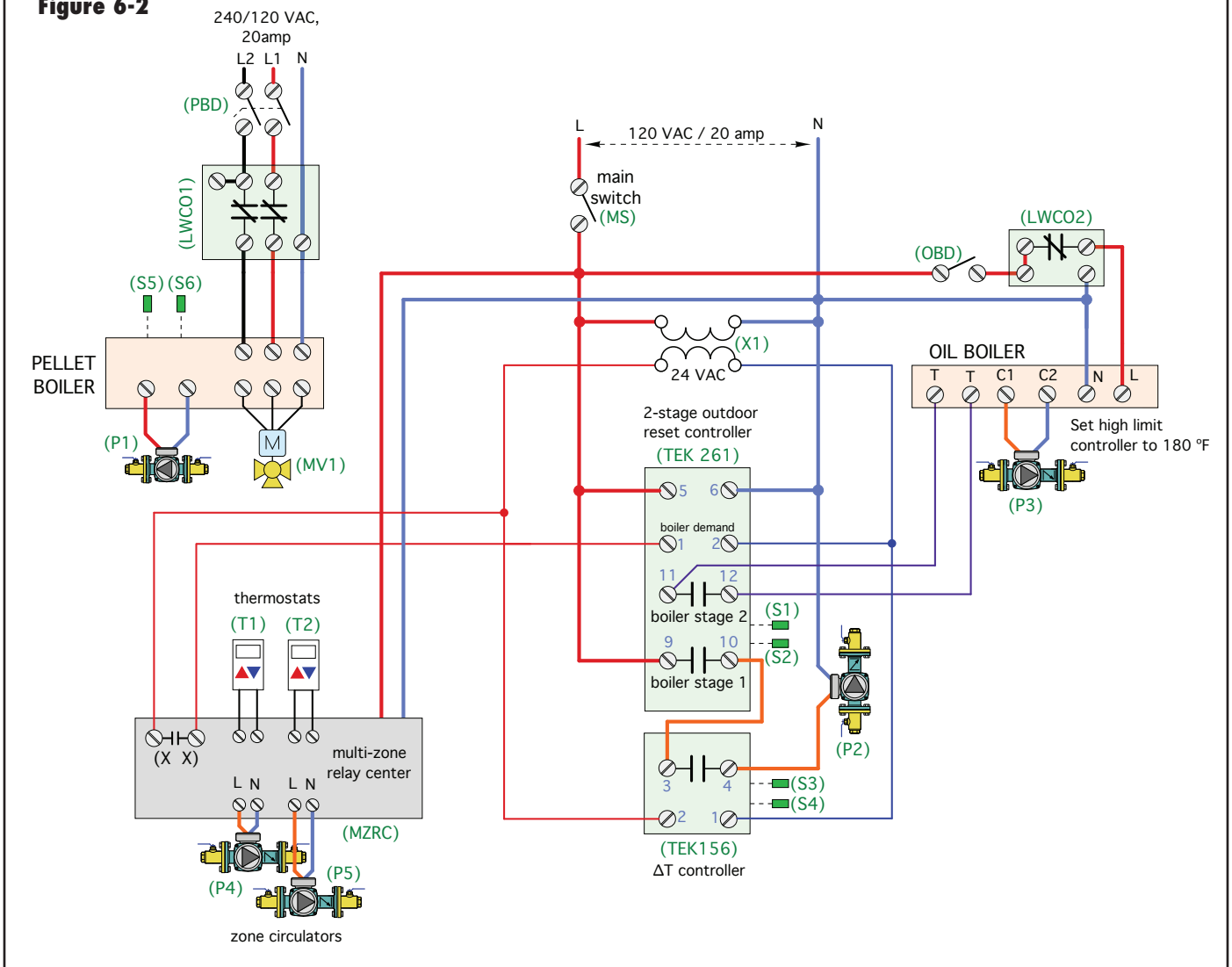

Figure 6-2



action being described. It is very important to make frequent references to specifically identified components when writing a description of operation. Likewise, it is very important to consistently and accurately label these components in any schematic where they appear.

Keep in mind that there is no single description of operation that is “right,” while all other variations on that description are “wrong.” Different designers will inevitably word their descriptions of operation differently. That’s fine. The two questions by which to judge the suitability of a description of operation are:

1. Is it sufficiently detailed that an installer with a basic knowledge of hydronics can assemble and commission the system as intended?

2. Can a service technician with a basic knowledge of hydronics, but who has no previous experience with the system, understand how that system should operate?

Figure 6-1 is a piping schematic for a specific system in which a pellet boiler and associated thermal storage tank are being added as the primary heat source, while the existing oil-fired boiler is retained for supplemental heating.

Notice the abbreviations for components such as circulators, mixing valve, and sensors.

Figure 6-2 shows the electrical schematic for this system.

The following is a description of operation for this system.

DESCRIPTION OF OPERATION:

SYSTEM POWER: *The control system, oil-fired boiler, and all circulators other than (P1) are powered by a 120 VAC/20-amp dedicated circuit. The pellet-fired boiler, circulator (P1), and motorized mixing valve (MV1) are powered by a dedicated 240/120 VAC/20-amp circuit.*

PELLET BOILER OPERATION: *The pellet boiler is enabled to operate on its own internal controller whenever the pellet boiler disconnect (PBD) is closed, and water is detected by the low water cutoff (LWCO1). The pellet boiler fires whenever the upper tank temperature sensor (S5) drops to 150°F or less. It continues to fire until the lower tank sensor (S6) reaches 175°F. This operation continues 24/7, and is completely under the control of the pellet boiler, and not dependent on the status of any heating zone. The pellet boiler turns on circulator (P1), and manages operation of the 3-way motorized anti-condensation mixing valve (MV1).*

SPACE HEATING: *When either zone thermostat (T1) or (T2) calls for heating, the associated zone circulator (P4) or (P5) is turned on by the multi-zone relay center (MZRC), and the isolated relay contact (X X) in the multi-zone relay center closes. The closed (X X) contact passes 24 VAC to the “boiler demand” terminal (#1) of the (TEK261) controller. When the (TEK261) receives the 24 VAC boiler demand, it boots up and measures the current outdoor temperature at sensor (S2). It uses this temperature, along with its settings, to calculate the current target water temperature at the supply sensor (S1). It then compares the measured temperature at sensor (S1) to the calculated target temperature. If the measured temperature at (S1) is 5°F or more below the calculated target temperature, the first stage contacts in the (TEK261) close. This passes 120 VAC to the normally open contact in the (TEK156) differential temperature controller. If the temperature at the upper header of the thermal storage tank, measured by sensor (S3), is at least 5°F above the temperature on the return side of the distribution system, measured by sensor (S4), the normally open contact in the (TEK156) closes to supply 120 VAC to circulator (P2). Circulator (P2) moves heated water from the upper thermal storage tank header, and the pellet-fired boiler if it is operating, to the closely spaced tees in the distribution system.*

If the (TEK261) determines the target temperature is not going to be met in reasonable time, it closes its second stage contacts. If the oil boiler disconnect (OBD) is closed, and water is detected by the low water cutoff (LWCO2), circulator (P3) turns on. If the water temperature in the oil-fired boiler is less than 175°F, the oil burner fires. Heated water from the oil-fired boiler passes to the closely spaced tees in the distribution system.

The oil-fired boiler continues to operate along with circulator (P2) until and unless the return water temperature measured at sensor (S4) increases to within 2°F below the temperature at the upper thermal storage tank header, measured at sensor (S3). If this 2°F differential occurs, the contact in the (TEK156) opens, turning off circulator (P2) to prevent heat from the oil-fired boiler from being inadvertently added to thermal storage. When the temperature at sensor (S3) increases due to pellet boiler operation so that it is again 5°F or more above the return water temperature at (S4), circulator (P2) will again be turned on to move heat from thermal storage into the distribution system. As long as the second stage contacts in the (TEK261) controller are closed, the oil-fired boiler will continue to fire, whether or not the thermal storage tank circulator (P2) is operating. This coordinated operation of the heat sources continues as long as a demand for heat from either zone thermostat (T1) or (T2) is present, or until the supply water temperature at sensor (S1) climbs to 5°F above the current target supply temperature, at which time both first and second stage contacts on the (TEK261) open, turning off circulator (P2), the oil-fired boiler and circulator (P3).

7. ADDITIONAL DOCUMENTATION

The previous three sections have discussed the need for a piping schematic, an electrical schematic and a description of operation as the primary means of documenting the design of a hydronic system. This section discusses additional means of conveying information related to design, installation and future servicing of hydronic systems. These include:

- Component schedules
- General drawing notes
- Drawings for specific installation details
- Photos of intended installation details
- System service log
- System binder

COMPONENT SCHEDULES

The term “schedule,” as used in the context of documentation, refers to a listing of individual devices that all fit into a category. For example, a circulator schedule would be a listing of all circulators in the system. Each circulator would be identified by the same abbreviation it has in the piping schematic, electrical schematic and description of operation. An example of a circulator schedule is shown in figure 7-1.

In addition to the abbreviation used to identify the circulator, and the specific make and model, the circulator schedule can list supporting information such as the type of flanges to be used, the motor speed setting, if the circulator is to have an internal check valve, the voltage the circulator operates at, and the amperage required at full load.

The purpose of a schedule is to list information that is too lengthy or detailed to be listed near a component on the piping or electrical schematics.

Other schedules can be developed for groups of similar components, such as circuit-balancing valves, heat emitters or radiant panel circuits. An example of the latter

is shown in figure 7-2, along with the corresponding circuit layout drawing.

Some CAD programs have built-in features for creating schedules. Another option is to use spreadsheet software to quickly build the table, and if necessary, perform edits to that table as the design is developed. Once the schedule is finalized, it can be copied and pasted into the CAD drawing file as a JPEG, PDF, or other compatible file format.

GENERAL DRAWING NOTES

Due to space limitations, it's usually not possible to show all the information on how the system should be installed directly on the piping or electrical schematics. On some projects, this additional information is presented as detailed specifications, following the CSI (Construction Specifications Institute) Master Format. However, on smaller projects this information can be conveyed using general drawing notes that describe expected details that often occur at many locations within the system. The text below is an example of general drawing notes applying to the hydronic piping in a specific system.

GENERAL PIPING NOTES:

1. All rigid tubing used for space-heating circuits shall be type M copper soldered with 50/50 solder.
2. All copper tubing used for potable water shall be type L joined with non-lead solder.
3. All tubing in the mechanical room shall be supported on Unistrut® or equivalent channell/clamp system.
4. Do not mount any electrical hardware below servicable piping components, including valves or circulators.
5. Provide brass isolation flanges with integral ball valves on all circulators.
6. Provide a minimum of 10 pipe diameters of straight pipe on the inlet side of all circulators.
7. Provide a minimum of 10 pipe diameters of straight pipe upstream of all check valves.
8. Provide a minimum of 10 pipe diameters of straight pipe upstream of all flow meters or balancing valves.
9. Zone valves shall be Caleffi 3/4" CxC, normally closed, 24 VAC, 4-wire.

Figure 7-1

CIRCULATOR SCHEDULE:

Circulator	Circulator Location	Circulator model	circulator trim	notes
P1	earth loop circulator	Grundfos UPS26-150 (speed 3)	1.25" webstone isolation flanges	remove internal check valve if present
P2	heat pump to buffer tank	Grundfos alpha in UPS 15-58 FC speed 3 mode	1" webstone isolation flanges	circulator must have internal check valve
P3	future cooling circulator	NOT CURRENTLY SPECIFIED	N/A	N/A
P4	boiler circulator	Grundfos alpha in UPS 15-58 FC speed 3 mode	1.25" webstone isolation flanges	circulator must have internal check valve
P5	House heating circulator	Grundfos alpha in auto adapt ΔP mode	1.25" webstone isolation flanges	remove circulator check valve if present
P6	solar drainback circulator	Taco 009 VS Solar (drainback)	3/4" webstone isolation flanges	circulator must have internal check valve
P7	garage floor heating	Grundfos alpha in UPS 15-58 FC speed 3 mode	1" webstone isolation flanges e	circulator must have internal check valve
P8	DHW recirculation pump	Grundfos UP10-16BN5	1/2" FPT connection	use 1/2" ball valve on each port

Figure 7-2

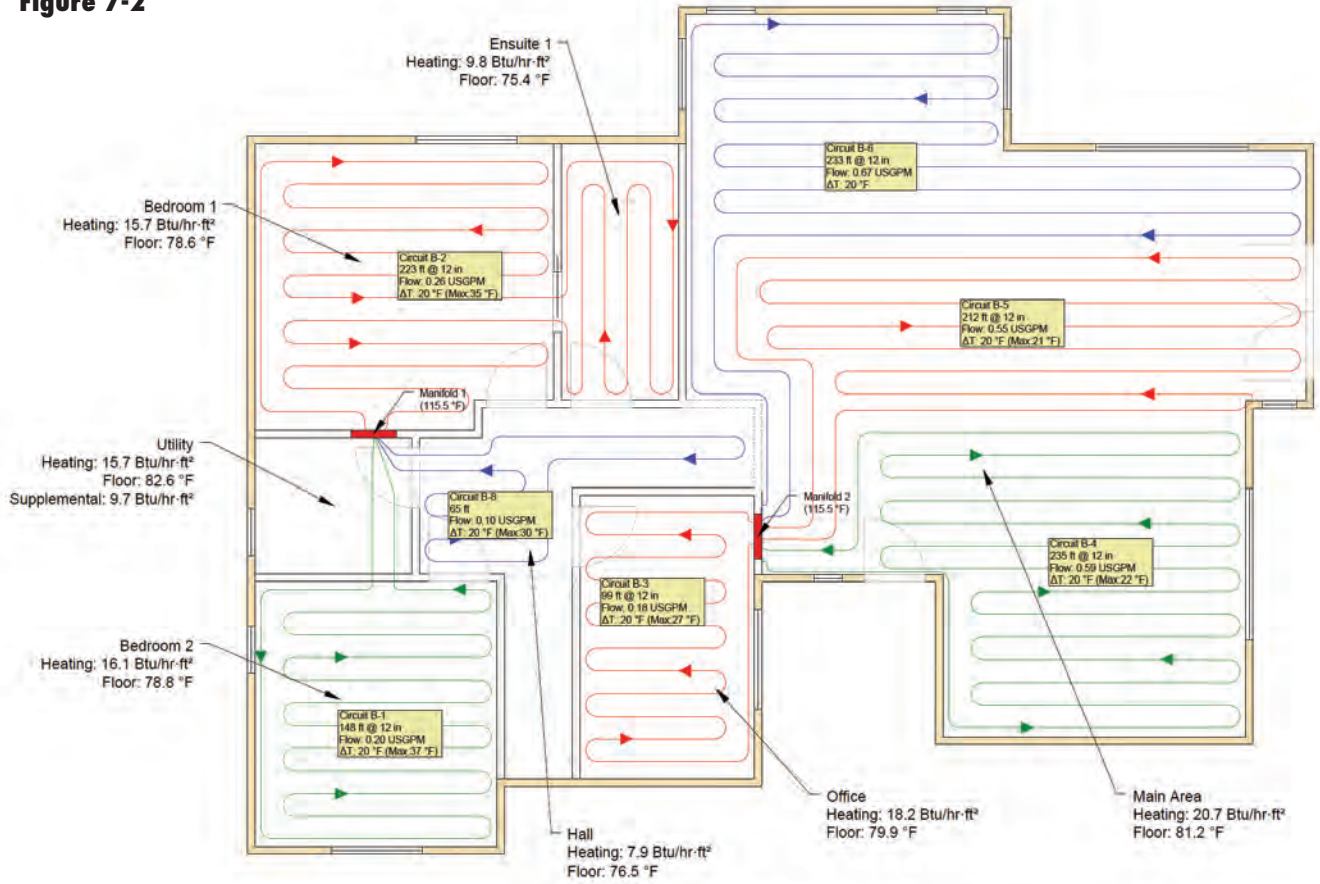

Circuit Information							
Number	Manifold	Rooms	Tube Size	Length (ft)	Flow (USGPM)	Head Loss (ft water)	Total Load (Btu/hr)
B-1	Manifold 1	Bedroom 2	1/2"	148	0.20	1.3	3,263
B-2	Manifold 1	Bedroom 1, Ensuite 1	1/2"	223	0.26	2.5	3,618
B-3	Manifold 2	Office	1/2"	99	0.18	0.7	2,216
B-4	Manifold 2	Main Area	1/2"	235	0.59	5.7	5,713
B-5	Manifold 2	Main Area	1/2"	212	0.55	4.5	5,219
B-6	Manifold 2	Main Area	1/2"	233	0.67	7.1	5,974
B-8	Manifold 1	Hall	1/2"	65	0.10	0.3	1,062

Courtesy of Avenir Software

- 11. All system piping (other than on the earth loop of the heat pump) shall be pressure tested and washed using Rhomar Hydro-Solv 9100 solution (as per Rhomar instructions). System shall then be thoroughly flushed and filled with clean water.
- 12. All system water shall be demineralized to a level of 10-30 PPM total dissolved solids.

- 13. Route PVC condensate drainage piping from the boiler to the condensate neutralizing station, then to the floor drain.
- 14. Wipe all solder joints and clean all residual flux from the exterior of piping and fittings using detergent and water.
- 15. Insulate all domestic hot water piping with 1/2" wall thickness closed-cell foam insulation.

Figure 7-3

EARTH LOOP CROSSECTION

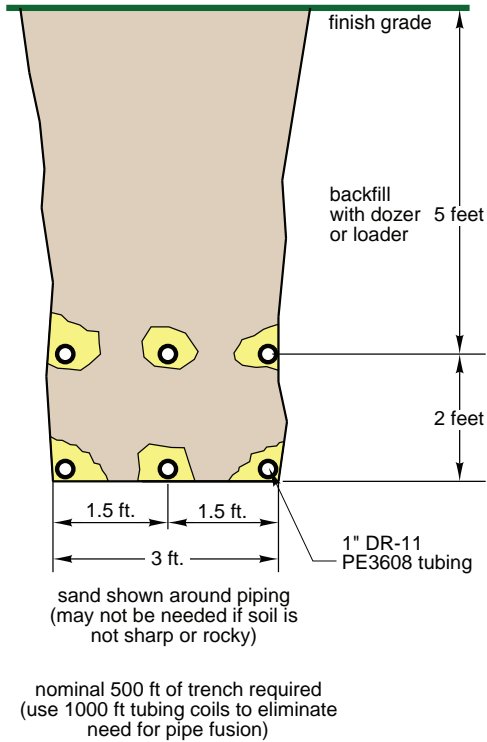

General drawing notes can be developed to whatever level of detail is deemed necessary. In most cases, general drawing notes should cover the installation details for:

- System piping and piping insulation
- System wiring
- Combustion appliance venting and air supply
- Specialty installation details such as earth loops for geothermal heat pumps, or collector mounting for solar thermal collectors.

DRAWINGS FOR SPECIFIC INSTALLATION DETAILS:

Some systems require specific installation details that are easier to communicate using a drawing or a photo, rather than through notes. As an example, figure 7-3 shows a specific installation detail, represented as a cross sectional drawing, for a horizontal earth loop to be used in a specific geothermal heat pump system.

Figure 7-4 shows a mounting detail for a solar thermal collector, along with two photos that further illustrate how the mounting hardware is to be installed.

Figure 7-5 shows the cross section of an “above-floor” tube & plate radiant panel installation.

Figure 7-4

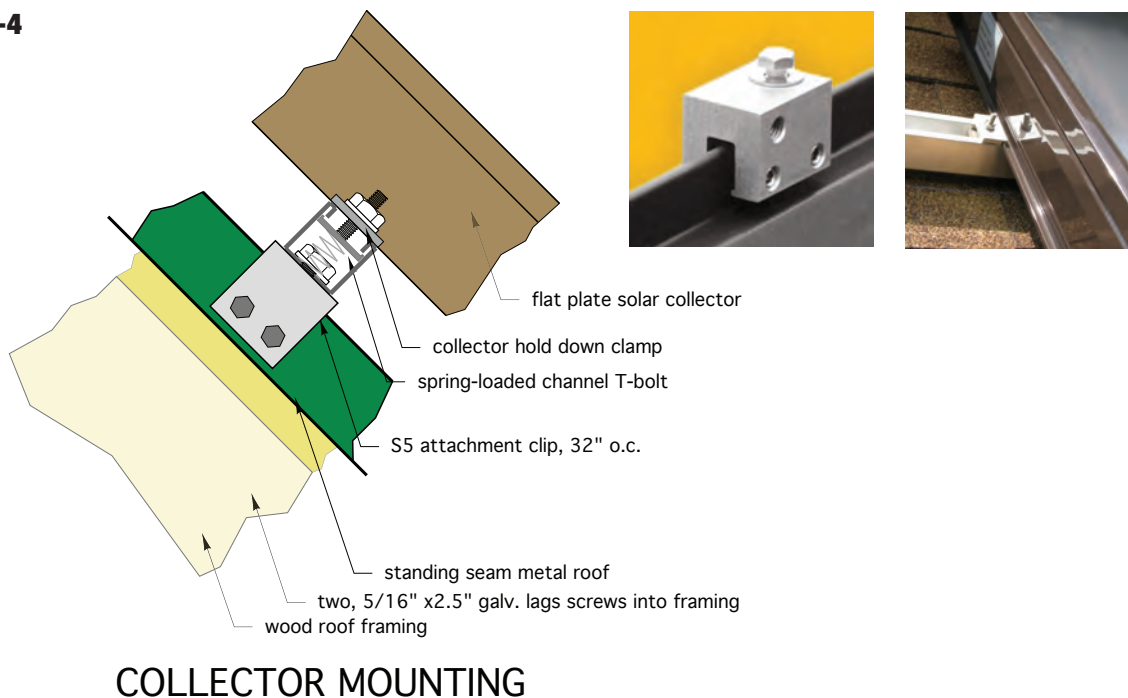
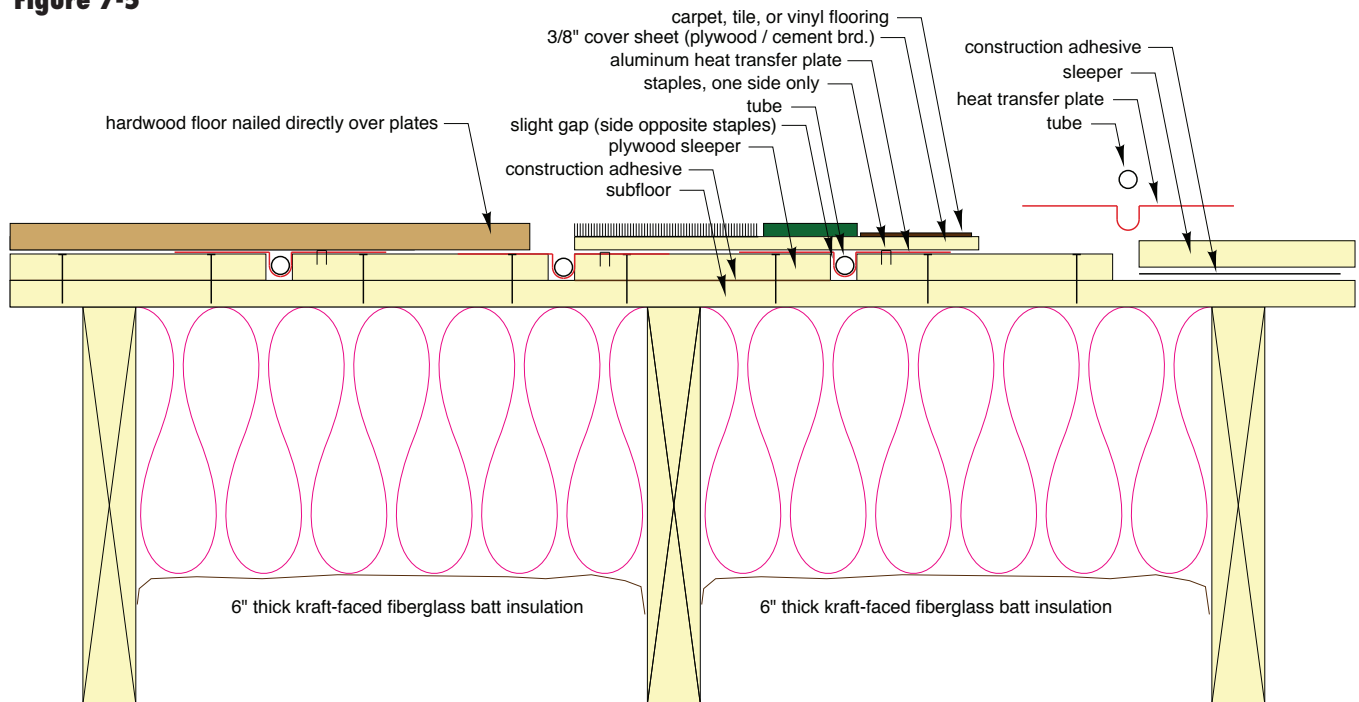

Figure 7-5



ABOVE FLOOR TUBE & PLATE RADIANT FLOOR PANEL

Designers should build a library of commonly specified details as they are developed. These details can then be quickly added to CAD drawings on future projects that use the same or very similar details.

PHOTOS OF INTENDED INSTALLATION DETAILS:

Many current generation CAD software products allow the import of files in several vector and bitmap file formats. One of the most common bitmap file formats is a JPEG file. JPEG files are commonly used for digital photos. They can also be used to store a "screen capture," which is the ability of modern operating systems to select an area of the current image displayed on the monitor, and capture just the pixels that form that selected area. Most CAD systems now support import of JPEG files. This allows the designer preparing the documentation to include one or more photos that are determined to be helpful in conveying how a specific detail should appear during and after it is installed. Figure 7-6 shows an example of how multiple photos showing different installation steps for an above-floor tube & plate radiant floor panel were inserted into a drawing along with a drawn detail.

SYSTEM SERVICE LOG

After a system is installed and initially commissioned, one might assume that no further documentation is necessary. However, every system is likely to require service over its life. During service visits, technicians may adjust controller setting or valves setting in an attempt to further refine the performance of the system based on feedback from building occupants. It's also possible that a given component in the system will fail and have to be replaced. Thus, the system may "evolve" over time in comparison to when it was first put into operation.

It is vitally important to maintain a log of all such adjustments, replacements or other service actions to the system. This log allows future service technicians who may not be familiar with the system to quickly assess what has been done to it, and thus plan what further actions may be necessary. Figure 7-7 shows one example of a service log.

The exact format of the system service log can vary; however, it should include the contact information for the system owner, as well as the following information at a minimum:

Figure 7-6

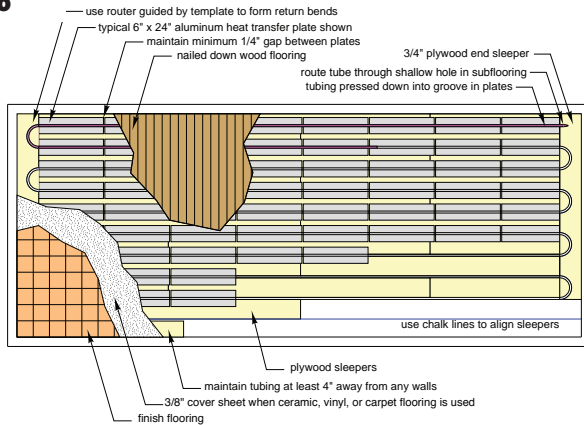

Photo of plywood sleepers glued and fastened to subfloor



Aluminum heat transfer plates installed over plywood sleepers prior to tubing and cover sheet.



Hardwood flooring installed over tube & plate system. Note nailing areas between plates

Figure 7-7

System installed for: Earl Williams System installation date: 7/12/2010 System installed by: All Season Heating & Air Conditioning Owner contact phone: 312-569-8798			
Date & person / company providing service or adjustment	Description of issue to be resolved	Description of work performed	Additional comments
9/10/2012 Bob Bowers Bob's Country Heating Service	Oil burner annual service	Replace oil burner nozzle with 0.6 gpm / 80"W Danfoss nozzle. Cleaned boiler and flue. Replaced oil filter. Measured 13% CO2 in breach, and 278 °F stack	Oil tank gauge at 10%. Oil tank label indicating tank is 25 years old. Advised owner to add oil and plan for tank replacement in near future
1/11/2013 Jack Jones Bob's Country Heating Service	No heat in master bedroom	replaced failed zone circulator, and reported systems	
9/25/2014 Jack Jones Bob's Country Heating Service	Oil burner annual service	Replace oil burner nozzle with 0.6 gpm / 80"W Danfoss nozzle. Cleaned boiler and flue. Replaced oil filter. Measured 12% CO2 in breach, and 285 °F stack	Advised owner to replace oil tank within 12 months
9/10/2015 Bob Bowers Bob's Country Heating Service	Replaced fuel oil tank due to age	Decommissioned and removed existing oil tank and replaced with new 275 gallon tank	Changed original 1.25" oil fill pipe to 2" pipe and added quick connect fitting.
2/20/2016 Kevin Koolade Two Guys Heating & Cooling	House temperature undershoots when outside temperature is cold	Changed reset ratio on boiler controller from 0.9 to 1.0. Also opened damper that was closed on master bedroom baseboard	

- The date when a service or adjustment was made
- The person and associated company who performed the service or adjustment
- A description of the issue to be resolved by the service or adjustment
- A description of exactly what was done
- A space for any additional comments

Any modern spreadsheet software can be used to quickly develop the system service log to the specific needs of the installer. This form can then be printed multiple times, and several copies inserted into the system binder and left on the project site. Service technicians can then fill in the columns at the end of a service visit.

A system service log can also be maintained as a spreadsheet file. Such a file should be periodically updated based on new information that was written into the system service log on the site.

There is also specialized software available that enables a service technician to enter the information using a laptop, tablet or smartphone while onsite. That information can then be quickly moved to a master service file maintained at the company doing service work.

SYSTEM BINDER

After creating good documentation, it's important to make it immediately available to those who may be servicing the system. A common approach is to prepare a system binder that contains the piping and electrical schematics, the description of operation, installation details and photos, and the system service log. It can also contain submittal sheets, installation manuals, or technical literature for the major components in the system. This documentation should be printed, ideally in color, and neatly placed in a 3-ring binder. The cover of the binder should provide the contact information for the installing contractor, as well as other heating professionals involved with the project. The binder should be housed in a clear plastic wall pocket, mounted in a location where it's readily visible to service personnel, as shown in figure 7-8

Having this information readily available allows the service technician to quickly gain an understanding of the system,

Figure 7-8



3-ring system binder (courtesy of Dan Davis Sales)

as well as interpret fault codes or other specific settings for the more complex system components, such as the boiler, heat pump, chiller or electronic controllers.

Given that much of the documentation will be created using software, it's also a good idea to create a digital archive of all documentation. This archive should include PDF files of the installation and operating (I/O) manual for all major equipment. These files are readily available from most manufacturer's websites. This digital information should be stored on site, on a CD or preferably on a USB thumb drive. It should also be stored off-site for quick reference when necessary.

Information that is handwritten into the system service log should be periodically scanned, digitally photographed, or manually entered into a spreadsheet version of the system service log, and included in the digital archive.

8. EXAMPLE SYSTEMS

This section gives examples of six hydronic systems that provide space heating, domestic water heating, and in one case, hydronic cooling. These systems range from simple to relatively complex in terms of the components involved. Each system is documented using a piping schematic, electrical schematic and description of operation.

Some of these systems require specialized embedded controllers for functions such as operating a motorized mixing valve, or maintaining the temperature of a buffer tank. A specific and appropriate controller is assumed in the documentation for these systems. However, in many cases, several other available controllers could be used, with only minor variations in the schematics and descriptions of operation.

EXAMPLE SYSTEM #1

Figure 8-1a shows the piping schematic for a relatively simple multiple zone hydronic “combi-system” that serves five zones of space heating and also provides domestic hot water using an indirect water heater. This system also uses a variable-speed pressure-regulated circulator that automatically adjusts speed based on the number of active zone valves.

The electrical schematic for this system is shown in figure 8-1b.

In this system, all coordination of the zone valves and system pump is handled by the circuitry and settings of the Caleffi ZVR106 multi-zone relay center. The boiler is managed by an outdoor reset controller, which is assumed to be external to the boiler.

Given that these controllers collectively provide all the operating logic for the system, it is not necessary to create a ladder diagram. However, it is still necessary to show how these controllers are powered and interconnected. The electrical schematic in figure 8-1b provides sufficient documentation to do this. It shows that both the boiler and multi-zone relay center are powered by a common circuit. It shows the main power switch (MS), the boiler service switch (BSS), and the low water cutoff (LWCO). It also shows the interconnection of the controllers, all thermostats, the DHW aquastat, the zone valves and the system circulator. All components are labeled so that they can be referenced in the piping schematic and description of operation.

DESCRIPTION OF OPERATION

SYSTEM POWER: The boiler and multi-zone relay center (ZVR106) are both supplied by a 120 VAC/15-amp dedicated circuit. The (ZVR106) receives power whenever the main switch (MS) is closed. The boiler receives power when the main switch (MS) and the boiler service switch (BSS) are closed, and the low water cutoff (LWCO) detects water present at its location in the system.

SPACE HEATING MODE: Upon a call for space heating from any of the five thermostats (T2-T6), the associated zone valves (ZV2- ZV6) are powered on by 24 VAC supplied from the (ZVR106). When any powered zone valve reaches its fully open position, an end switch within that valve’s actuator closes. This end switch closure signals the (ZVR106) that circulator (P1) can operate. The (ZVR106) passes 120 VAC to the system pump terminals to activate circulator (P1). Circulator (P1) is a variable-speed pressure-regulated circulator that has been set for the differential pressure required when all five space-heating zones are operating simultaneously. It will automatically adjust its speed as the number of active zone circuits changes. All calls for space heating from any of the five zone thermostats also causes the isolated (X X) contact on the (ZVR106) to close. The (X X) contact completes a circuit through the space-heating demand terminals on the boiler reset controller (BRC). This enables the boiler to fire under the control of the (BRC), which measures the outdoor temperature at sensor (S1), and uses this temperature along with its settings to calculate a target supply water temperature for the boiler. The (BRC) also measures the water temperature inside the boiler at sensor (S2) and compares it to the calculated

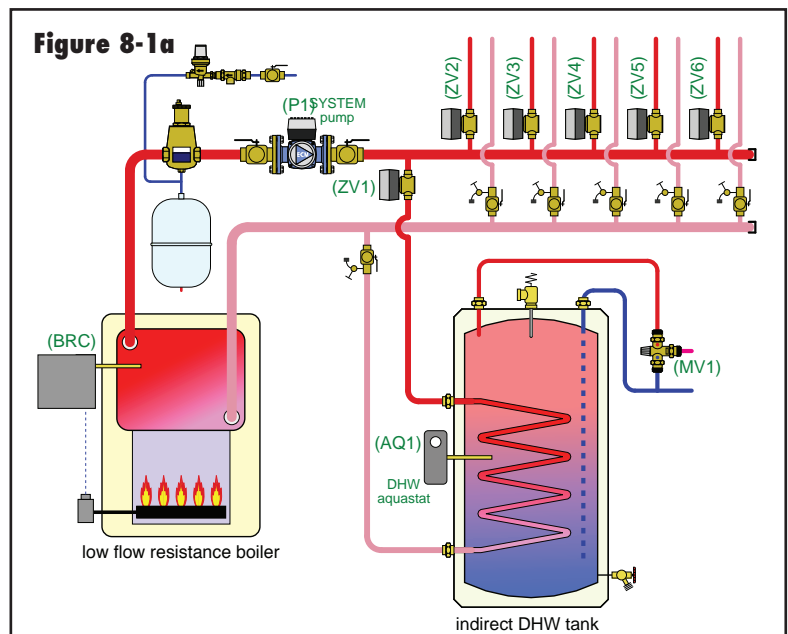
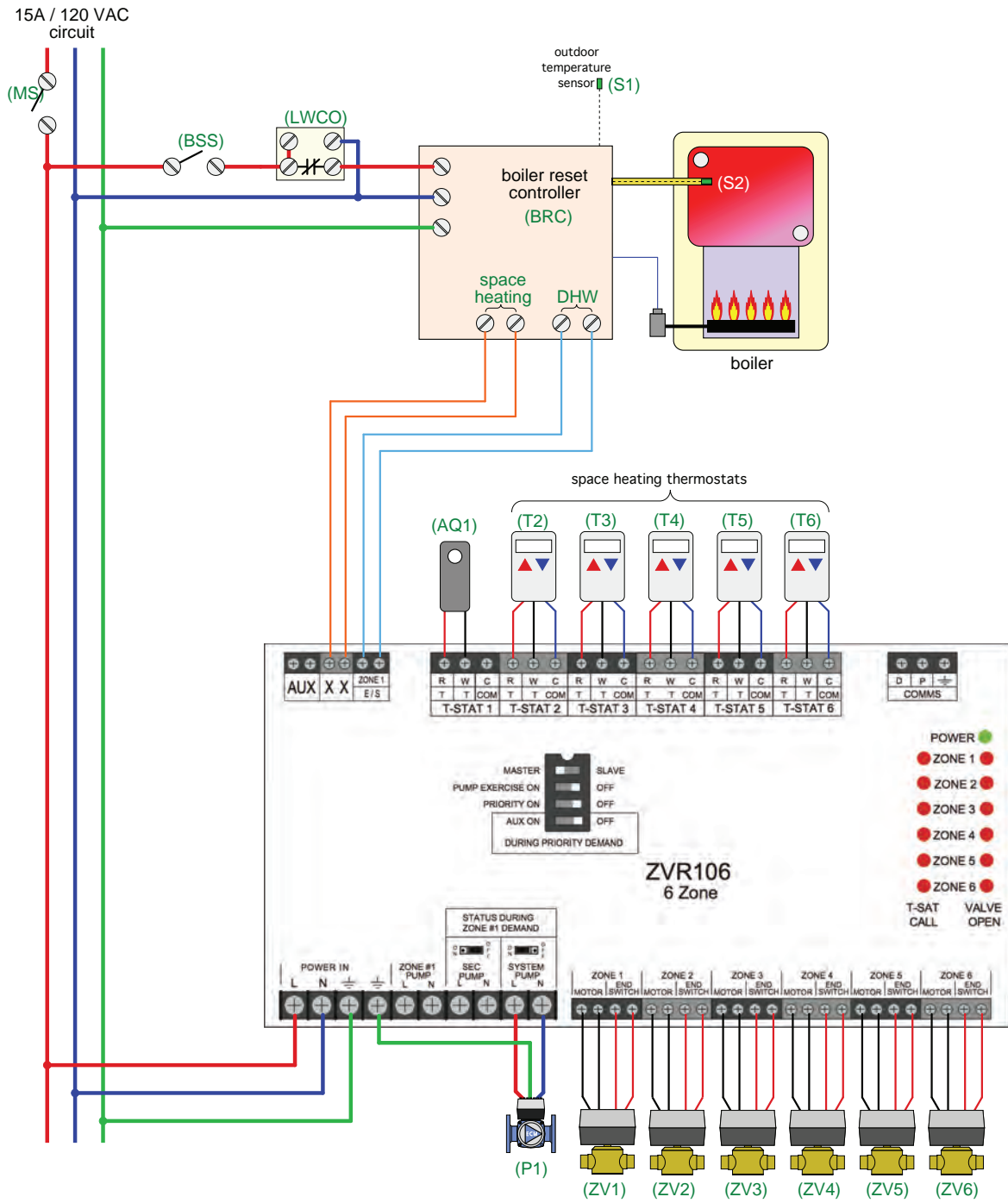

Figure 8-1b



target temperature. If the measured temperature is 5°F (adjustable) or more below the target temperature, the (BRC) turns on the boiler's burner. The burner continues to fire until the measured temperature of the water leaving the boiler climbs to 5°F (adjustable) or more above the current target temperature, or until all calls for heat from all space-heating thermostats (T2-T6) are satisfied.

DOMESTIC WATER HEATING MODE: A call for domestic water heating occurs when the normally open contact in the tank aquastat (AQ1) closes, based on the temperature setting of the aquastat. This closure is sensed by the (T-STAT 1) terminals in the multi-zone relay center (ZVR106). The (ZVR106) closes a set of isolated contacts (Zone 1 E/S), which completes a circuit

Figure 8-2a

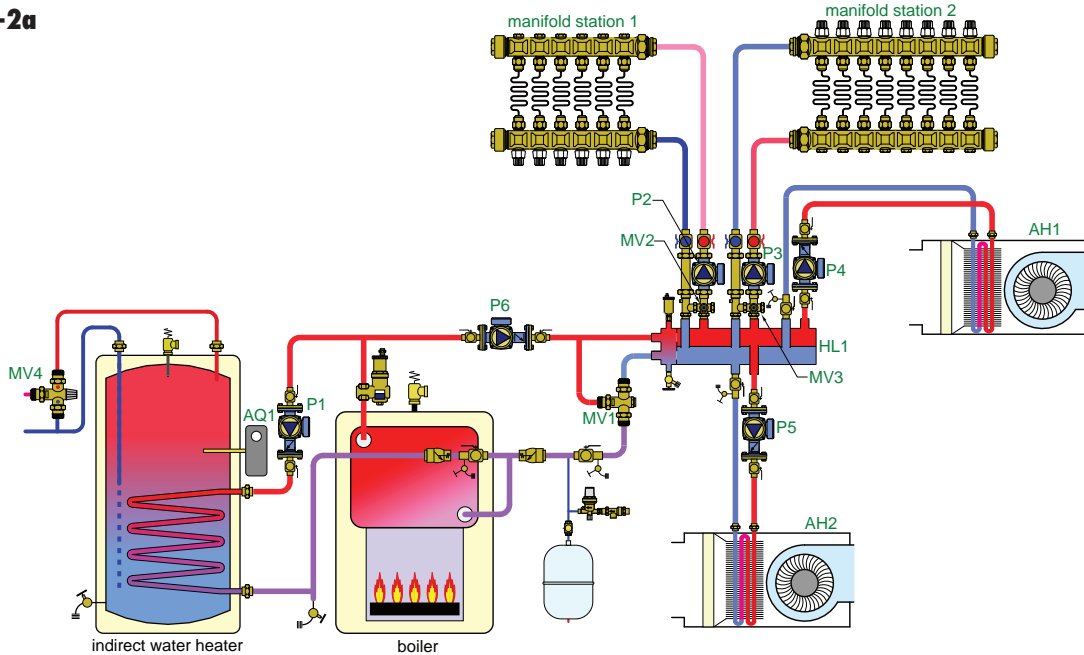

through the DHW demand terminals in the (BRC). The boiler is now enabled to operate in setpoint mode (e.g., targeting a fixed upper temperature limit regardless of outdoor temperature). Zone valve (ZV1) is powered on. When (ZV1) reaches its fully open position, its internal end switch closes. This is sensed by (ZRV106), which responds by turning on the system circulator (P1).

Domestic water heating is treated as a priority load. When a call for domestic water heating occurs, all other zones valves (ZV2-ZV6) are temporarily turned off for up to 60 minutes, assuming the tank aquastat (AQ1) continues to call for domestic water heating. If 60 minutes elapses and aquastat (AQ1) is still calling for domestic water heating, zone valve (ZV1) is turned off, and any space heating zones that are calling for heat are allowed to operate. This operating mode continues until all space-heating zone thermostats (T2-T6) that were calling for space heating when priority operation of (ZV1) began are satisfied. Only then can (ZV1) reopen, assuming (AQ1) is still calling for domestic water heating. The thermostatic mixing valve (MV1) is set to 120°F to limit domestic hot water delivery temperature.

CONTROLLER/VALVE SETTINGS:

- (BRC) high limit = 180°F (domestic water heating mode)
- (BRC) reset ratio = 1.5
- (BRC) min. supply temperature = 140°F
- (ZVR106) master/slave = master
- (ZVR106) pump exercise = OFF

- (ZVR106) priority = ON
- (ZVR106) Aux during priority = OFF
- (ZVR106) Status during zone #1 demand/secondary pump = OFF
- (ZVR106) Status during zone #1 demand/system pump = ON
- (AQ1) aquastat = 145°F
- (MV1) domestic hot water delivery temperature = 120°F

EXAMPLE SYSTEM #2

The system in figure 8-2a provides space heating using air handlers and radiant panels. The air handlers operate with a supply water temperature of 170°F at design load. The radiant panel manifold stations operate at supply water temperatures of 105°F and 110°F. The space-heating loads are all served through a Caleffi HydroLink. The low-temperature loads are supplied through Caleffi HydroMixer blocks with integrated thermostatic mixing valves. The conventional gas-fired boiler is protected against low-temperature return water by a high-flow capacity thermostatic mixing valve. Domestic water heating is treated as a priority load.

The electrical schematic for example system #2 is shown in figure 8-2b.

As was true with example system #1, all the operating logic for this system is contained within the multi-zone relay center (ZSR106) and the boiler reset controller (BRC). Therefore, the electrical schematic is shown in the same manner as for example system #1, showing power

Figure 8-2b

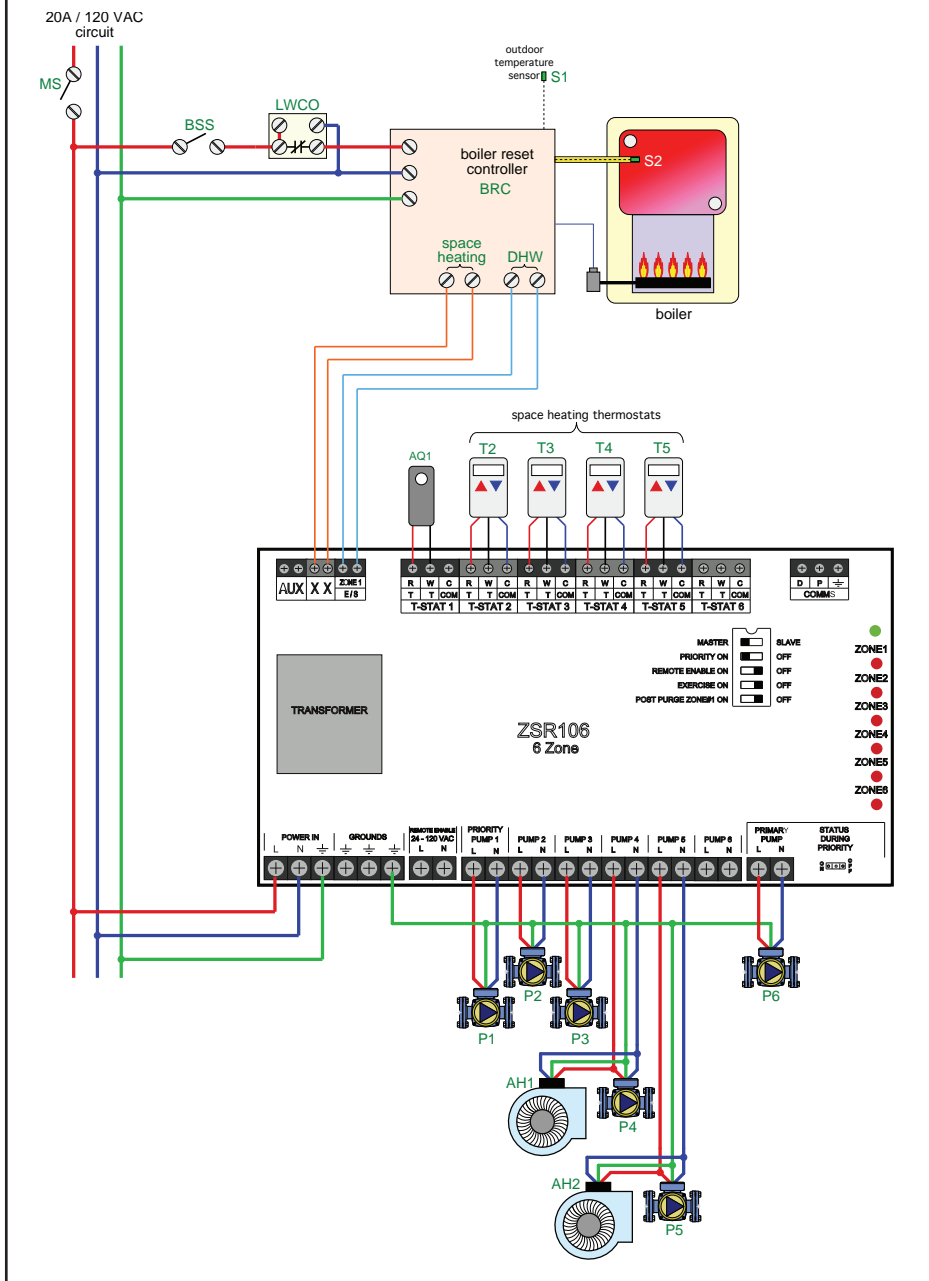

SPACE-HEATING MODE: Upon a call for space heating from any of the four thermostats (T2-T5), the associated zone circulators (P2-P5) are powered on by 120 VAC. The (ZSR106) also turns on circulator (P6) to create flow between the boiler and the HydroLink.

The lower temperature radiant panel loads are supplied through HydroMixer blocks attached to the HydroLink. A thermostatic mixing valve in each of the two HydroMixer blocks modulates to maintain a preset supply water temperature to each radiant panel manifold station.

The two air handlers are supplied directly from the HydroLink by circulators (P4) and (P5). The blower in air handler (AH1) is turned on by the same 120 VAC output that operates circulator (P4). The blower in air handler (AH2) is turned on by the same 120 VAC output that operates circulator (P5).

All calls for space heating from any of the four zone thermostats (T2-T5) also cause the isolated (X X) contacts on the (ZSR106) to close. The (X X) contact completes a circuit through the space-heating demand terminals on the boiler reset controller (BRC). This enables the boiler to fire under the control of the (BRC), which measures the outdoor temperature at sensor (S1), and uses this temperature along with its settings to calculate a target supply water temperature for the boiler. The (BRC) also measures the water temperature inside the boiler at sensor (S2) and compares it to the calculated target temperature. If the measured temperature is 5°F (adjustable) or more below the target temperature, the (BRC) turns on the boiler's burner. The burner continues to fire until the measured temperature of the water leaving the boiler climbs to 5°F (adjustable) or more above the target temperature, or until all calls for heat from the space-heating thermostats (T2-T5) are satisfied.

supply to both controllers, switches and interconnections between the controllers.

DESCRIPTION OF OPERATION

SYSTEM POWER: The boiler and multi-zone relay center (ZSR106) are both supplied by a 120 VAC/20-amp dedicated circuit. The (ZSR106) receives power whenever the main switch (MS) is closed. The boiler receives power when the main switch (MS) and boiler service switch (BSS) are closed, and the low water cutoff (LWCO) detects water present at its location in the system.



DOMESTIC WATER HEATING MODE: A call for domestic water heating occurs when the normally open contact in the tank aquastat (AQ1) closes, based on the aquastat's set temperature. This closure is sensed by the (T-STAT 1) terminals in the (ZSR106). The (ZSR106) closes a set of isolated contacts (Zone 1 E/S) which completes a circuit through the DHW demand terminals in the (BRC). The boiler is now enabled to operate in setpoint mode (e.g., targeting a fixed upper temperature limit regardless of outdoor temperature). Circulator (P1) is also turned on.

Domestic water heating is treated as a priority load. When a call for domestic water heating occurs, all other zones circulators (P2-P6) are temporarily turned off for up to 60 minutes, assuming the tank aquastat (AQ1) continues to call for domestic water heating. If 60 minutes elapse and aquastat (AQ1) is still calling for domestic water heating, circulator (P1) is turned off, and any zones that are currently calling for heat are allowed to operate. This mode continues until all space-heating thermostats (T2-T5) that were calling for heating when priority operation of (P1) began are satisfied. Only then can circulator (P1) restart, assuming (AQ1) is still calling for domestic water heating.

The thermostatic mixing valve (MV4) is set to 120°F to limit domestic hot water delivery temperature.

CONTROLLER/MIXING VALVE SETTINGS:

- (BRC) high limit = 180°F (domestic water heating mode)
- (BRC) reset ratio = 1.5
- (BRC) min. supply temperature = 140°F
- (ZSR106) master/slave = master
- (ZSR106) priority = ON
- (ZSR106) remote enable = OFF
- (ZSR106) exercise = ON
- (ZSR106) post purge zone #1 = OFF
- (AQ1) aquastat = 145°F, differential = 10°F
- (MV1) boiler inlet temperature protection setting = 130°F
- (MV2) supply water to manifold station 1 setting = 105°F
- (MV3) supply water to manifold station 2 = 115°F
- (MV4) DHW anti-scald setting = 120°F

EXAMPLE SYSTEM #3

The system shown in figure 8-3a is supplied by a mod/con boiler, which can be called to operate in either space-

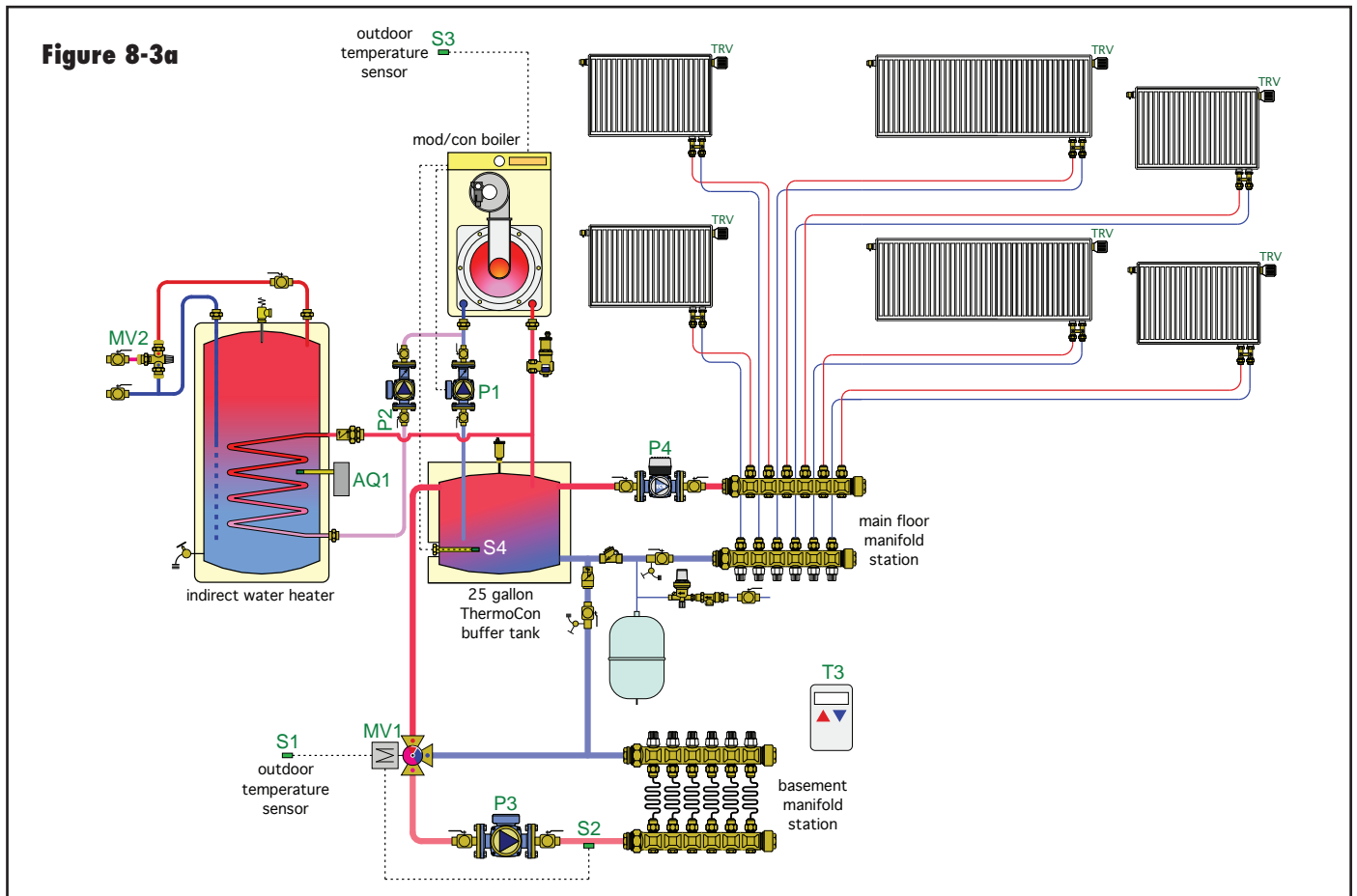
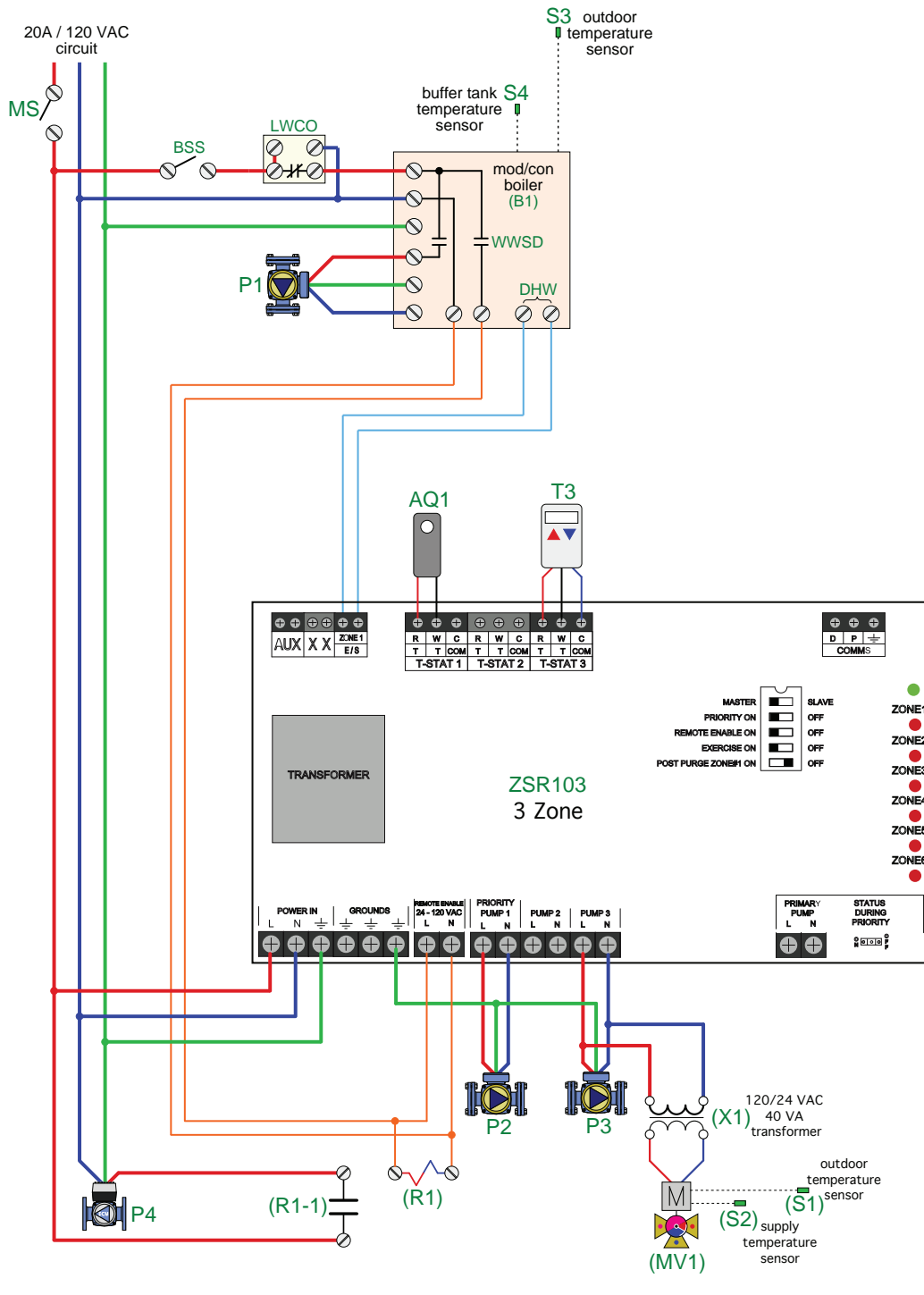

Figure 8-3b



heating mode (in which it uses its own internal reset control logic), or setpoint temperature mode, where it seeks a fixed high limit temperature. Space heating is supplied to the main floor area of the building by panel radiators, and to the basement by radiant floor panels. The latter requires a significant lower supply water temperature, which is created by a motorized mixing valve with a combined

controller/actuator. Domestic hot water is supplied as a priority load by an indirect water heater.

The electrical schematic for this system is shown in figure 8-3b.

DESCRIPTION OF OPERATION

SYSTEM POWER: The boiler and multi-zone relay center (ZSR103) are both supplied by a 120 VAC/20-amp dedicated circuit. The (ZSR103) receives power whenever the main switch (MS) is closed. The boiler receives power when the main switch (MS) and boiler service switch (BSS) are closed, and the low water cutoff (LWCO) detects water present at its location in the system.

SPACE-HEATING MODE: When power is available to it, the mod/con boiler continuously measures outside temperature at sensor (S3). When the outdoor temperature is below the warm weather shutdown (WWSD) setting, the boiler closes an internal contact to send 120 VAC to the remote enable terminals on the (ZSR103). With remote enable powered, the (ZSR103) can operate the space-heating zones as necessary. 120 VAC from the remote enable circuit is also sent to relay coil (R1). Relay contact (R1-1) closes to provide 120 VAC to circulator (P4). The boiler fires its burner and turns on circulator (P1). The boiler monitors the temperature of the water in the buffer tank at sensor (S4). It continues to fire until the temperature at sensor (S4) in the buffer tank is slightly above a target temperature the boiler has calculated based on its internal reset logic and settings, as well as the current outdoor temperature.

PANEL RADIATOR HEATING: This system is designed so that areas of the building served by the panel radiators will automatically have heated water available to those panel radiators whenever the boiler is not in warm weather shutdown mode. Circulator (P4) is on whenever the boiler is not in warm weather shutdown. (P4) is a variable-speed pressure-regulated circulator that has been set to the differential pressure required when the thermostatic radiator valves (TRV) on all the panel radiators are fully open. Heated water will flow from the buffer tank to each panel radiator on which the (TRV) is partially or fully open. The speed of circulator (P4) will automatically increase or decrease based on maintaining a constant preset differential pressure, regardless of how many thermostatic radiator valves are partially or fully open. If all thermostatic radiator valves are fully closed, circulator (P4) will reduce speed to a minimum "sleep mode" level, and await the opening of one or more thermostatic radiator valves, at which time it will increase speed as necessary.

BASEMENT HEATING: When thermostat (T3) calls for heating, the (ZSR103) controller turns on circulator (P3) and transformer (X1). Transformer (X1) supplies 24 VAC to the combined controller/actuator of the 3-way motorized mixing valve (MV1). When it is powered on by the 24 VAC, this controller/actuator measures outdoor temperature

at sensor (S1), and uses this temperature along with its settings to calculate a target supply water temperature for the basement floor-heating circuits. It measures the temperature of the supply water at sensor (S2) and compares it to the calculated target temperature. If the measured temperature is below the target temperature, the actuator/controller rotates the shaft of mixing valve (MV1) to increase supply water temperature, and vice versa. The boiler will respond to the temperature change at sensor (S4) in the buffer tank, and fire as necessary to provide ample heated water to mixing valve (MV1). When thermostat (T3) is satisfied, circulator (P3) and the motorized mixing valve (MV1) are turned off.

DOMESTIC WATER HEATING MODE: A call for domestic water heating occurs when the normally open contact in the tank aquastat (AQ1) closes, based on its setting and current tank temperature. This closure is sensed by the (T-STAT 1) terminals in the multi-zone relay center (ZSR103). The (ZSR103) closes a set of isolated contacts (Zone 1 E/S), which completes a circuit through the DHW demand terminals in the boiler, enabling it to operate in setpoint mode (e.g., targeting a fixed upper temperature limit regardless of outdoor temperature). Circulator (P2) is powered on.

Domestic water heating is treated as a priority load. When a call for domestic water heating occurs, circulator (P1) is turned off by the boiler, and circulator (P3) is temporarily turned off by the (ZSR103) for up to 60 minutes, assuming the tank aquastat (AQ1) continues to call for domestic water heating. Circulator (P4) remains on to deliver heat from the buffer tank to the panel radiators while priority domestic water heating takes place. If 60 minutes elapse and aquastat (AQ1) is still calling for domestic water heating, circulator (P2) is turned off until zone thermostat (T3) is satisfied. Only then can circulator (P2) restart, assuming (AQ1) is still calling for domestic water heating. The thermostatic mixing valve (MV2) is set to 120°F to limit domestic hot water delivery temperature.

CONTROLLER/MIXING VALVE SETTINGS:

Boiler high limit (during setpoint operation) = 180°F
Boiler reset ratio (during space heating) = 1.0
Boiler warm weather shutdown = 55°F (outdoor temperature)
Boiler minimum water temperature (during space heating) = 100°F at WWSD = 55°F
(ZSR103) master/slave = master
(ZSR103) priority = ON
(ZSR103) remote enable = ON

Figure 8-4a

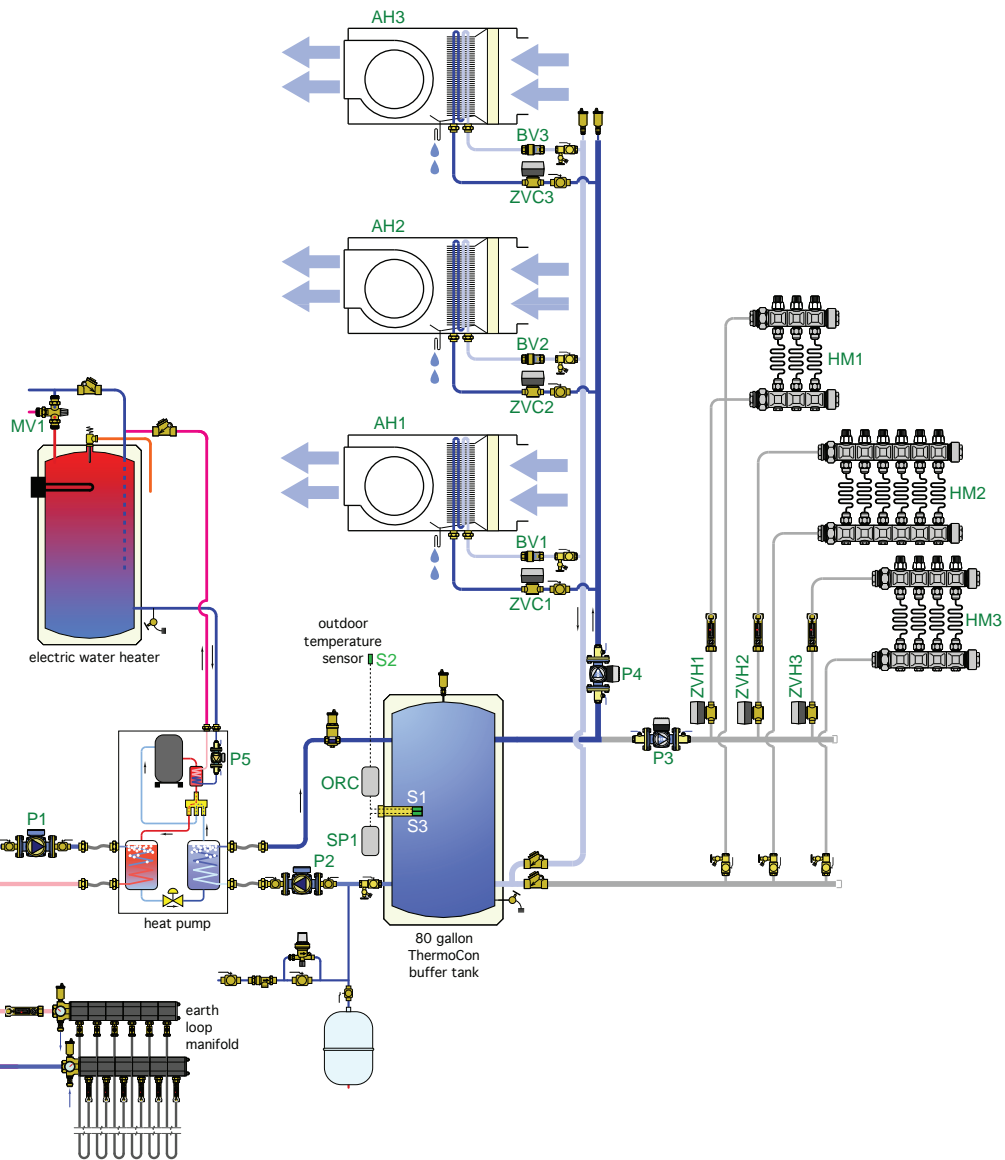

- (ZSR103) exercise = ON
- (ZSR103) post purge zone #1 = OFF
- (AQ1) aquastat = 140°F
- (MV1) reset ratio = 0.5
- (MV1) maximum water temperature = 110°F
- (MV1) minimum water temperature = 75°F at WWSD = 55°F
- (MV2) setting = 120°F

EXAMPLE SYSTEM #4

The system in figure 8-4a uses a water-to-water heat pump supplied from a closed earth loop to supply heating and cooling to three independently controlled zones. It also supplies domestic water preheating whenever the

heat pump is operating. Supplemental domestic water heating is provided by an electric heating element in the upper portion of the DHW tank. Space heating is supplied by radiant floor circuits fed through three manifold stations that are each controlled by a zone valve. Cooling is provided by three chilled-water air handlers equipped with condensate drip pans and supplied through zone valves. The buffer tank is used in both heating and cooling modes to prevent the heat pump from short cycling.

PIPING SCHEMATIC

The system in figure 8-4a is depicted in cooling mode operation (e.g., with the space heating piping and manifold stations on the schematic shown in gray).



Figure 8-4b

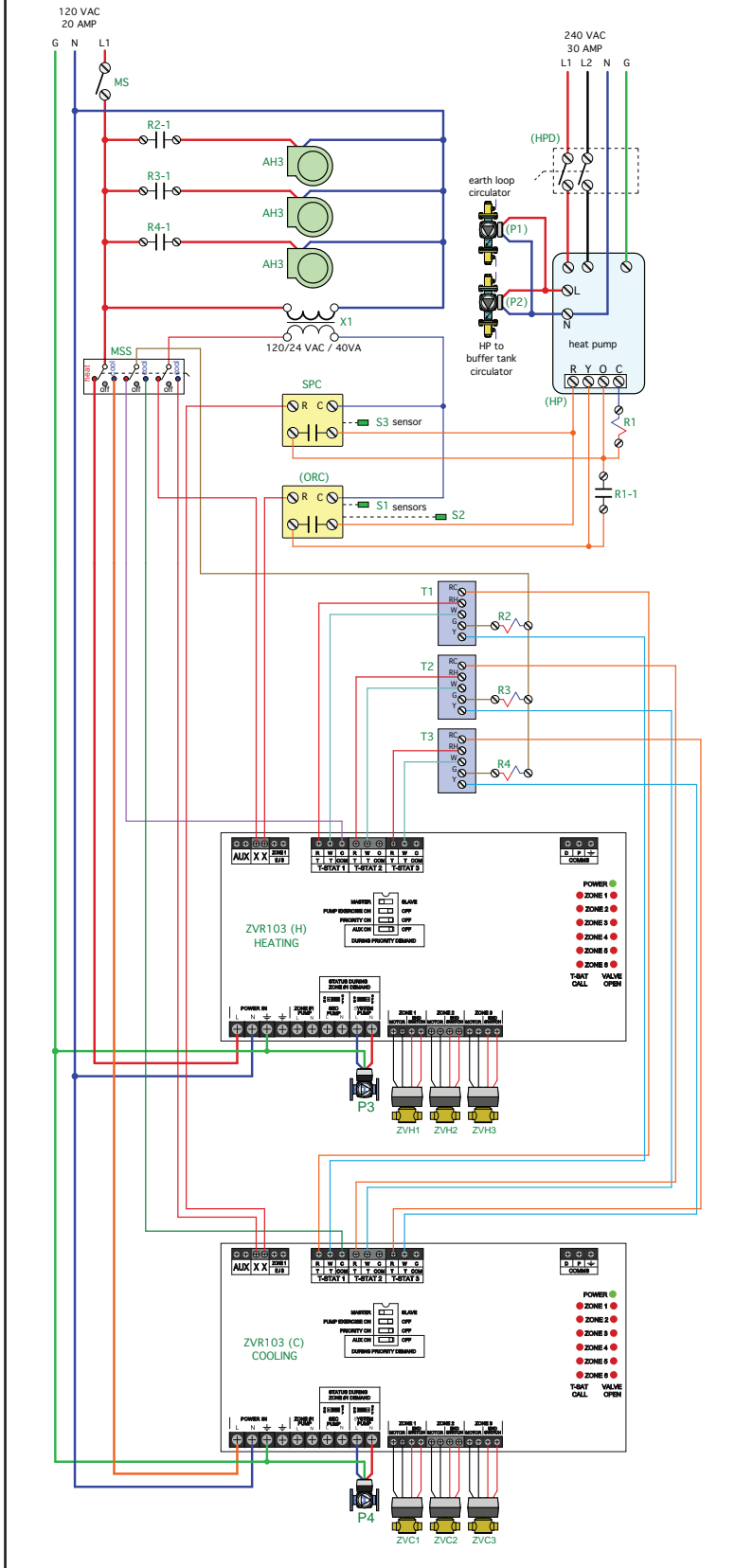

Although the air handlers are configured for chilled-water cooling, the owner has asked for the ability to operate each air handler in “fan-only” mode, while the system is in either heating or cooling mode. This allows heat from an area where a wood stove is located to be better distributed throughout the house.

Each of the three thermostats has the capability to switch between heating and cooling control. However, this system cannot provide *simultaneous* heating and cooling. It must be set to either heating or cooling mode by a mode selection switch (MSS). This system is not recommended for climates where heating may be needed in the morning, with cooling needed later that same day.

In heating mode, the heat pump operates to maintain temperature of the buffer tank based on outdoor reset control. This reduces the operating temperature of the heat pump’s condenser during part load conditions, which improves its coefficient of performance.

During cooling mode, the heat pump operates to maintain the water temperature in the buffer tank between 45 and 60°F.

The heating or cooling of the buffer tank only takes place when there is a demand for heating or cooling from one or more of the three thermostats.

ELECTRICAL SCHEMATIC

The electrical schematic for the system is shown in figure 8-4b. It is a hybrid drawing that uses some elements of ladder diagrams, as well as point-to-point wiring between the multi-zone relay centers and other controllers.

DESCRIPTION OF OPERATION

SYSTEM POWER: *The control system receives power from a 120 VAC/20-amp circuit whenever the main switch (MS) is closed. This circuit powers all controls, circulators (P3) and (P4), all three air handlers, thermostats and relays. The heat pump receives power from a dedicated 240/120 VAC/30-amp circuit whenever the heat pump disconnect (HPD) switch is closed. The heat pump circuit also powers circulators (P1) and (P2).*

MODE SELECTION: *The mode selection switch (MSS) is a 3-pole double throw manual switch. It must be set to "HEAT" for heating mode operation, or "COOL" for cooling mode operation. If the (MSS) is set to OFF, the system will not operate in either heating or cooling mode, and all controllers are powered down.*

SPACE-HEATING MODE: *The mode selection switch (MSS) must be set for heating. This passes 120 VAC to the [ZVR103(H)] multi-zone relay center. It also passes 24 VAC from transformer (X1) to the (X X) contacts on the [ZVR103(H)] controller. 24 VAC is provided from the [ZVR103(H)] transformer to the (RH) terminals on all three thermostats (T1, T2, T3). When any of these thermostats call for heating, 24 VAC is passed to the (W) terminal of the thermostat. The 24 VAC is then passed back to the thermostat input terminals on the [(ZVR103(H)] controller, and the associated zone valve (ZVH1, ZVH2, ZVH3) is powered on. When the powered zone valves reach their fully open position, their internal end switch closes, which signals the [ZVR103(H)] to turn on circulator (P3). Circulator (P3) is a variable-speed pressure-regulated circulator. It is set to the differential pressure required when all three heating zones are operating simultaneously. Circulator (P3) will automatically adjust its speed as the three heating zone valves open and close. The (X X) contact in the [ZVR103(H)] controller also closes when any thermostat calls for heating. This passes 24 VAC from transformer (X1) to the outdoor reset controller (ORC). The (ORC) measures the current outdoor temperature at sensor (S2), and uses this temperature along with its settings to calculate the target water temperature for the buffer tank, measured at sensor (S1). If the measured temperature at (S1) is 5°F or more below the calculated target temperature, the (ORC) closes its contacts, which completes a circuit between the (R) and (Y) terminals of the heat pump, turning it on in heating mode. The heat pump passes 120 VAC to circulators (P1) and (P2) to provide flow through the earth loop, as well as between the heat pump and the buffer tank. Provided that a heating call remains active from one or more of the thermostats (T1, T2, T3), the heat pump continues to operate until the temperature at sensor (S1) is 5°F above the target temperature, at which point the heat pump turns off, and so do circulators (P1) and (P2).*

AIR HANDLER OPERATION (DURING HEATING MODE): *The air handlers are primarily for cooling. However, they can be used to circulate air through the building in either heating or cooling mode. If the air handlers are operated when the mode selection switch (MSS) is set to heating, there will be no heated or cooled water passing through their coils. In heating mode, they are only for air circulation.*

If the mode selection switch is set for heating, and the fan selector switch on any thermostat is set to "ON," 24 VAC is present on the (G) terminal of that thermostat. This 24 VAC is passed to the coil of a relay (R2, R3, R4), depending on which thermostat is set to "ON" fan. The associated relay contact (R2-1, R3-1, or R4-1) closes to pass 120 VAC to the blower of the associated air handler. If the thermostat is set for "AUTO" fan, the blower will only run when the thermostat is calling for heat. If the thermostat fan switch is set to "ON," the blower in the associated air handler will run continuously. The three relay coils (R2, R3, R4) are powered by the transformer in the [ZVR103(H)] controller. The common side of the 24 VAC circuit through relay coils (R2, R3, R4) passes through the mode selection switch (MSS) to the 24 VAC common terminal on the [ZVR103(H)] controller.

COOLING MODE: *The mode selection switch (MSS) must be set for cooling. This passes 120 VAC to the [ZVR103(C)] multi-zone relay center controller. It also passes 24 VAC from transformer (X1) to the (X X) contacts on the [ZVR103(C)] controller. It also passes 24 VAC from the [ZVR103(C)] controller transformer to the (RC) terminals on all three thermostats (T1, T2, T3). When any of the thermostats call for cooling, the associated zone valve (ZVC1, ZVC2, ZVC3) is powered on by the [ZVR103(C)] controller. When the zone valves reach their fully open position, their internal end switch closes, which signals the [ZVR103(C)] to turn on circulator (P4). Circulator (P4) is a variable-speed pressure-regulated circulator. It should be set to the differential pressure required when all three cooling zones are operating simultaneously. Circulator (P4) will automatically adjust its speed as the three cooling zone valves open and close. The (X X) contact in the [ZVR103(C)] controller also closes when any thermostat calls for cooling. This passes 24 VAC from transformer (X1) to the setpoint controller (SPC). The (SPC) is set to close its contacts if the temperature at sensor (S3) in the buffer tank reaches or exceeds 60°F. Its contacts open if the temperature at sensor (S3) drops to or below 45°F. A closed contact in (SPC) passes 24 VAC to the coil of relay (R1) and terminal (O) of the heat pump. Relay contact (R1-1) closes to pass 24 VAC from the (R) terminal of the heat pump to the (Y) terminal of the heat pump. This turns on the heat pump in cooling mode. The heat pump passes 120 VAC to circulators (P1) and (P2) to provide flow through the earth loop, as well as between the heat pump and the buffer tank.*

AIR HANDLER OPERATION (DURING COOLING MODE): *If the mode selection switch is set for cooling, and the fan switch on any thermostat is set to "ON," 24 VAC is present on the (G) terminal of the thermostat. This 24 VAC is passed to the coil of a relay (R2, R3, R4), depending on which thermostat has the fan switch set to ON. The*

associated relay contact (R2-1, R3-1, or R4-1) closes to pass 120 VAC to the blower of the associated air handler. If the fan switch on the thermostat is set to "AUTO" mode, the blowers will only run when the associated thermostat is calling for cooling. If the fan switch on the thermostat is set to "ON," the blower in the associated air handler will run continuously. The three relay coils (R2, R3, R4) are powered by the transformer in the [ZVR103(C)] controller. The common side of the 24 VAC circuit through relay coils (R2, R3, R4) passes through the mode selection switch (MSS) to the common terminal on the [ZVR103(C)] controller.

DOMESTIC WATER HEATING MODE: The heat pump contains a desuperheater heat exchanger and small bronze circulator (P5), which runs whenever the heat pump is operating in either heating or cooling mode. Heat from the hot refrigerant gas leaving the compressor passes through the desuperheater and transfers heat to domestic water drawn from the lower portion of the electric water heater. This water absorbs heat from the desuperheater and flows back to the dip tube connection on the water heater. This provides a portion of the domestic water heating load. The electric element in the upper portion of the tank provides supplementary water heating. An anti-scald thermostatic mixing valve (MV1) is set to 120°F to limit the hot water temperature delivered to the plumbing system.

CONTROLLER/MIXING VALVE SETTINGS:

ZVR103 (H) master/slave = MASTER
ZVR103 (H) pump exercise = OFF
ZVR103 (H) priority = OFF
ZVR103 (H) Aux on during priority = OFF

ZVR103 (C) master/slave = MASTER
ZVR103 (C) pump exercise = OFF
ZVR103 (C) priority = OFF
ZVR103 (C) Aux on during priority = OFF

ORC reset ratio = 0.5
ORC minimum supply = 85°F
ORC max supply = 110°F

SPC contacts close = 60°F
SPC contacts open = 45°F

MV1 setting = 120°F
DHW tank thermostat setting = 135°F

EXAMPLE SYSTEM #5

The system shown in figure 8-5a combines a 2-stage air-to-water heat pump with an auxiliary mod/con boiler. It provides zoned space heating through individually controlled panel radiators. It provides cooling through a single chilled-water air handler. It also provides domestic hot water, using heat from both the heat pump and the auxiliary boiler.

To protect the heat pump, as well as much of the remaining portion of the system, from freezing, all space-heating and cooling portions of the system operate with a 30% solution of inhibited propylene glycol antifreeze. This eliminates the need for a heat exchanger between the outdoor heat pump and the remainder of the system.

Figure 8-5b shows the electrical wiring schematic for the system.

DESCRIPTION OF OPERATION

SYSTEM POWER: Electrical power to operate the controllers; circulators (P2), (P3), (P4) and (P5); and the auxiliary boiler is provided by a 120 VAC/20-amp dedicated circuit. Power to operate the air-to-water heat pump and circulator (P1) is provided by a 240/120 VAC/40-amp dedicated circuit.

SPACE-HEATING MODE: The main switch (MS) and heat pump disconnect switch (HPDS) must be closed, and the mode selection switch (MSS) must be set to heat. This passes 24 VAC to the RH terminal of the master thermostat (T1). When the master thermostat (T1) calls for heating, 24 VAC is passed to the (W) terminal of the thermostat, which energizes the coil of relay (RH2). Relay contact (RH2-1) closes, passing 120 VAC to circulator (P2). Circulator (P2) is a variable-speed pressure-regulated circulator set for constant differential pressure mode. It automatically adjusts speed as the thermostatic radiator valves on the panel radiators open, close or modulate flow through their respective panels.

When the main switch (MS) is closed, 24 VAC is also passed to the R terminal of the 2-stage setpoint controller (SPH), turning it on. The (SPH) controller monitors the temperature of sensor (S1) in the upper portion of the buffer tank. When this temperature drops to 115°F, the (SPH) controller closes its stage 1 contacts. This passes 24 VAC to relay coil (RH1), and to diverter valve (DV1). Relay contact (RH1-1) closes between terminals 43 and 44 on the heat pump. Relay contact (RH1-2 NC) opens between terminals 5 and 6 on the heat pump. After a short time delay, the heat pump passes 120 VAC to circulator

Figure 8-5a

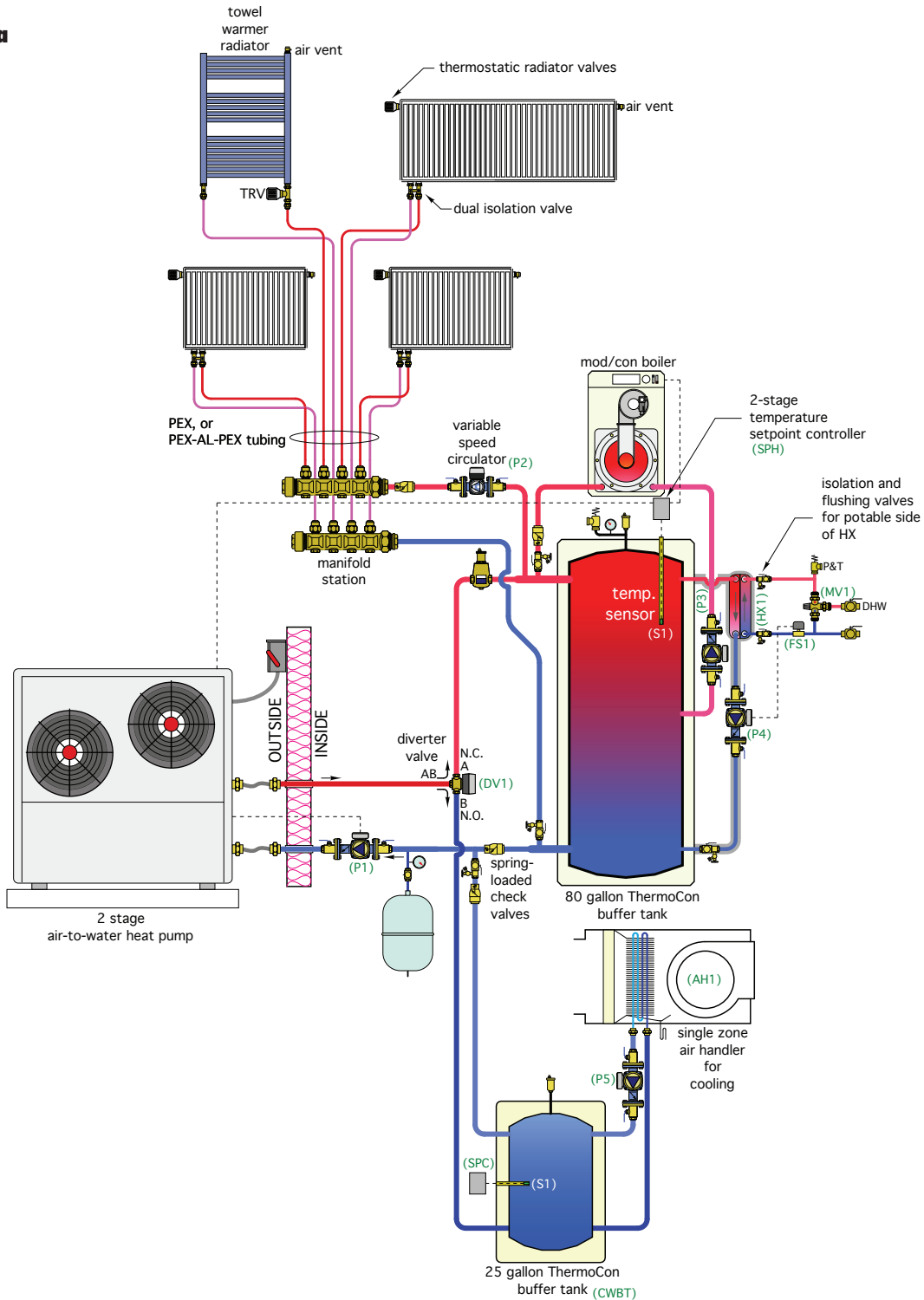

(P1), and turns on in heating mode. The heat pump's internal controls determine if one or both stages are active. Diverter valve (DV1) directs the flow of heated antifreeze solution from the heat pump to the upper header of the buffer tank (e.g., flow passes from the AB port to the A port

of DV1). The heat pump and these associated devices continue to operate as described until sensor (S1) climbs to 125°F, or if the master thermostat (T1) stops calling for heat. Note, the heat pump's internal controller must be set to a high limit temperature of at least 130°F.

Figure 8-5b

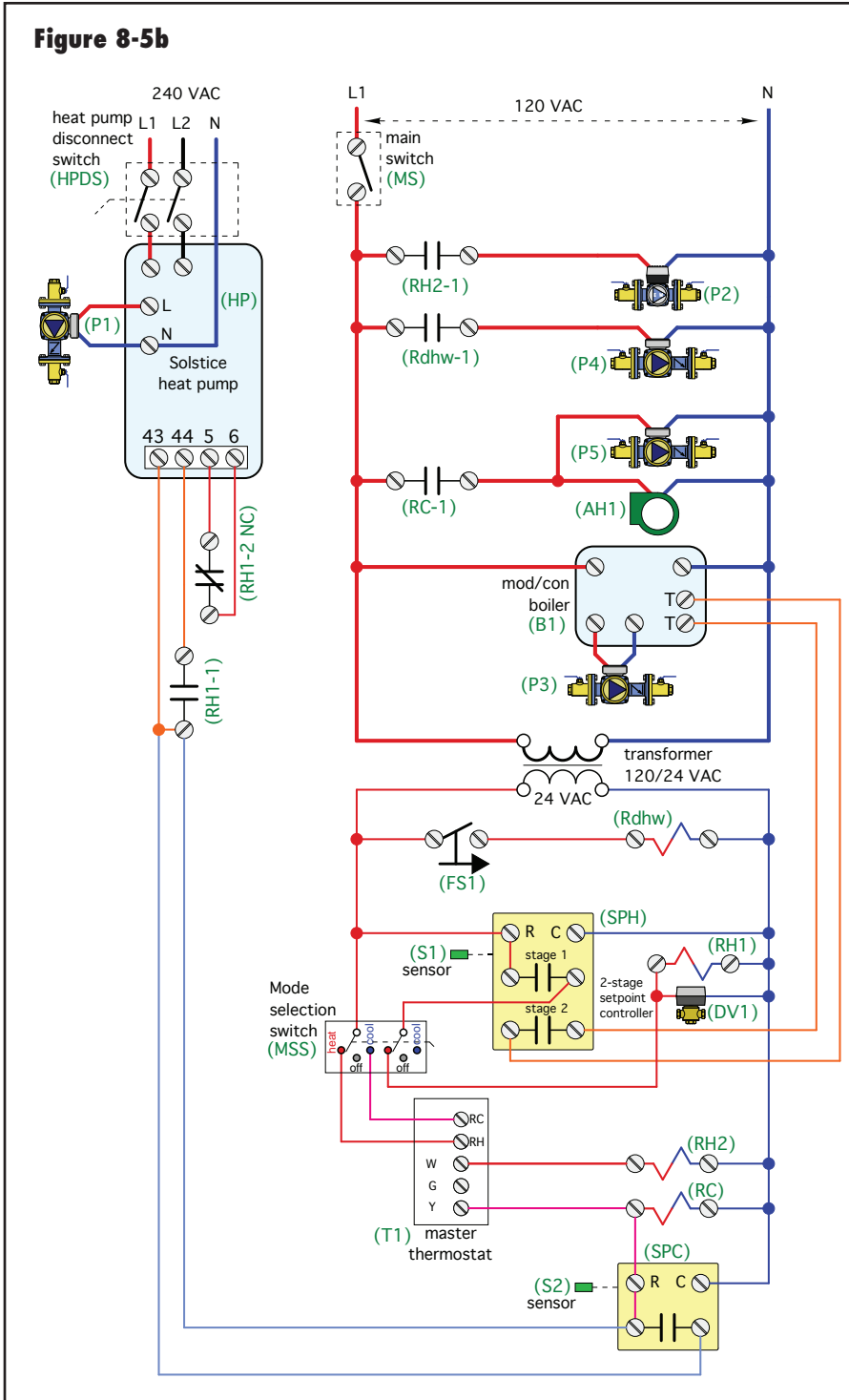

COOLING MODE: The main switch (MS) and heat pump disconnect switch (HPDS) must be closed, and the mode selection switch (MSS) must be set to cool. This passes 24 VAC to the RC terminal of the master thermostat. If the master thermostat is set for cooling, and calls for cooling, 24 VAC is passed to its (Y) terminal. From the (Y) terminal, 24 VAC energizes the coil of relay (RC) and the cooling setpoint controller (SPC). A normally open set of contacts (RC-1) close to pass 120 VAC to the air handler (AH1) turning it and circulator (P5) on. If the temperature at sensor (S2) in the chilled-water buffer tank is 60°F or higher, the contacts in the (SPC) close to complete a circuit across terminals (43) and (44) in the heat pump. After a short time delay, circulator (P1) turns on, and the heat pump operates in cooling mode. The heat pump's internal controls determine if one or both stages are active. This continues until either the master thermostat (T1) reaches its cooling setpoint, or until sensor (S2) reaches 45°F, at which point the (SPC) controller turns off the heat pump. If sensor (S2) reaches 45°F, and master thermostat (T1) is still calling for cooling, the air handler (AH1) and circulator (P5) remain on.

DOMESTIC WATER HEATING MODE: Whenever there is a demand for domestic hot water of 0.6 gpm or more, flow switch (FS1) closes. This passes 24 VAC to energize the coil of relay (Rdhw). Contact (Rdhw-1) closes to pass 120 VAC to circulator (P4). Heated fluid flows from the upper portion of the buffer tank through the primary side of heat exchanger (HX), and transfers heat to the cold domestic water flowing through the secondary side of the heat exchanger (HX). When the demand for domestic hot water

drops to 0.4 gpm or less, flow switch (FS1) opens. This turns off relay (Rdhw) and circulator (P4). All domestic hot water leaving the system passes through a thermostatic mixing valve (MV1) to limit the water temperature to the distribution system.

If the temperature at sensor (S1) drops to 110°F, the stage 2 contacts in the (SPH) controller close. This completes a circuit across the (T T) terminals in the auxiliary boiler, enabling it to turn on circulator (P3) and fire its burner. The boiler and circulator (P3) remain on until sensor (S1) reaches a temperature of 130°F, at which point the boiler is turned off.

When the mode selection switch is set to cooling, the stage 1 contacts of the (SPH) controller do not provide any control action. However, the stage 2 contacts of the (SPH) controller still operate the auxiliary boiler to maintain the temperature at sensor (S1) in the buffer tank between 110 and 130°F. This provides heat for domestic water when the heat pump is in cooling mode.

- SPH stage 2 contacts close at 110°F, open at 130°F
- Heat pump internal high limit (heating mode) = 130°F
- Heat pump internal high limit differential (heat mode) = 10°F
- Heat pump internal low limit (cooling mode) = 40°F
- Heat pump internal low limit differential (cooling mode) = 15°F
- Thermostat (T1) setting = 70°F heating, 75°F cooling
- Thermostat (T1) fan setting = ON
- TRV initial settings = 3
- Mixing valve (MV1) = 115°F

CONTROLLER/MIXING VALVE SETTINGS:
 SPH, stage 1 contacts close at 115°F, open at 125°F

Figure 8-6a

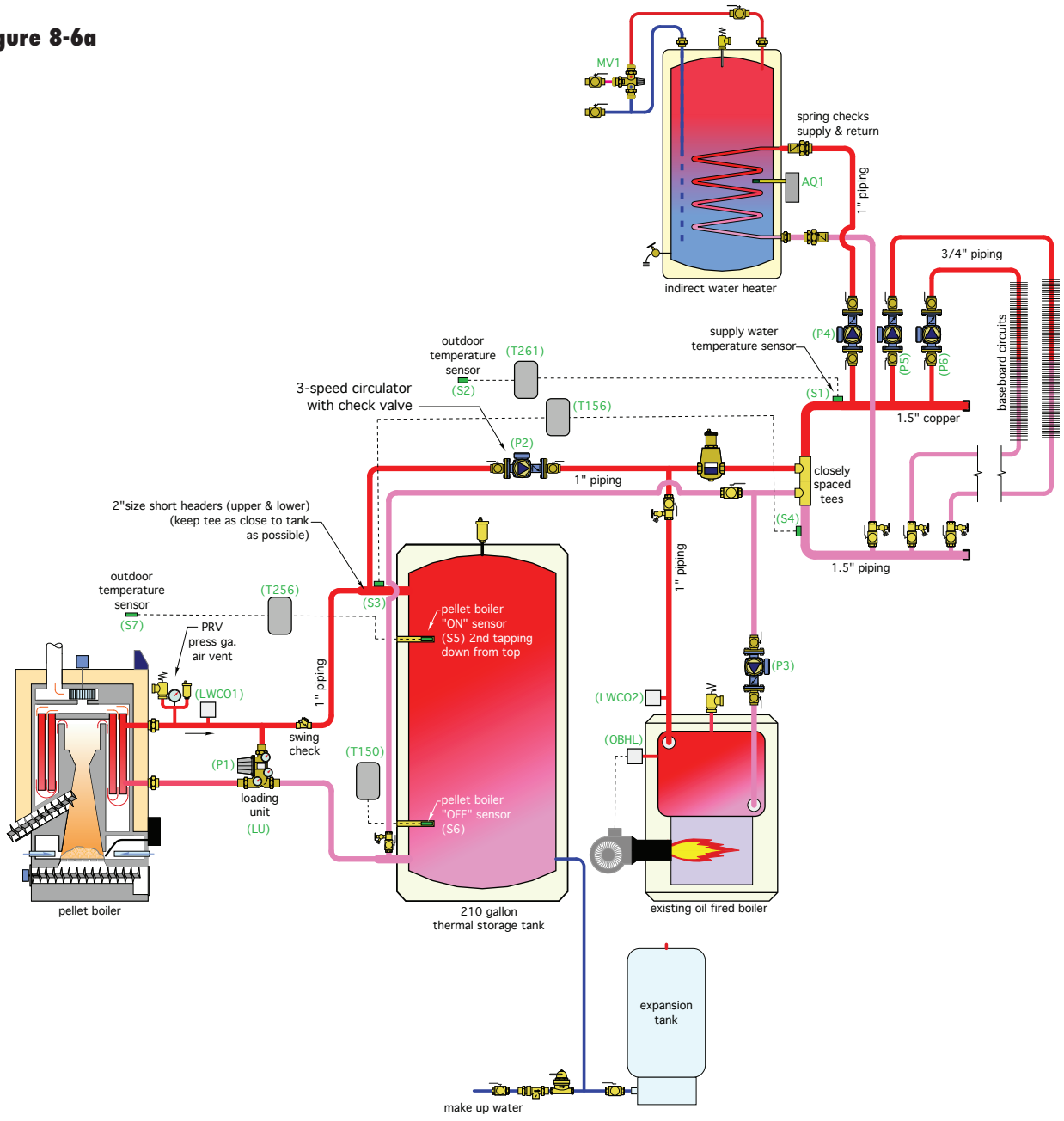
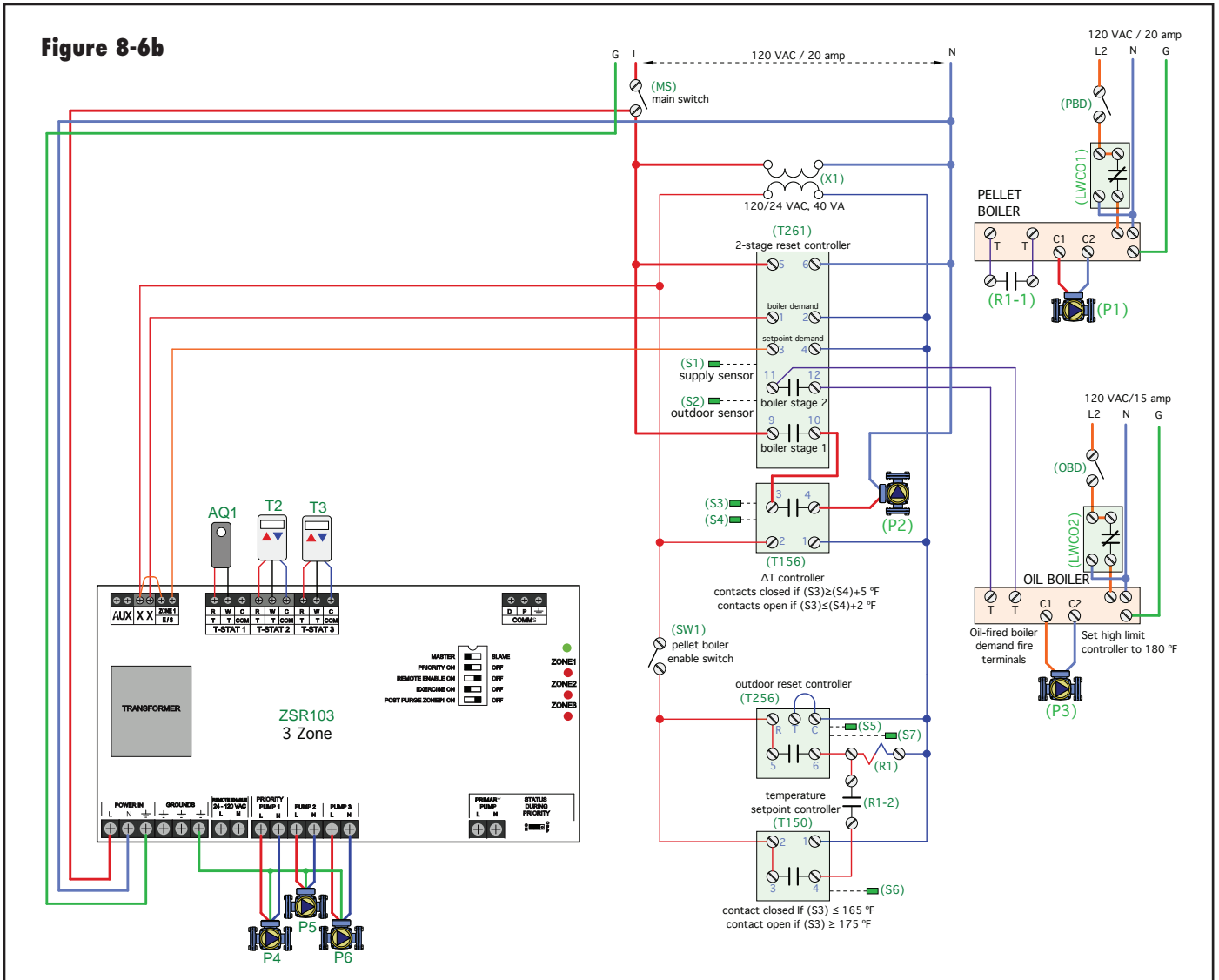

Figure 8-6b



EXAMPLE SYSTEM #6

The system shown in figure 8-6a is based on an existing heating system with 2 zones of fin-tube baseboard and an indirect domestic water heater. A pellet boiler with associated thermal storage is being added as the primary heat source, while the oil-boiler is retained for supplemental heating.

The pellet boiler responds to two temperature sensors in the thermal storage tank. The pellet boiler and its circulator are turned *on* when the temperature at the *upper* sensor drops below a specific temperature, which is calculated by the control system and based on the current outdoor temperature. The pellet boiler turns *off* when the temperature of the *lower* sensor reaches a fixed upper setpoint. This control action is designed to cycle the thermal storage tank through the widest possible

temperature range that is still compatible with the remainder of the system. This increases the average pellet boiler run time per start, which improves its efficiency and decreases emissions.

The oil-fired boiler is retained and used to provide supplemental heating input when necessary for either space heating or domestic water heating. The oil-fired boiler can also provide all space heating and domestic water heating if the pellet boiler is turned off or down for service.

Under certain conditions it is possible for heat to be simultaneously supplied from both the thermal storage tank and the oil-fired boiler. However, it is important that heat derived from the oil-fired boiler is not inadvertently moved back to the thermal storage tank. Controls are provided to determine when the thermal storage tank can



no longer make a net heat contribution to the distribution system, and will stop any further circulation through the thermal storage tank under those conditions.

The electrical wiring diagram for this system is shown in figure 8-6b.

DESCRIPTION OF OPERATION

SYSTEM POWER: The control system and circulators (P2, P4, P5, P6) are powered by a 120 VAC/20-amp circuit passing through the main switch (MS). The pellet boiler is powered by a dedicated 120 VAC/20-amp circuit passing through disconnect (PBD). Low water cutoff (LWCO1) must detect water present for 120 VAC to reach the pellet boiler. The oil-fired boiler is powered by a dedicated 120VAC/15-amp dedicated circuit passing through disconnect (OBD). Low water cutoff (LWCO2) must detect water present for 120 VAC to reach the oil boiler.

PELLET BOILER OPERATION: The main switch (MS) must be closed. The pellet boiler enable switch (SW1) must also be closed. The pellet boiler disconnect (PBD) must be closed, and the low water cutoff (LWCO1) must detect water present. 24 VAC is passed from transformer (X1) to outdoor reset controller (T256). The (T256) measures the current outdoor temperature at sensor (S7) and calculates the minimum target temperature in the upper portion of the thermal storage tank as measured by sensor (S5). When the temperature at (S5) drops 2°F below the calculated target temperature, the contacts in the (T256) close. This energizes the coil of relay (R1). Relay contact (R1-1) closes across the external demand terminals of the pellet boiler, enabling it to fire and turn on circulator (P1), which is contained within the loading unit (LU). Relay contact (R1-2) also closes, providing a second path for 24 VAC to reach relay coil (R1). 24 VAC also passes to the temperature setpoint controller (T150), which monitors the temperature of sensor (S6) in the lower portion of the thermal storage tank. If the temperature at (S6) is below 165°F, the contacts in (T150) will be closed, providing an alternate path for 24 VAC to reach relay coil (R1). The contacts in the (T256) will open when the temperature at sensor (S5) climbs to 2°F above the calculated minimum target temperature. However, because the contacts in (T150) are still closed, 24 VAC continues to power relay coil (R1) through contact (R1-2), and the pellet boiler remains on until the temperature at lower tank sensor (S6) reaches 175°F. The pellet boiler is protected against flue gas condensation by a thermostatic mixing valve within loading unit (LU).

Hot water from the pellet boiler is delivered to the upper tank header, where sensor (S3) is located. This hot water passes into the thermal storage tank if circulator (P2) is

off. A portion of the flow can also pass to the load through circulator (P2) if it is operating.

SPACE-HEATING DELIVERY: If the main switch is closed, 120 VAC is delivered to power up the (T261) controller and the (ZSR103) controller. 24 VAC is provided on the secondary winding of transformer (X1).

If either space-heating thermostat (T2) or (T3) call for heat, the multi-zone relay center (ZSR103) turns on the associated zone circulators (P5) or (P6). The (X X) contacts in the (ZSR103) close to pass 24 VAC to the boiler demand terminals (1 & 2) of the (T261) 2-stage reset controller. The (T261) measures the current outdoor temperature at sensor (S2), and calculates a target supply water temperature based on the outdoor temperature and its settings. It then measures the supply water temperature at sensor (S1). If the supply water temperature at sensor (S1) is slightly below the calculated target temperature, the stage 1 contacts in the (T261) close. This passes 120 VAC to the normally open contacts in the (T156) differential temperature controller. If the temperature measured at the upper tank header sensor (S3) is at least 5°F above the temperature at the return side of the distribution system measured at sensor (S4), the contacts in the (T156) close to pass 120 VAC to circulator (P2). However, if the temperature at (S3) drops to 2°F or less above the temperature at (S4), the contacts in the (T156) open, turning off circulator (P2). This prevents heat derived from the oil boiler from inadvertently entering the thermal storage tank.

If the temperature at sensor (S1) does not rise to approach the calculated target temperature within a short time, the stage 2 contacts in the (T261) close. This completes a circuit through the (T T) terminals on the oil-fired boiler's high limit controller. If the oil-fired boiler disconnect (OBD) is closed, and the low water cutoff (LWCO2) detects water present, and if the water temperature in the oil boiler is slightly below 180°F, the boiler's high limit controller will turn on circulator (P3) and fire the burner. Heated water from the oil boiler is delivered to the closely spaced tees in the distribution system. Note: Heat from the upper header of the thermal storage tank is still being delivered to the closely spaced tees by circulator (P2), unless the temperature at (S3) drops to within 2°F above the temperature at (S4).

DOMESTIC WATER HEATING MODE: When the temperature at aquastat (AQ1) on the indirect domestic water heater drops below its setpoint, the (ZSR103) controller turns on circulator (P4), and because domestic water heating is a priority load, it temporarily turns off circulators (P5) and (P6) if they are operating. 24 VAC from transformer (X1) passes through the (zone 1/EX) terminals

of the (ZSR103) and provides a setpoint demand to the (T261) controller at terminals (3 & 4). The (T261) targets a fixed (e.g., non-outdoor temperature dependent) supply water temperature at sensor (S1). If the temperature at sensor (S1) does not rise to approach this temperature within a short time, the stage 2 contacts in the (T261) controller close. This completes a circuit through the (T T) terminals on the oil boiler's high limit controller. If the oil-fired boiler disconnect (OBD) is closed, and the low water cutoff (LWCO2) detects water present, and if the water temperature in the oil boiler is slightly below 180°F, the boiler's high limit controller will turn on circulator (P3) and fire the burner. Heated water from the oil-fired boiler is delivered to the closely spaced tees in the distribution system, from where it will be routed through the coil of the indirect water heater by circulator (P4). Thermostatic mixing valve (MV1) is set to 115°F to protect against scalding.

SETTINGS:

T261 terminal unit # = 4 (fin-tube convector)
 T261 design water supply temperature (BOIL DSGN) = 170°F
 T261 boiler indoor temperature (BOIL INDR) = 60°F
 T261 outdoor design temperature (OUTDR DSGN) = 0°F
 T261 boiler minimum temperature (BOIL MIN) = 130°F
 T261 boiler max temperature (BOIL MAX) = 170°F
 T261 setpoint demand temperature = 160°F
 T261 boiler differential = 10°F
 T261 Fire delay of 30 seconds
 T261 advanced/installer DIP Switch = Advanced
 T261 rotate/off DIP switch = OFF
 T261 °C/°F = °F

T256 terminal unit # = 4 (fin-tube convector)
 T226 design water supply temperature = 170°F
 T256 occupied room temperature = 70°F
 T256 outdoor design temperature = 0°F
 T256 boiler minimum target temperature = 100°F
 T256 differential = 4°F
 T256 boiler max temperature = 180°F
 T256 warm weather shutdown = 65°F
 T256 °C/°F = °F

T156 ΔT setpoint = 5°F
 T156 ΔT differential = 3°F
 T156 storage max = 200°F
 T156 source minimum = 90°F
 T156 °C/°F = °F

T150 PWM DIP switch = OFF
 T150 setpoint = 170°F
 T150 differential = 10°F
 T150 heat/cool = heat
 T150 °C/°F = °F

ZSR103 master/slave = master
 ZSR103 priority = ON
 ZSR103 remote enable = OFF
 ZSR103 exercise = ON
 ZSR103 post purge on zone 1 = OFF

OBHL = 180°F
 OBHL differential = 8°F
 MV1 = 115°F

SUMMARY:

All hydronic heating and cooling systems should be properly documented. This helps ensure proper design and installation, and provides a higher probability that the system can be serviced over its full service life.

Quality documentation also conveys professionalism and competence to prospective clients.

This issue of *idronics* has addressed several forms of documentation, with emphasis on piping schematics, electrical schematics and description of operation. Other possible documentation includes a tubing layout plan for radiant panel systems, circulator and valve schedules, and a heat emitter or chiller water terminal unit placement drawing.

A wide variety of computer-based drawing software products are available, many at relatively low cost to aid in creating documentation drawings. Word processors and spreadsheets are widely available for creating descriptions of operation and schedules.

Caleffi offer several tools that can assist designers and installers with proper documentation. These include the Caleffi schematic library, Z-one wiring guide, and BIM object files.

APPENDIX A1: Caleffi component symbol legend

CALEFFI COMPONENTS

Float - type air vent

inline check valve

3-way thermostatic mixing valve

manifold station with balancing valves

DISCAL air separators

QuickSetter-balancing valve

DIRTAL dirt separators

pressure-reducing valve (3/4")

geothermal manifold station

distribution station

DIRTMAG dirt separators

Autofill backflow preventer comb

boiler tm kit

HYDROFILL

backflow preventer

pressure-reducing valve

HYDROFILL

DISCALDIRTMAG air & dirt separator

DISCALDIRT air & dirt separator

multi-zone controls

differential pressure bypass valve

zone valve (2 way)

Hydro Separator

Hydro Separator

Hydro Separator

single zone control

zone valve (3 way)

thermoelectric zone valve (2 way)

ThermoCon buffer tank

variable orifice balancing valve

motorized ball valve (2 way)

SEP4

SEP4

SEP4

HydroBlock mixing units

FLOWCAL balancing valve

FLOWCAL balancing valve

fixed orifice balancing valve

thermostatic radiator valve

thermostatic radiator valve

dual isolation valve for panel radiators

QuickSetter balancing valve w/ flowmeter

boiler protection valve

ThermoBlock

high-temperature solar DISCAL air separators

high-temperature solar pressure relief valve

high-temperature solar air vent

high-temperature shut-off valve for solar air vent

high-temperature solar 3-way thermostatic mixing valve

isolar differential temperature controller

high-temperature solar expansion tank

Hydroink (4 configurations)

symbols are in Visio library @ www.caleffi.com

APPENDIX A2: Generic component symbol legend

GENERIC COMPONENTS

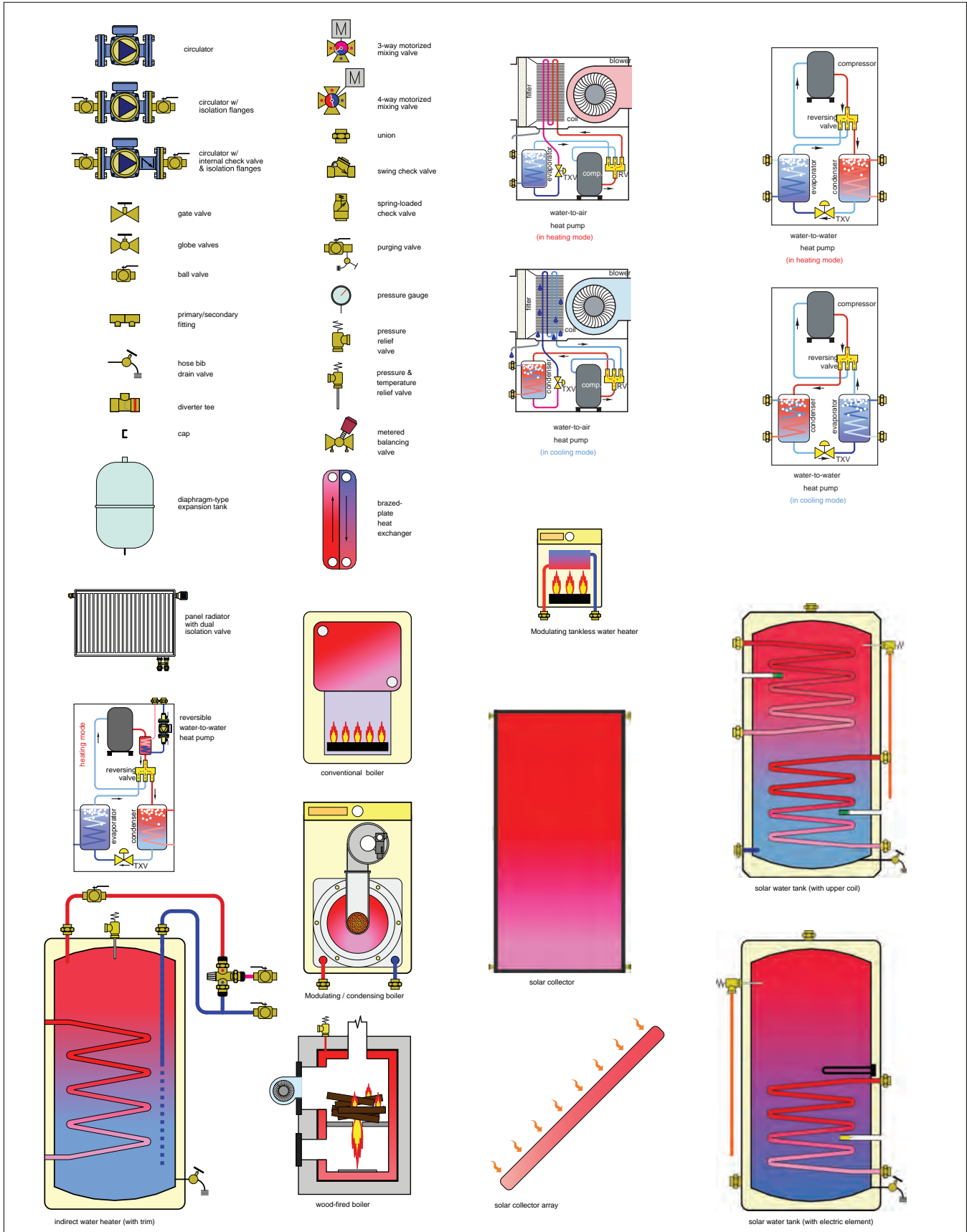

APPENDIX B: Suggested symbol legend for common electrical components

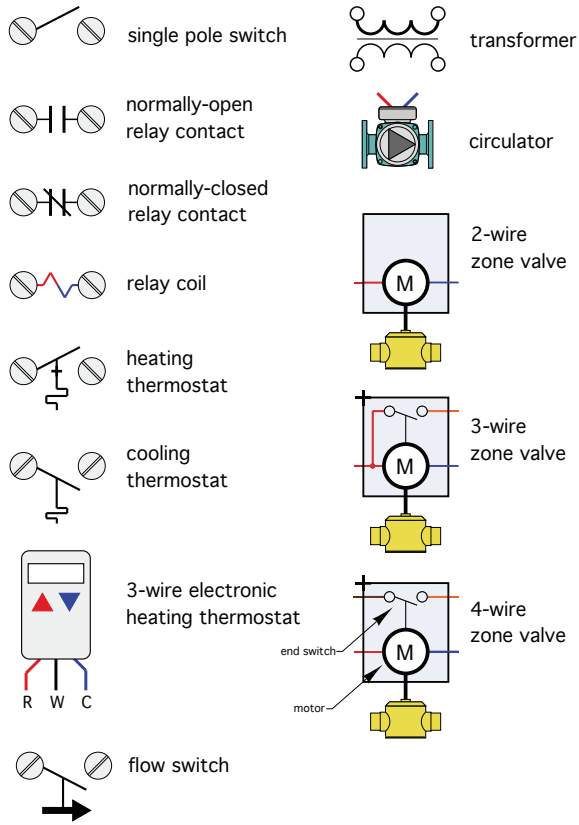

Poles & Throws for switches and relays

contact designation	switch contacts	relay contacts
Single Pole Single Throw SPST	pole 1 — —	pole 1 — —
Double Pole Single Throw DPST	pole 1 — — pole 2 — —	pole 1 — — pole 1 — —
Triple Pole Single Throw 3PST	pole 1 — — pole 2 — — pole 3 — —	pole 1 — — pole 2 — — pole 3 — —
Single Pole Double Throw SPDT	pole 1 — —	pole 1 — —
Double Pole Double Throw DPDT	pole 1 — — pole 2 — —	pole 1 — — pole 2 — —
Triple Pole Double Throw 3PDT	pole 1 — — pole 2 — — pole 3 — —	pole 1 — — pole 2 — — pole 3 — —

APPENDIX C: Symbols legend for ZSR & ZVR electrical relay boxes

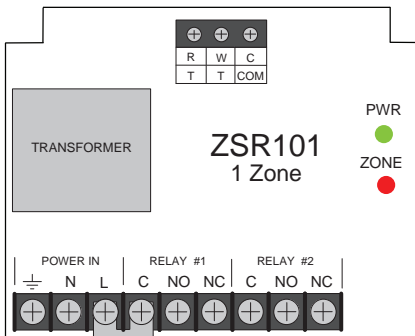
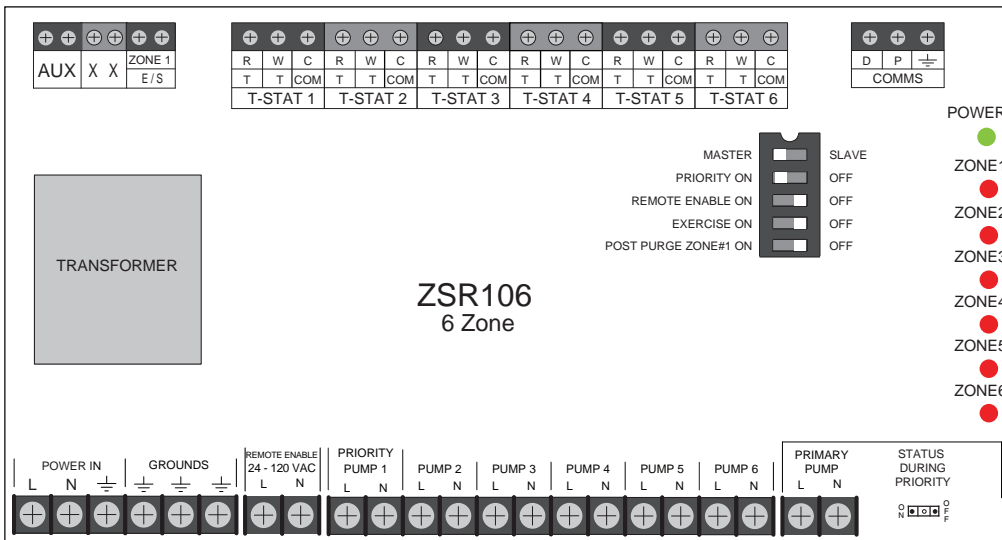
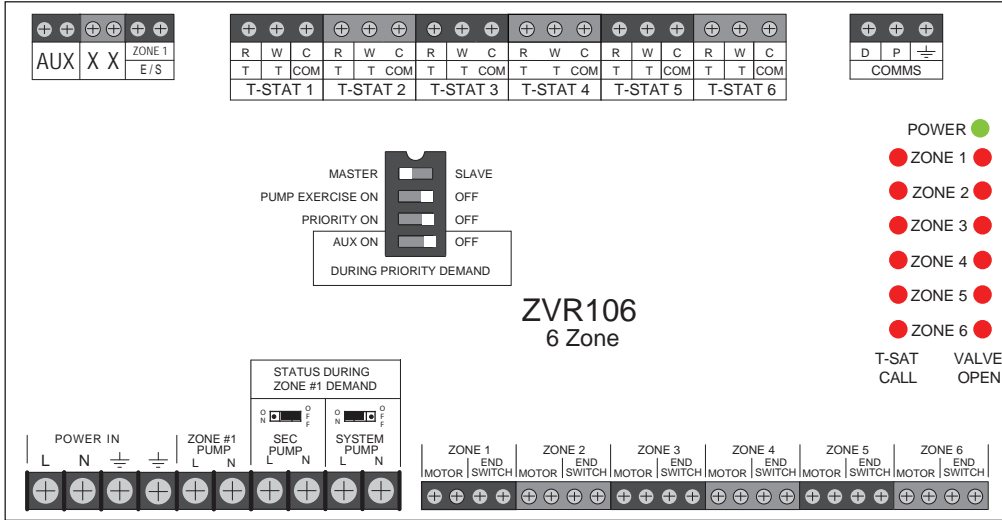



10 Years of Educational Excellence



www.caleffi.com
Milwaukee, WI USA

