

DATA EASY datalogger

© Copyright 2025 Caleffi

Code 750351 001

INSTRUCTION AND INSTALLATION MANUAL



Function

The DATA EASY datalogger is a device designed to acquire and record the data originating from devices using M-Bus communication protocol on RS485.

It can manage up to 50 devices, including:

- Conteca and Conteca Easy heat meters
- Aquapro Easy consumption loggers

It is also compatible with heat meters that use the standard M-Bus protocol, such as the Sensonical and Sensonical Ultra models.

Thanks to the integration of a 4G router (with SIM owned by Caleffi S.p.A.), it is possible to schedule the automatic sending of consumption readings by email, simplifying remote management and monitoring.

Product range

750351 001 DATA EASY datalogger

Technical specifications

Electric specifications

Electric supply: 24 V = (DC) +/- 10 %, 24 V ~ (AC)
(min 20 V ~ (AC), max 40 V ~ (AC))

Installation category: Class II

Maximum power consumption: 14.5 W 15 VA

Ethernet: ETH1

Fieldbus: M-BUS on RS485
M-Bus

Mechanical specifications

Working temperature range: 0–50 °C

Storage temperature range: -25–65 °C

Mounting: on 35 mm DIN rail (EN60715)

Protection class: IP20 (EN60529)

M-BUS (M1M2) and RS485 (B1B2) interface

Baud rate: 2400-9600 bps

Maximum number of connectable CONTECA meters (B1B2): 50

Maximum number of connectable SENSONICAL meters (M1M2): 20
(80 with the use of 1 level converter code 750551)

Reading interval: settable

Device search: by primary (IDB) and secondary (SN) address

Devices supported: Conteca Easy 7504/7507/7502 meters
Aquapro Easy 750947 600 loggers
Conteca 7554/7557 meters
(with year of production from 2015)

M-Bus supported devices: Sensonical/ Sensonical Ultra meters

Datalogging

Daily data sending frequency: Daily

User interface: Web server

4G Router device features

Electric supply: 100/240 V ~ (AC)

Maximum power consumption: < 7 W

Ethernet: 2 ports

Antennas: outdoor

Working temperature range: 0–50 °C

Working humidity range: 10–90 % (non-condensing)

Connections: UMTS, HSDPA, EDGE, GPRS, GSM, LTE, wifi

SIM type: M2M

Dimensions

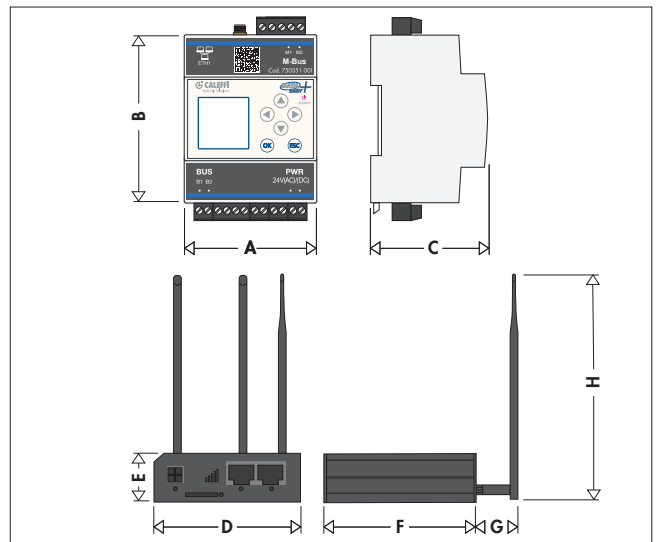

Code	A	B	C	D	E	F	G	H	kg
750351 001	72	90	6	74	25	83	35	165	1,1

Component description

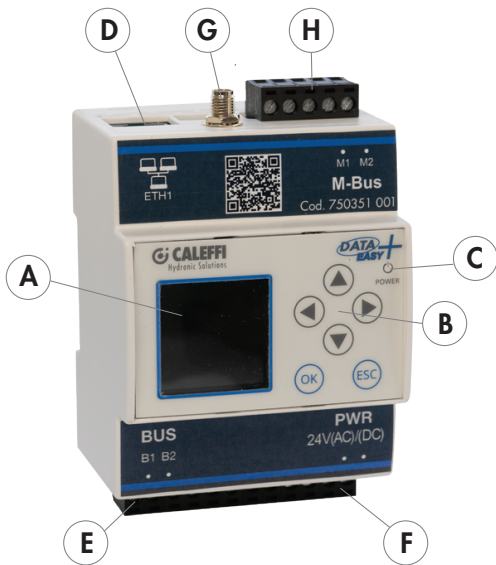

- A - Display
- B - Navigation keypad
- C - Operating status LED
- D - Ethernet port
- E - M-BUS connector on RS485 (**B1 - B2**)
- F - Power supply input connector 24 V ~ (AC) / 24 V = (DC) (**PWR**)
- G - Antenna connector **NOT USED**
- H - M-Bus connector (**M1 - M2**)

The navigation keyboard has 6 buttons that allow you to navigate through the menus.

The functions of the buttons are based on the menu displayed:

	<ul style="list-style-type: none"> • Confirm a set field or value • Go to the main menu or submenu
	<ul style="list-style-type: none"> • Deselect field or clear a value • Return from a submenu to the main menu
	<ul style="list-style-type: none"> • Go to the previous menu or submenu • Move the cursor to the left
	<ul style="list-style-type: none"> • Go to the next menu or submenu • Move the cursor to the right
	<ul style="list-style-type: none"> • Scroll to the top of a page • Select / switch from letters A ... Z and digits 0 ... 9
	<ul style="list-style-type: none"> • Scroll down one page • Select / switch from letters A ... Z and digits 0 ... 9

Installation

Notes for the installer:



Assembly and electrical DATALOGGER connections.

PRELIMINARY WARNINGS



- Make sure the electrical cabinet in which the device is installed is not connected to the power supply.
- Check for the presence of general protection devices for the electric supplies (fuses, circuit breakers, RCDs).
- Make sure the electric supply voltage is in compliance with the device operating limits and that the power supply unit power rating is sufficient to ensure operation of all devices connected to it, checking the maximum power consumption of each device (24 V = (DC) +/- 10 %, 24 V ~ (AC) (min 20 V ~ (AC), max 40 V ~ (AC)).

It is designed for mounting on a 35 mm DIN rail. It occupies the equivalent of four standard modules on DIN rail.

DATALOGGER and ROUTER assembly procedure on DIN rail

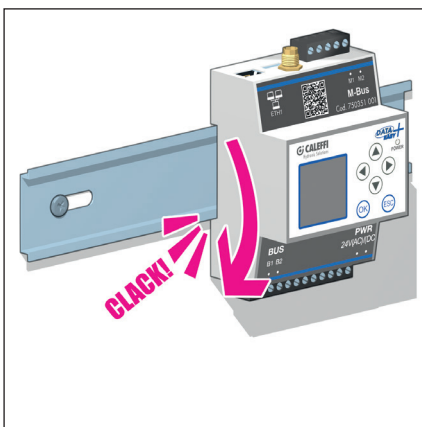

DATALOGGER electrical connections

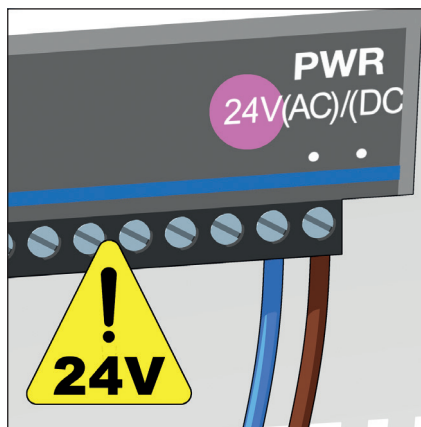

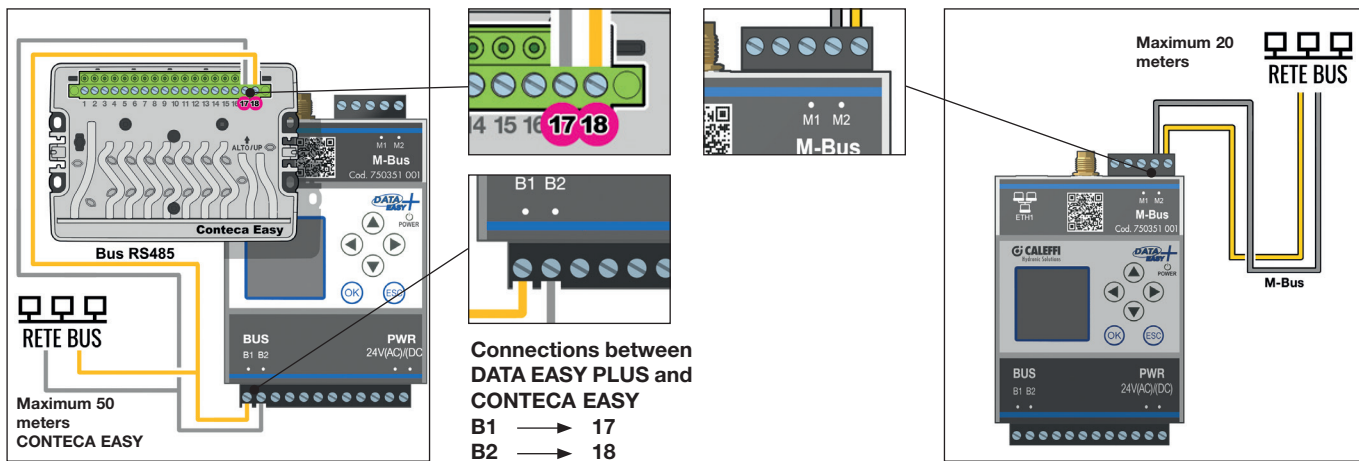

Connecting devices

The connection between the DATA EASY device and the various heat meters is via bus cable. The maximum total length of the bus cable is 1200 m and it must be inserted in a dedicated raceway.

The BUS cable is a 2-way cable (type LIYCY - cross section 2 x 0.75 mm²). LSC bus cable code 755855 (supplied in 100 m coil).

Star and shaft connections are allowed. The in-out connection IS not recommended and ring closure is to be avoided.

The BUS cable and the same DATA EASY device must be positioned away from power cables, inverters, pumps and in any case away from sources that emit radio frequency.

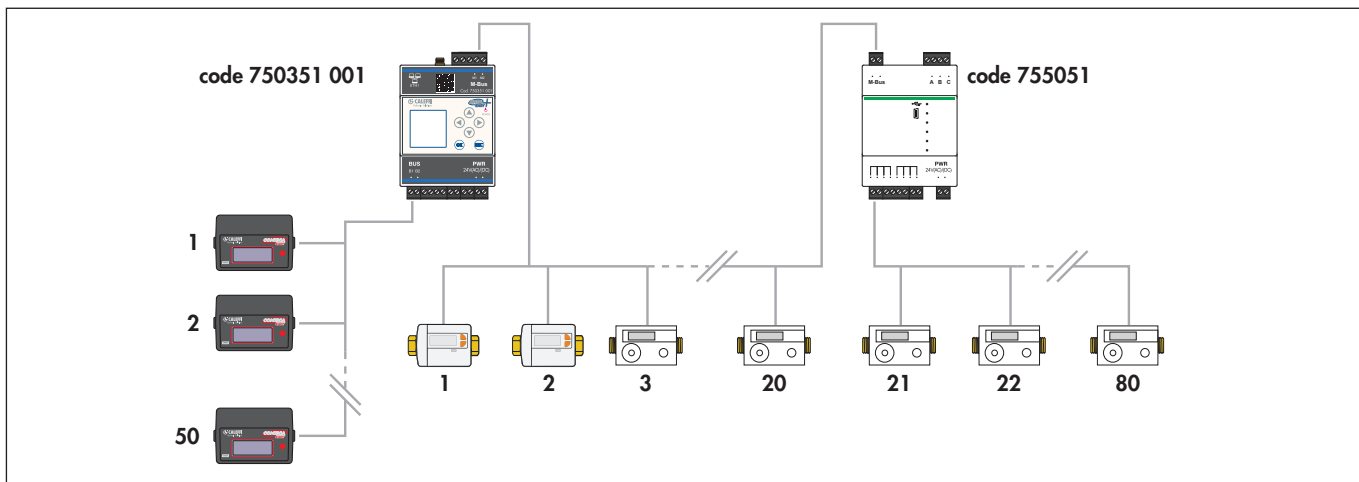

Up to 20 devices can be connected to the M1-M2 line of DATA EASY. By using level converter (code 755051) it is possible to extend the line to a maximum of 80 metres. The extension can support up to 60 devices.

ROUTER assembly and electrical connections

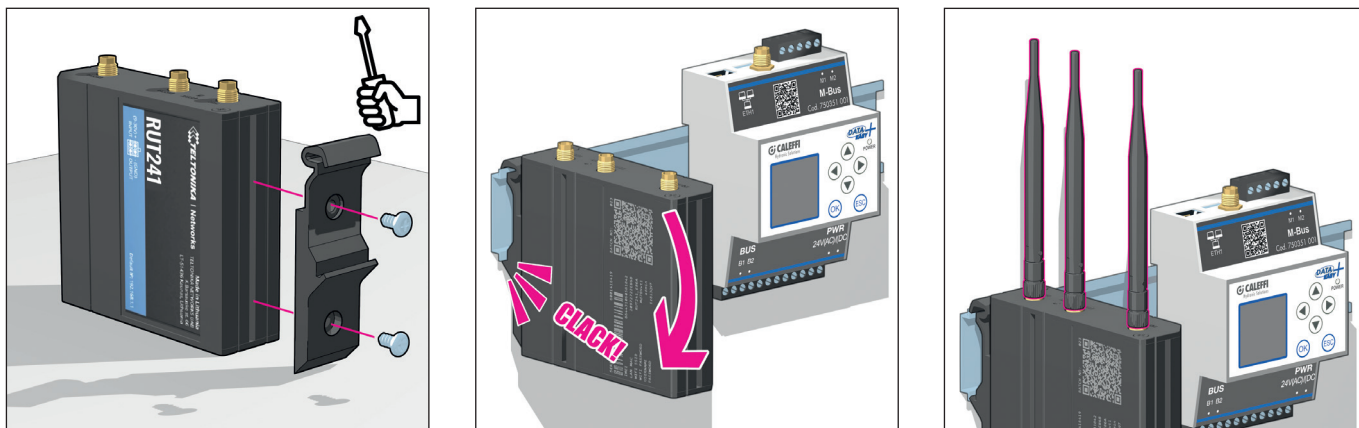

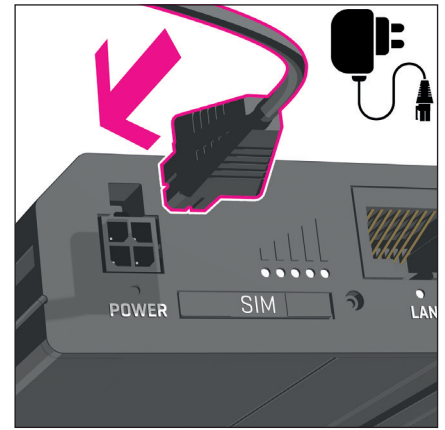
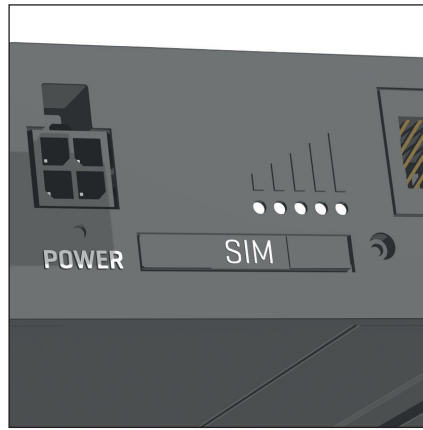
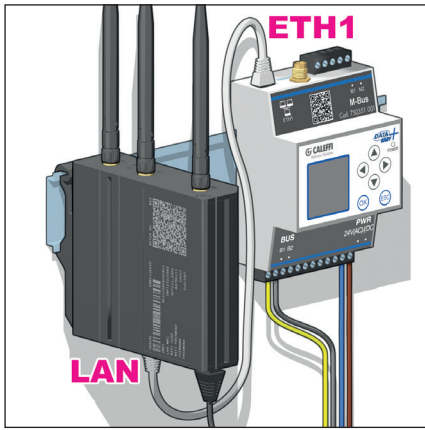

Pay particular attention to the presence of the GSM radio signal on whose network data transmission will be operational through the 4G router connected to the Datalogger: without the presence of the GSM signal the DATA EASY Datalogger will not work properly

SAFETY INSTRUCTIONS

IMPORTANT!

Read this booklet carefully before installing and/or using the equipment and store it in an accessible place. This equipment is a component that is part of complex installations.



IMPORTANT!

Installation and maintenance must only be carried out by qualified personnel authorised to install live electrical equipment. Electrical systems and equipment installation rooms must comply with the safety, accident prevention and fire prevention regulations in force in the country of use.

1. This appliance is unsuitable for use in explosive or potentially explosive atmospheres.
2. At the time of installation or when work is required on the equipment, it is necessary to scrupulously follow the rules shown in this manual and apply all the appropriate precautions.
3. This equipment is not suitable for use by children or the infirm without proper supervision.

GENERAL WARNINGS

1. If, after unpacking the equipment, you notice any anomaly, do not use the equipment and contact a Service Centre authorised by the Manufacturer.
2. Only request original spare parts: failure to comply with this rule will void the warranty.
3. The Manufacturer declines any responsibility and does not consider the warranty valid in the following cases:
 - The warnings and safety regulations indicated above, including those in force in the countries of installation, are not complied with.
 - Failure to comply with the instructions given in this manual.
 - Damage to people, animals or property, resulting from incorrect installation and/or improper use of products and equipment.
4. The Manufacturer also reserves the right to cease production at any time and to make any changes it deems useful or necessary without prior notice.

LEAVE THIS MANUAL AS A REFERENCE GUIDE FOR THE USER. DISPOSE OF THE PRODUCT IN COMPLIANCE WITH CURRENT LEGISLATION. THE MANUFACTURER RESERVES THE RIGHT TO CEASE PRODUCTION AT ANY TIME AND TO MAKE ANY CHANGES DEEMED USEFUL OR NECESSARY WITHOUT THE OBLIGATION OF PRIOR NOTICE.

DATA EASY: OPERATIONS ON THE DEVICE

First access:

If not previously set, at the first activation of DATA EASY it is necessary to set the language of the data logger and the access code.

Select language:

The following languages are currently available:

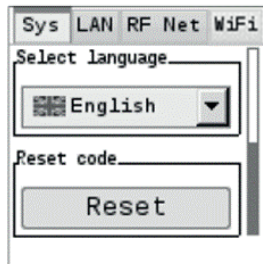

- German
- English
- Italian
- French
- Dutch



The selected language will be applied to both the display and the user interface of the DATA EASY web server.

The set language is also used for emails, reports and alarm notifications. It is therefore very important that the language is set correctly during commissioning.

After the first access it is possible to change the set operating language directly on the display. After entering the password, select the language in the menu.

Settings -> Sys -> Select language by pressing the  and  keys.

Access code:

Define an 8-digit access code. Use the  and navigation  buttons to choose a number from 0...9. Press OK to move to the next digit. You must re-enter this code again to confirm.

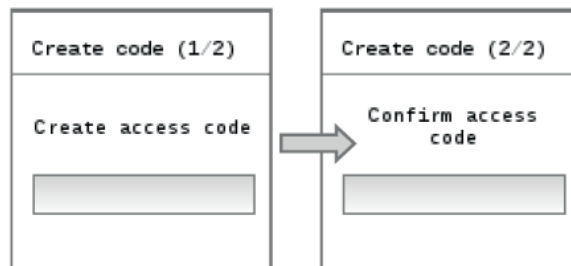

After the first login you can change the code directly on the display.

Select **Settings -> Sys -> Access code -> Edit** and press the **OK** button to reset the access code. The current access code must be entered before you can enter and confirm the new code.

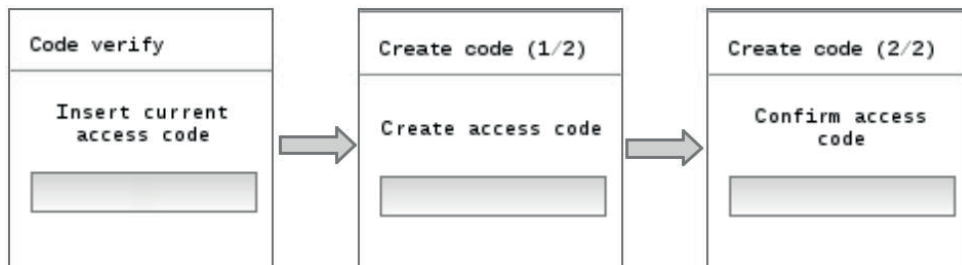

To access the main menu, enter the access code correctly (def. 0000000). The display automatically turns off after 10 minutes, to turn it on press a navigation button



Select the individual numbers using the arrow keys and confirm with the OK button. The cursor moves to the next position on the 8-digit access code.

After entering the access code correctly, the main menu is displayed. It consists of five pages:

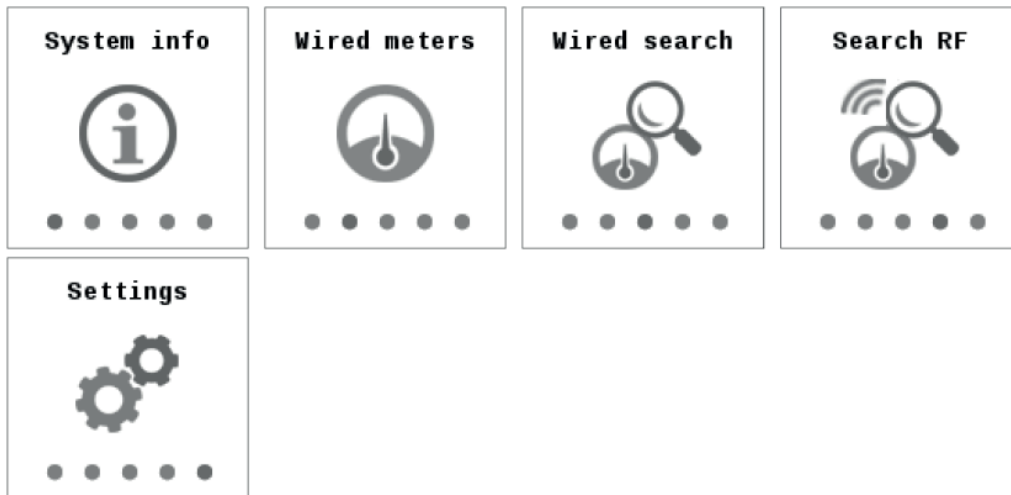

System info:
Includes information about the DATA EASY and the connection status

Wired meters:
Displays the list of connected M-Bus devices and allows you to view the data.

Wired search:
Displays the list of connected M-Bus devices and allows you to view the data.

Search RF:
Do not use

Settings:
Includes some DATA EASY settings.

"System Info" menu

Select the "System Info" menu and press the **OK button** to access the submenu.

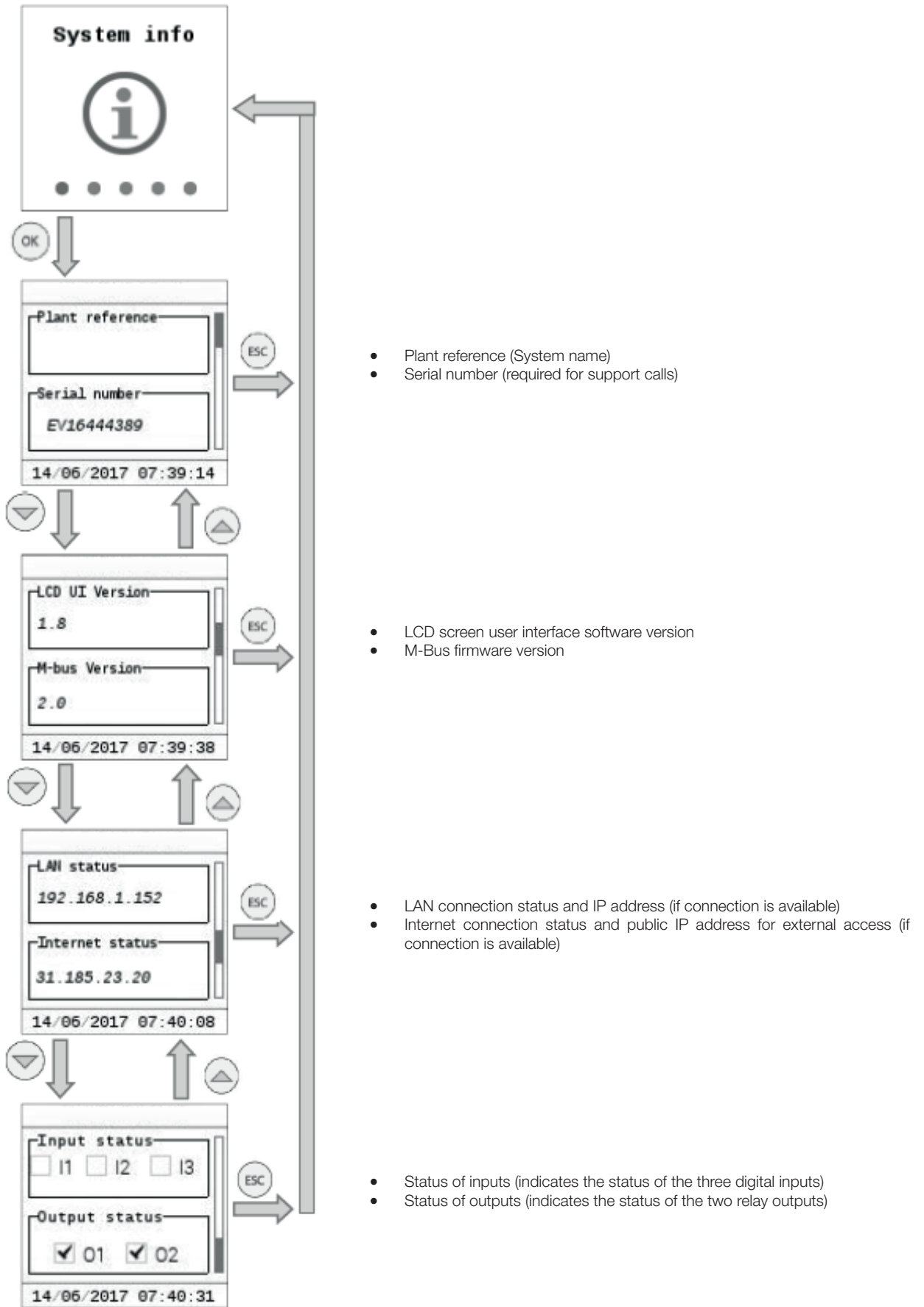

"Wired meters" menu

Select the menu **"Wired meters"** and press **OK** to access the submenu.

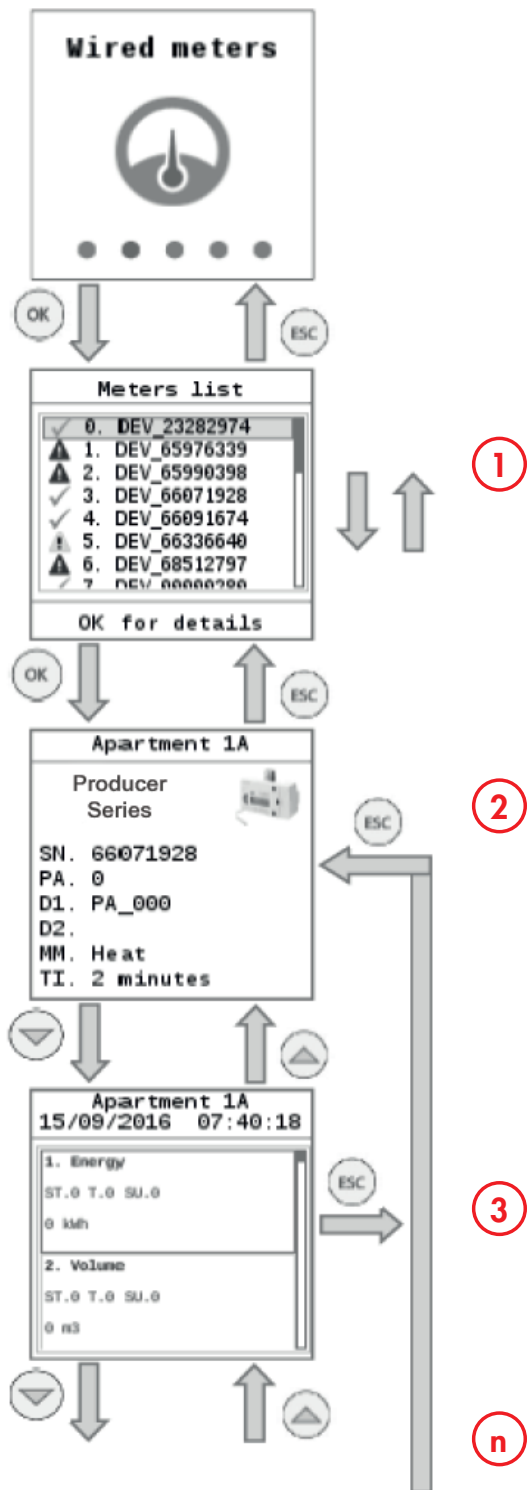

1

List of saved meters. Each meter is identified by the first 8 digits of the serial number (e.g. 10485504).

The following symbols are displayed in the first column:

- ✓ OK: the last reading was completed successfully.
- ⚠ Device error: an error has been reported via M-Bus.
- ⚠ Communication error: no communication with the device.

You can navigate the list with the navigation buttons and .

Press OK to consult the data for the selected meter.

2

The first panel provides general information about the meter, namely:

SN: Serial Number: manufacturing number
 PA: Primary Address: primary address (IDB)
 D1: Description, designation
 LN: M-Bus line
 MM: Measured medium
 TI: Time interval: reading frequency

3

Displays the values since the last meter reading, if available.

The navigation buttons  and  lead to other meter fields for this reading time.

n

The following image explains in detail the meter configuration fields shown on the display.

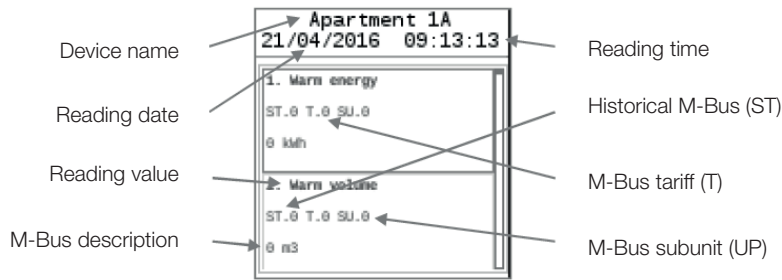

Device name: The setting can be configured via web operations in the menu **Settings -> Wired meters -> Meter setup -> Select meter -> Data Points settings**

Reading date: Displays the date of the meter reading

Reading time: Displays the time of the meter reading

Reading value: Displays the value with units when the meter is read

M-Bus description: Shows a description of the field according to the M-Bus protocol

M-Bus tariff: Displays the tariff number of the displayed M-Bus data point. Refer to the meter documentation for more information

M-Bus subunit: Displays the secondary unit number for the M-Bus data point. Refer to the meter documentation for more information

Historical M-Bus: Displays the historical number of the displayed M-Bus data point. Refer to the meter documentation for more information

IMPORTANT! The display only shows meter fields where the View Data option is selected. The setting can be configured through web operations in the menu:

Settings -> Wired meters -> Meter setup -> Select meter -> Data Points configuration

"Wired search" menu

In the "Wired search" menu, press **OK** to start a scan of the connected meters.

The search criteria to be set are:

- M-Bus line: B1B2; M1M2
- Scanning speed: 9600 / 2400 bps
- Scan type: Serial number or ID

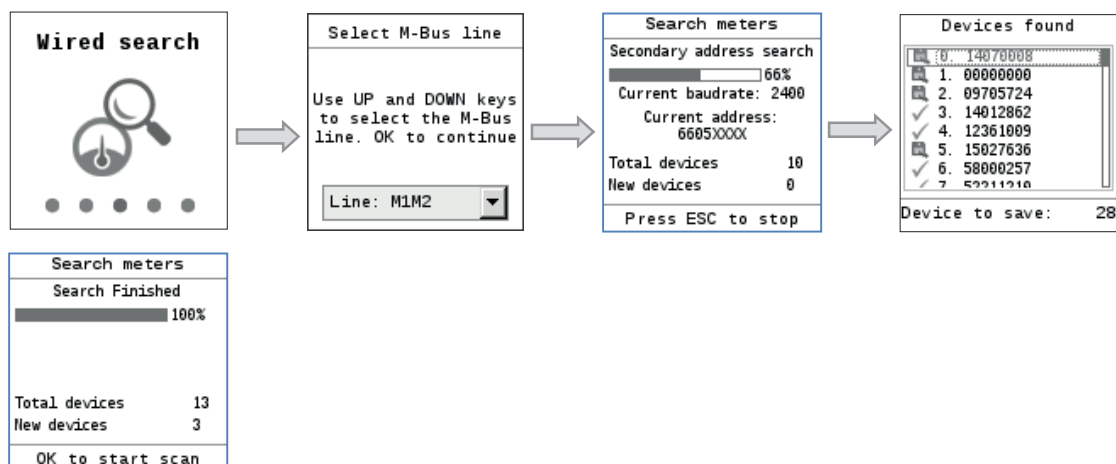

Check the meters and save:

A list of devices found is displayed at the end of the meter scan.
Press **OK** to save all the newly found meters and add them to the list of devices.
The **ESC** button does not add the newly found meters to the list of devices.
To change the meter settings via Web operation, see the menu:
Settings -> Wired meters -> Device settings.

Settings menu

Select the “Settings” menu and press OK to access the 4 submenus.

- System
- LAN
- RF network
- Wi-Fi

- You can navigate the submenus with the navigation buttons ◀ and ▶ .
- You can navigate within the submenus with the navigation buttons ▲ and ▼ .
- The OK button selects a field for editing and then confirms the value entered.

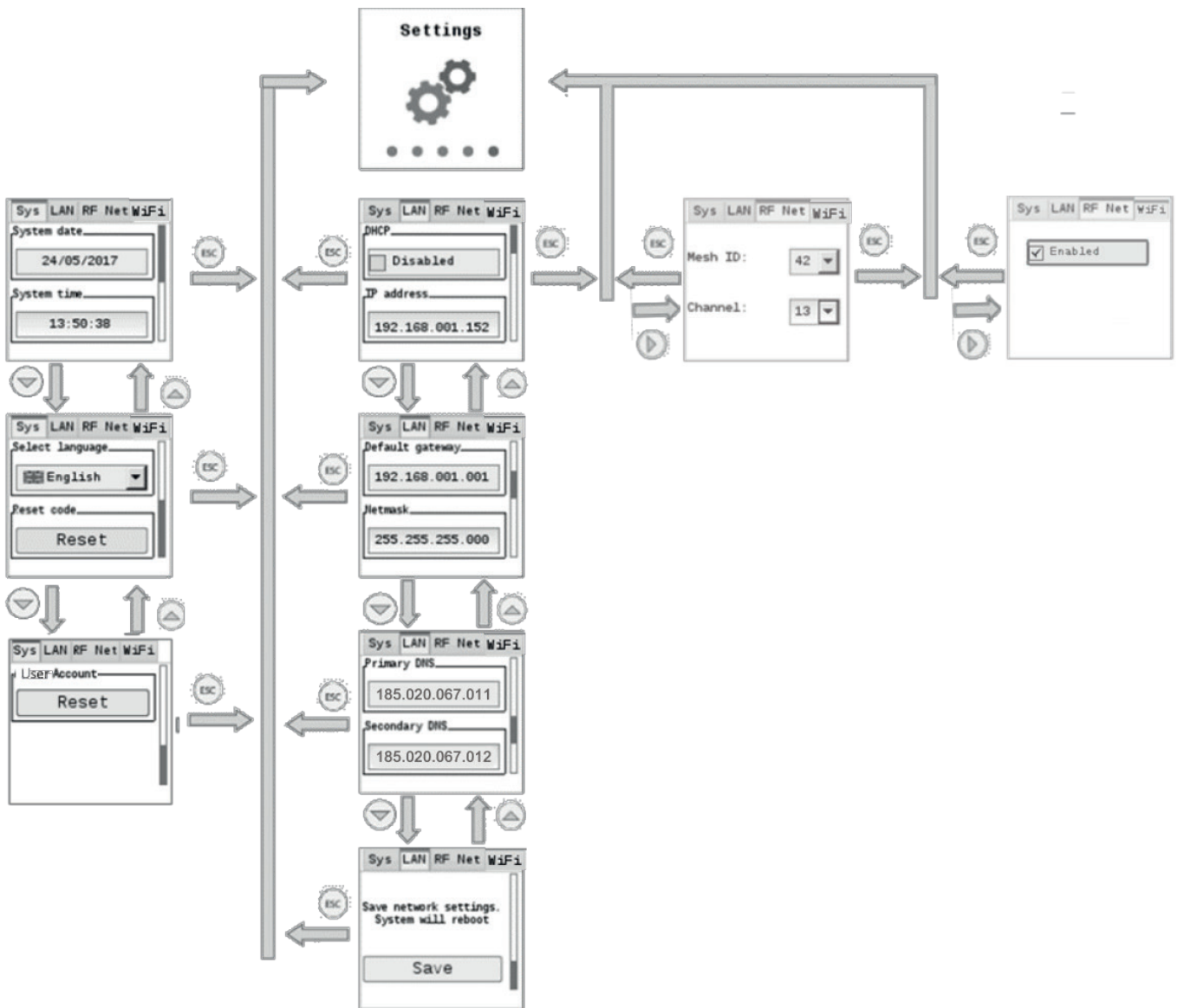

Sys

The **SYS submenu** has the following settings

- System date:** Enter the current date of the DATA EASY
- System time:** Enter the current time of the DATA EASY
- Select language:** Select the DATA EASY display language
- Reset code:** To change the current access code of the local display. You will be prompted to enter a new access code
- User Account:** Resets all users previously created via Web Server. New users may be created. Leave all other settings unchanged.

LAN

The **LAN submenu** has the following settings:

- DHCP:** Enables or disables the DHCP client on DATA EASY. DATA EASY automatically draws its IP address from the DHCP server (router) if the DHCP client is enabled. The following parameters must be entered manually if the DHCP client is disabled
- IP address:** IP address of the DATA EASY. It is not settable with DHCP enabled.
Default value: 192.168.1.110
- Default gateway:** The standard gateway represents the interface between the local and public network. In general, the IP address of the router is entered here.
With DHCP enabled you do not need to set it up.
Default value: 192.168.1.1
- Netmask:** The IP subnet mask sets the size of the network. With DHCP enabled you do not need to set it up.
Default value: 255.255.255.0
- Primary DNS:** The DNS (Domain Name System) name server on the Internet links a globally valid name to a domain with an IP address (e.g. Domain www.xxxxxx.com with IP address 146.254.191.150). The setting corresponds to the IP address for the next router or DNS name server that recognises a queried name (domain) or another DNS name server. The setting is typically identical to the setting for the standard gateway. No need to enable DHCP. If DHCP settings are disabled, contact your local administrator for parameter specification.
Default value DNS1: 8.8.8.8.
- Secondary DNS:** A secondary DNS name server is defined only for redundant systems. The settings are generally empty. With DHCP enabled you do not need to set it up.
Default value DNS2: 8.8.4.4
- Save:** Current network settings are saved and DATA EASY restarts

RF Net:

Do not use

Wi-Fi:

In the Wi-Fi submenu you can activate or deactivate the Wi-Fi connection.

PC > DATA EASY DIRECT CONNECTION

THE DATA EASY web server can be accessed by connecting the PC to the ETH port of the DATA EASY device via an Ethernet cable.

Set up your PC network card to allow communication between the two devices. To change the PC network card IP address, refer to the user manual of the Operating System installed on your PC.

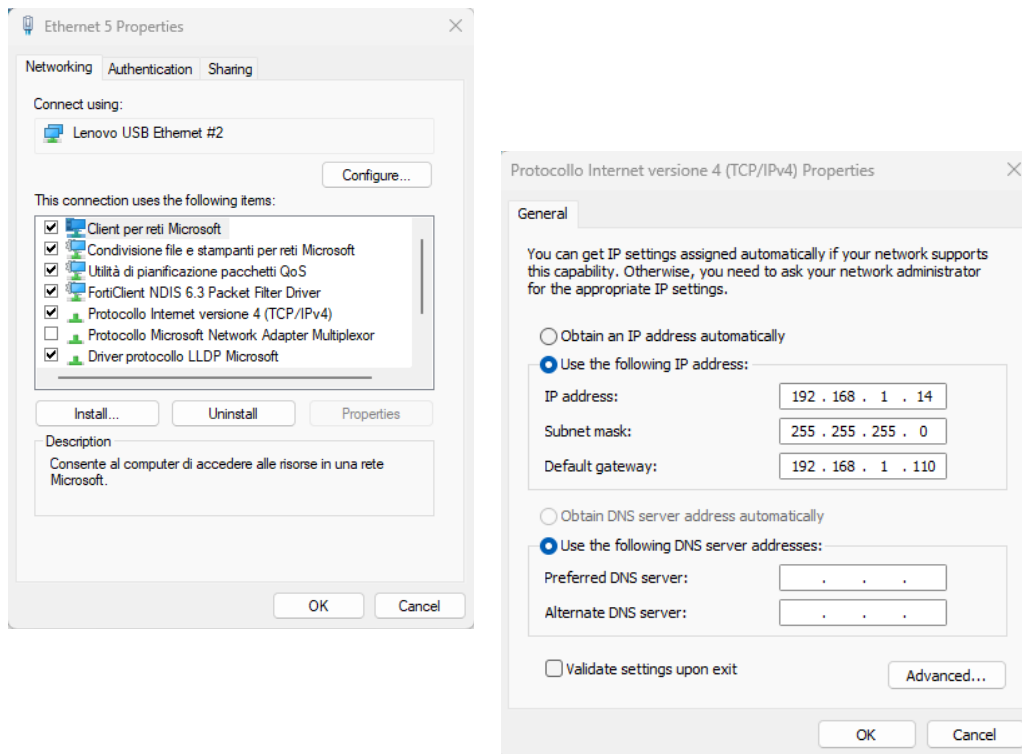

Enter the DATA EASY IP address (e.g. <https://192.168.1.110>) in the browser (Chrome, Safari, Firefox, Edge). If a screen similar to the one below appears, select "Advanced"

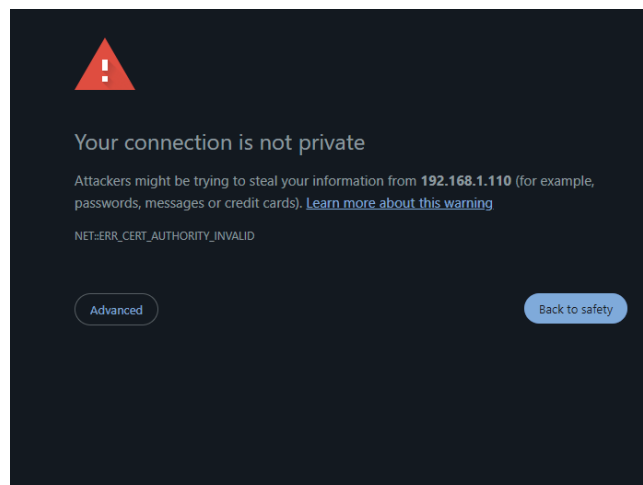

and then "Proceed to xxx.xxx.xxx.xxx"

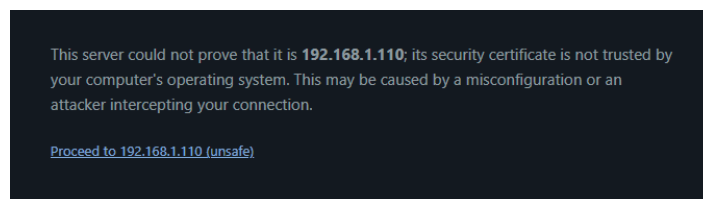

PC > DATA EASY WI-FI CONNECTION

DATA EASY has a Wi-Fi connection. When Wi-Fi is enabled, DATA EASY creates an access point with a specific SSID (Wi-Fi name). This SSID is composed of the datalogger model (DATA EASY) and its serial number (EVxxxxxxx). You can activate Wi-Fi by holding the ESC key for more than 5 seconds. Then, the SSID is for example DATA EASY -EV12345678. Once Wi-Fi is enabled, it remains activated for 4 hours.

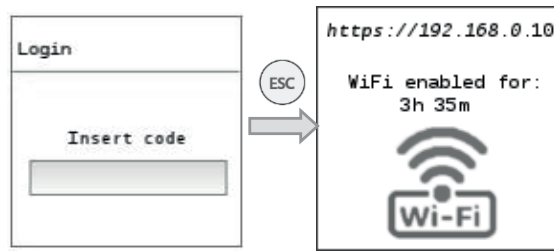

To access the web server, connect to the network and enter the DATA EASY IP address (e.g. <https://192.168.0.10>) in the browser (Chrome, Safari, Firefox, Edge).

If a screen similar to the one below appears, select "Advanced"

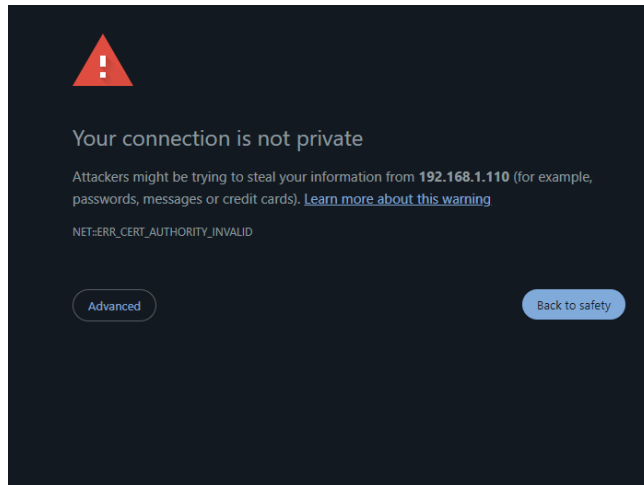

and then "Proceed to xxx.xxx.xxx.xxx"

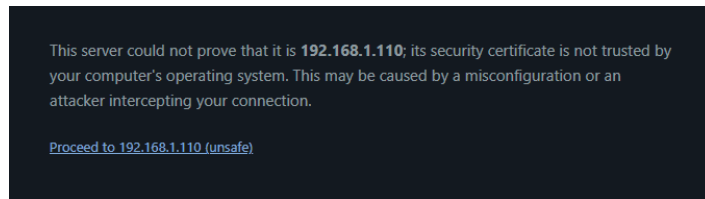

LOGIN

The datalogger moves to the login page after correct registration.

Now you can log in using the new:

- username: admin
- password: Admin_01!

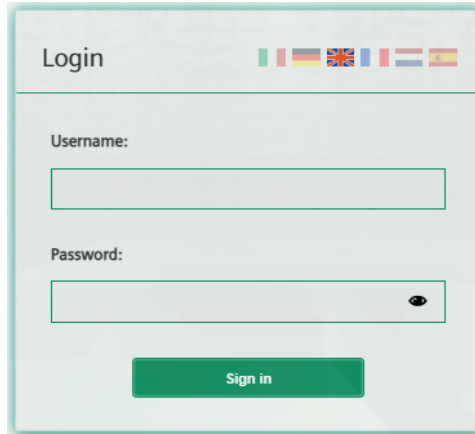

Any DATA EASY for which the Web Access service (also referred to as the "reachability service") is activated, can also be reached at:

[<serial_number>https://ev.net.sghiot.com](https://ev.net.sghiot.com)

Where <serial_number> is the serial number of the device (consisting of eight digits).

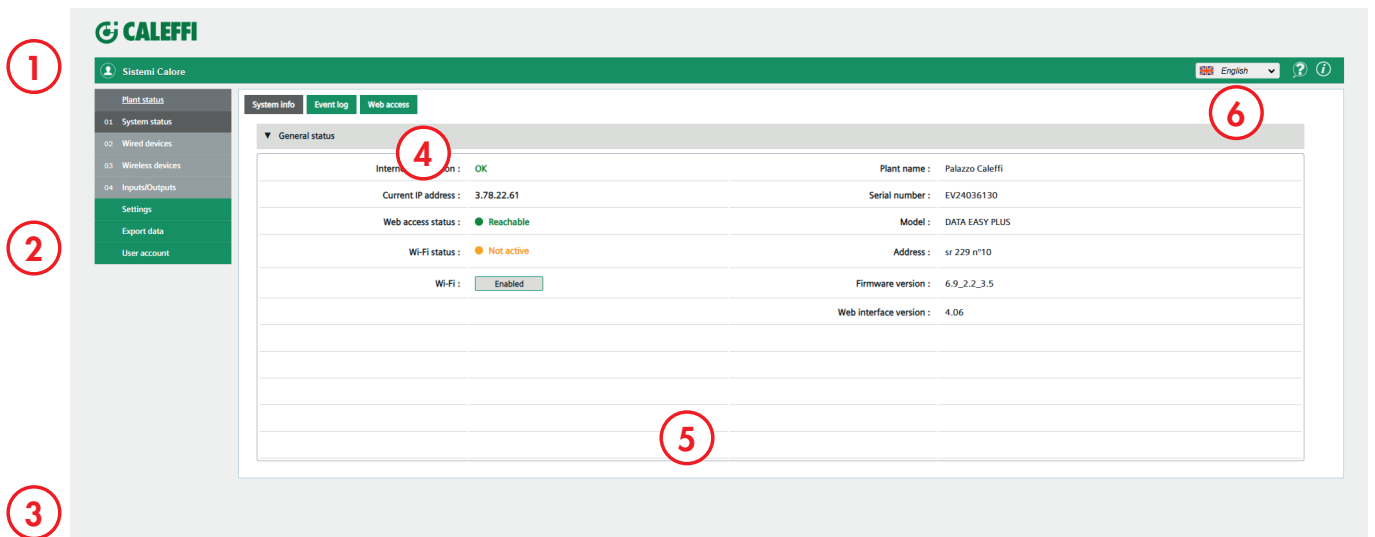

- 1 The following information is displayed on the title line:
 - Name of the logged in user.
 - Language section. Information on "Open source software" packages and licenses.
- 2 Main navigation using the main menus:
 - System status
 - Settings
 - Export data
 - User account
- 3 Status Information:
 - M-Bus status
 - M-Bus wireless status
 - Number of users connected
 - Date and time
- 4 Secondary navigation via submenu.

5

About the menu and submenu page

6

Select the language of the datalogger

The operating language for the software interface can be set in the title line on the right. The following languages are available:

- English
- German
- Italian
- French
- Dutch

IMPORTANT! The default language used for login is selected and displayed on the datalogger display. The language setting in the login window applies only to the current session. The language setting on the Web server software interface applies only to the current session after login. All automatic reports use the default language. Select the default operating language. All manual reports created on the Web server use the language for the current session.

PLANT STATUS

The main menu "Plant status" shows all the important information about the web server, connected devices and events that occur on the bus.

Plant status - System status

System status displays system information, event log and Web Access status information.

System information

The screenshot displays the Caleffi web interface. At the top, there is a green header with the Caleffi logo and the text 'Sistemi Calore'. Below the header, there is a navigation menu with options: 'Plant status', 'System status', 'Wired devices', 'Wireless devices', 'Inputs/Outputs', 'Settings', 'Export data', and 'User account'. The 'System status' option is selected. The main content area shows 'System info', 'Event log', and 'Web access' tabs. Under 'System info', there is a 'General status' section with the following information:

Internet connection :	OK	Plant name :	Palazzo Caleffi
Current IP address :	3.78.22.61	Serial number :	EV24036130
Web access status :	Reachable	Model :	DATA EASY PLUS
Wi-Fi status :	Not active	Address :	sr 229 n°10
Wi-Fi :	Enabled	Firmware version :	6.9_2.2_3.5
		Web interface version :	4.06

The following information is available in System Status:

- Internet connection: displays the current status of the Web server's Internet connection.
- Current IP address: displays the last public IP address of the datalogger.
- Web access status: displays the service status between online, offline, inactive
- Wi-Fi status: displays the Wi-Fi connection status
 - Disabled
 - Enabled: Time Remaining, SSID, Wi-Fi Address, MAC Address
- Wi-Fi: Button to enable or disable the datalogger Wi-Fi
- Plant name: name of the plant.
- Serial number: displays the serial number of the data logger.
- Model: displays the Web server type designation.
- Address: location of the plant.
- Firmware version: displays the firmware version installed on the web server.
- Web interface version: displays the installed version of the web user interface.

Plant status - Event log

Type	Start date	End date	Category	Reference	Description	Select
FTP	2025-06-15 23:00:03	-	FTP	FTP ID 98(1)	FTP - Report automatico	<input type="checkbox"/>
FTP	2025-06-15 23:00:03	2025-06-15 23:00:03	FTP	FTP ID 98	FTP - Report automatico	<input type="checkbox"/>
FTP	2025-06-14 23:00:04	2025-06-14 23:00:04	FTP	FTP ID 97	FTP - Report automatico	<input type="checkbox"/>
FTP	2025-06-14 23:00:03	2025-06-14 23:00:03	FTP	FTP ID 97	FTP - Report automatico	<input type="checkbox"/>
FTP	2025-06-13 23:00:03	-	FTP	FTP ID 96(1)	FTP - Report automatico	<input type="checkbox"/>
FTP	2025-06-13 23:00:03	2025-06-13 23:00:03	FTP	FTP ID 96	FTP - Report automatico	<input type="checkbox"/>
FTP	2025-06-12 23:00:05	2025-06-12 23:00:05	FTP	FTP ID 95	FTP - Report automatico	<input type="checkbox"/>
FTP	2025-06-12 23:00:03	2025-06-12 23:00:03	FTP	FTP ID 95	FTP - Report automatico	<input type="checkbox"/>
FTP	2025-06-11 23:00:03	-	FTP	FTP ID 94(1)	FTP - Report automatico	<input type="checkbox"/>
FTP	2025-06-11 23:00:03	2025-06-11 23:00:03	FTP	FTP ID 94	FTP - Report automatico	<input type="checkbox"/>
FTP	2025-06-10 23:00:03	2025-06-10 23:00:03	FTP	FTP ID 93	FTP - Report automatico	<input type="checkbox"/>
FTP	2025-06-10 23:00:03	2025-06-10 23:00:03	FTP	FTP ID 93	FTP - Report automatico	<input type="checkbox"/>
FTP	2025-06-09 23:00:03	-	FTP	FTP ID 92(1)	FTP - Report automatico	<input type="checkbox"/>

The "Event log" stores the following events:

- Alarms and warnings
- Change of status of inputs / outputs
- Send email status
- Send the status of the information via FTP

The following information can be read for each event:

- Type
- Start date
- End date
- Category
- Reference
- Description

YOU can view the following event statuses:

- Device OK: the alarms or alerts reported are correct.
- Device error: a device error is reported via M-Bus.
- Communication error: unable to communicate with the M-Bus device.
- Email sent successfully.
- Failed to send email (attempts made at 15 min intervals for 3 days).
- The read file was successfully transmitted to an FTP server.
- The file could not be transmitted to an FTP server (attempts made at 15 min intervals for 3 days).
- Status change recorded on an input.
- Status change recorded in output.

Simply set filters for each column to restrict search results to specific events.

The event log records up to 1000 events. The oldest event is removed after 1000 events.

You can delete individual rows in the event log or the entire list. Proceed as described below:

- Delete individual rows: check the box for the event you want to delete, then click "Delete events" at the top of the list. The (delete events) button is enabled if at least one row is selected.
- Delete full list: check the box "Select all" then "Delete events" to permanently delete the entire event log.

Note Check **Show only active events** to list only currently pending alarms and input/output status.

Click on a line to view the details of the event, e.g. the email sent including the attachment and the last data readings just before the error.

The screenshot shows the Caleffi web interface with a sidebar on the left containing 'Plant status', 'System status', 'Wired devices', 'Wireless devices', 'Inputs/Outputs', 'Settings', 'Export data', and 'User account'. The main area displays an event log table with columns for status, date, time, device name, and description. One event is highlighted in green, showing a 'Probe flow temp error' for device 'APP 10 P1' at 12:20:46 on 2025-05-14. Below this event, a detailed view shows device information: Device name (APP 10 P1), Scan interval (1 day), Description 1 (IDB 154), Install date (06/03/2025), Description 2 (A), Primary address (154), ID Device (24016795-0C2C0420), and Manufacturer code (CAL). A small image of the 'Conteca EASY' device is also shown. Below the details, a table shows the last readout timestamp as 2025-05-14 and a list of other events, including a 'Communication error' and several 'FTP - Report automatico' events.

Plant status - Web access

The screenshot shows the 'Web access' section of the Caleffi web interface. The sidebar is the same as in the previous screenshot. The main area has tabs for 'System info', 'Event log', and 'Web access'. Under 'Web access', there is a 'General status' section. It displays: Service status: Active (with a green dot icon and a 'Disable' button); Server status: Reachable (with a green dot icon); Web Access firmware version: SGH V: 3.3.0.2106011031; and Web server internet address: https://lev24036130.net.sghlot.com.

The following information is available in the Web access general status:

Service status: YOU can activate or disable the service

Server status: It displays whether the service is online or not

Web access firmware version: The firmware version of the datalogger Web access service is displayed

Web server internet address:The Internet address to reach the DATA EASY datalogger. Click on the address or type it in the address bar of the browser to connect to the DATA EASY using the Web access service.

Wired devices

The wired devices overview lists in abbreviated form all the M-Bus devices located on the bus.

Device Type	ID	Name	Address	Energy Consumption	Status
Heat	24101190	Appartamento 1 PR INTSX	B182 IDB 057	389 kWh	Warning
Heat	24101160	Appartamento 2 P1 INTSX	B182 IDB 055	1034 kWh	Warning
Heat	24101165	Appartamento 3 P1 INTDX	B182 IDB 061	2671 kWh	Warning
Heat	24101205	Appartamento 4 P2 INTSX	B182 IDB 058	1796 kWh	Warning
Heat	24101150	Appartamento 5 P2 INTDX	B182 IDB 059	980 kWh	Warning
Heat	24101180	Appartamento 6 P3 INTSX	B182 IDB 056	1687 kWh	Warning
Heat	24101135	Appartamento 7 P3 INTDX	B182 IDB 060	959 kWh	Warning
Heat	24042920	CT 51	B182 IDB 123	9750 kWh	Warning
Heat	24042925	CT 51.2	B182 IDB 121	1382 kWh	Warning
Heat	23488320	CT 51.3	B182 IDB 120	3257 kWh	Warning

You can read the following information for each row (per M-Bus device):

- Measured value
- Serial number (secondary address)
- Device image availability
- Device name (default is DEV_serial)
- Description: the bus to which the meter is connected
- Main value (editable, see section “Settings -> Wired devices”)
- Date and time of last reading
- Device status

The following device status can be displayed:

- ✓ Device OK
- ⚠ Device error
- 🚫 Communication error

Click on a line to list more information about the device

Communication status: OK Last readout timestamp: 2025/06/16 00:00:24 Read now

Device name	Appartamento 3 P1 INTDX	Scan interval	1 day
Description 1	IDB 061	Install date	27/08/2024
Description 2	A	Primary address	61
ID Device	24101165-0C2C0420	Manufacturer code	CAL
Medium	Heat		

▼ Last readout timestamp

User description	M-bus description	2025/06/16 00:00:24	2025/06/15 23:00:14	2025/06/15 00:00:24	2025/06/14 23:00:14	2025/06/14 00:00:24	2025/06/13 23:00:14
Bus address	Bus Address	61	61	61	61	61	61
Fabrication number	Fabrication Number	12345678	12345678	12345678	12345678	12345678	12345678
Heat energy	Energy	2671 kWh	2671 kWh	2671 kWh	2671 kWh	2671 kWh	2671 kWh

The information is grouped into three categories:

- Device information: general device data (name, description, ID, media, etc.)
- Last readout timestamp: displays the values of the last 6 readings.
- Alarm status: shows the faults on the device and which are recorded, sent by email, the type of event and the status.

Data points for viewing in detail can be predefined in the **Settings / Wired devices / Device settings** menu.

Click **Read now** to manually trigger a full reading of data from all devices

SETTINGS

Settings - System

System registry

The following system data can be assigned to the web server:

- Plant name
- Address
- Installer name
- Customer name
- Install date (today's date is set by default)

The screenshot shows the CALEFFI web interface for 'Sistemi Calore'. The 'System settings' tab is selected, displaying the following configuration fields:

- Plant name: Palazzo Caleffi
- Address: sr 229 n°10
- Installer name: Rossi Giuseppe
- Customer name: (empty)
- Install date: 2024-02-29

A 'Save' button is located at the bottom of the form.

Note **Changed** data must be confirmed with **Save**.

The name and address of the plant are displayed on the home page in the lower section to easily identify the web server, also before logging in.

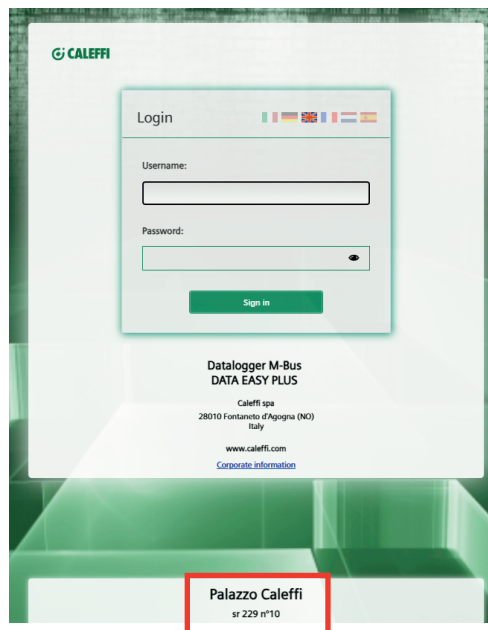

Alarms

As soon as the web server detects an alarm, it sends an alarm notification to the designated email address

Emails are sent only if the **Enable alarm notifications via email option is selected.**

The alarm notification can be sent simultaneously to multiple recipients. Multiple email addresses must be separated by a semicolon (;). The subject line of the email can be set individually to simplify sorting across multiple systems. Confirm with **Save**

System settings

The System settings tab has 4 areas:

System clock: You can automatically synchronise the system clock with your PC or enter it manually. Press **Set** to confirm

Report Settings: You can select whether to use a full stop or comma as a decimal separator. Press **Save** to make the setting effective.

System restart: You can remotely restart the web server by pressing the Reboot button.

Reset Access Code local display: By pressing the Reset button, it is possible to reset the access code for local access on the web server. For security reasons, immediately change the password locally on the web server after a reset.

IMPORTANT! The local access code cannot be entered remotely. You must visit the system.

Maintenance

The page is used to update the firmware of the DATA EASY web server

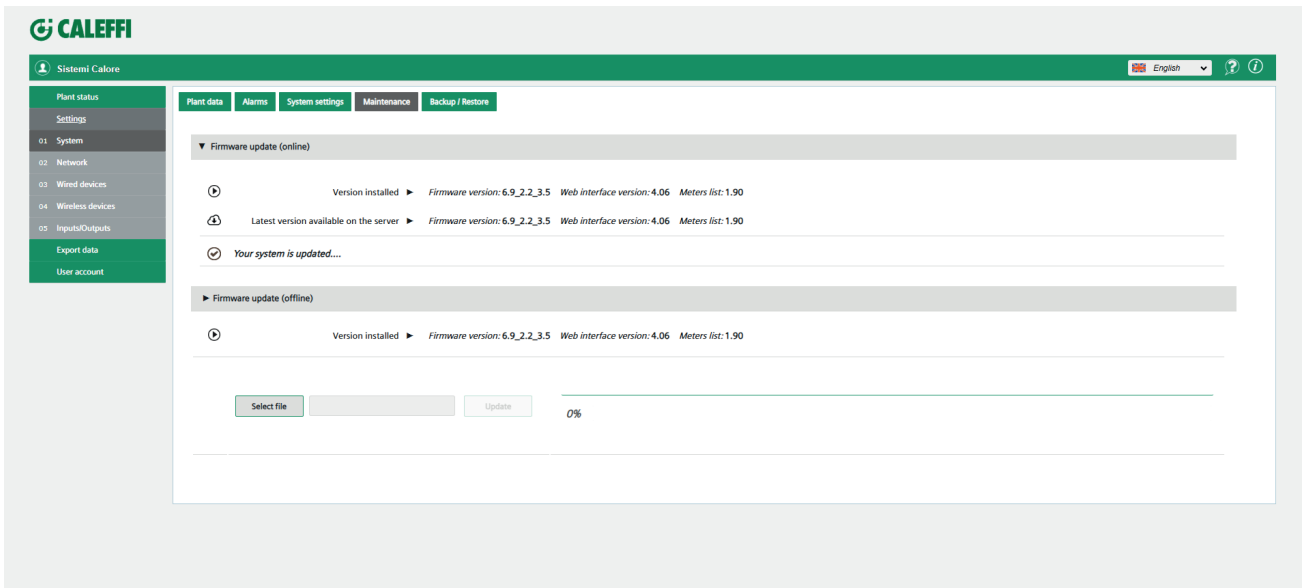

The firmware can be updated online or offline. The appropriate firmware can be installed directly from the Internet on the DATA EASY (online) or via PC (offline).

The web server restarts after the upgrade. The installation progress and reboot progress is displayed.

IMPORTANT! After a firmware update, all the data is available again. It is recommended to perform a backup and save the data to a PC before updating.

Backup / Restore

All data from the DATA EASY is backed up and restored on this page

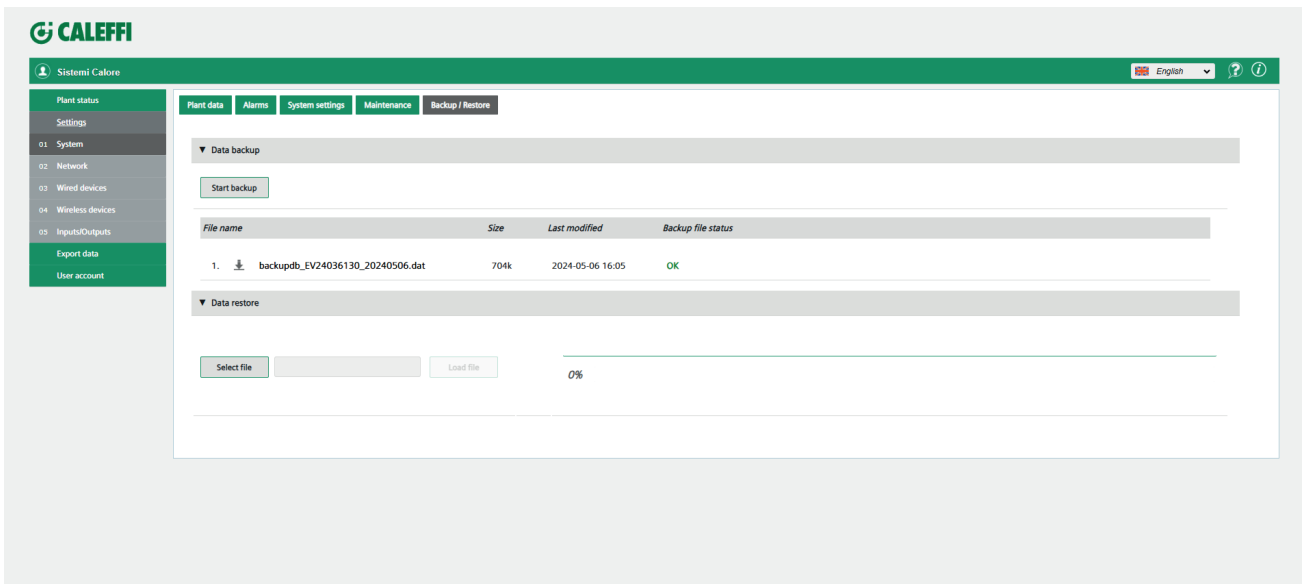

IMPORTANT! It is recommended to back up the web server data regularly.

Data backup

Pressing the **Start backup button** makes a backup of all the data and configurations of the DATA EASY.

The following information is displayed on each data backup:

- File name
- Size
- Last modified
- Backup file status

The backup file can be downloaded to the PC by clicking  or clicking the file name.

IMPORTANT! Always copy backup files to your PC. This is the only way to upload the backup file from a faulty web server to a new web server.

IMPORTANT! The backup file is encrypted. Device data cannot be altered.

Restoring data

To transmit a backup file to the web server, select the file (**Select file**) and install (**Upload file**).

The web server restarts after the upgrade. The installation progress and reboot progress is displayed.

IMPORTANT! The operation irretrievably removes all data and settings on the current web server. Therefore, it is recommended to back up current data before storing the data.

Settings - Network

Network settings

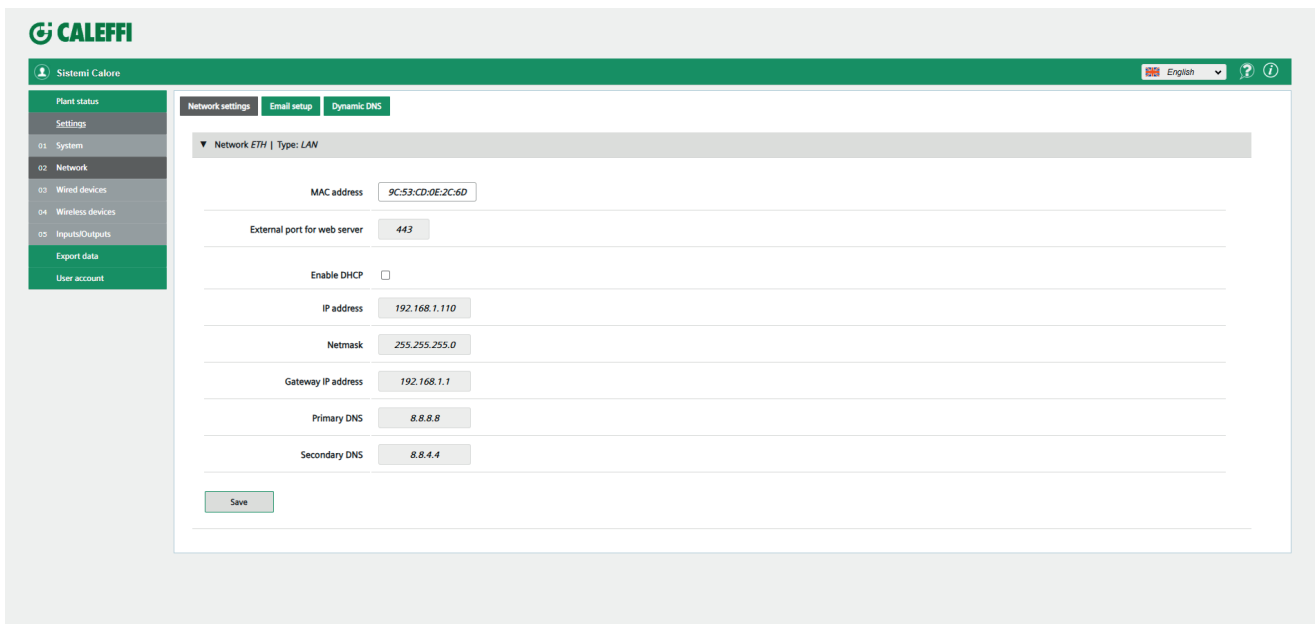

The screenshot shows the 'Network settings' page in the Caleffi web interface. The page title is 'Sistemi Calore' and the language is set to 'English'. The left sidebar contains navigation options: 'Plant status', 'Settings', '01 System', '02 Network', '03 Wired devices', '04 Wireless devices', '05 Inputs/Outputs', 'Export data', and 'User account'. The main content area is titled 'Network ETH | Type: LAN' and contains the following settings:

MAC address	9C:53:CD:0E:2C:6D
External port for web server	443
Enable DHCP	<input type="checkbox"/>
IP address	192.168.1.110
Netmask	255.255.255.0
Gateway IP address	192.168.1.1
Primary DNS	8.8.8.8
Secondary DNS	8.8.4.4

A 'Save' button is located at the bottom of the settings form.

The following information and settings are available:

- MAC address: shows the MAC address of the web server.
- External port for web server: This is only information from the external port used by DATA EASY. This external port number must be the same in the router's port forwarding settings.
- Enable DHCP: for the DHCP server (router) to automatically assign the IP address.
- IP address: if you assign a static IP address within the LAN.
- Netmask.
- Gateway IP address: IP address for the standard gateway (e.g. Router).
- Primary DNS: address of the main DNS name server (Domain Name System)
- Secondary DNS: secondary DNS name server address

Click **Save** to confirm the changes made to the above parameters.

IMPORTANT! Be careful when changing these settings! Ask your local network administrator for the required network configuration data

The web server is not suitable for direct connection to the Internet; it must be connected via a modem. This type of router typically has a firewall.

Email

The following data from your email server must be entered to forward the emails:

The screenshot shows the 'Email server settings' configuration page in the Caleffi web interface. The page is titled 'Email server settings' and contains the following fields:

- SMTP server name: smtp.caleffinet.com
- SMTP port: 25
- SMTP security: NO
- SMTP authentication:
- SMTP user name: data.easyplus@caleffinet.com
- SMTP password: [Redacted]
- Sender name: DataEasyPlus 750350
- Sender email address: data.easyplus@caleffinet.com

At the bottom of the settings section, there are 'Save' and 'Delete' buttons. Below the settings section, there is a 'Server connection test' section.

Email server settings

the following email server settings are available:

- SMTP server name: the address of the SMTP server.
- SMTP port: the port number used by the SMTP server.
- SMTP security: SSL or TLS security selection. The setting does not send emails without encryption; do not use this setting for security reasons.
- SMTP authentication: specify if the SMTP server requires authentication.
- SMTP user name: username for SMTP server access.
- SMTP password: password for SMTP server access.
- Sender name: name of the sender that appears in the email address (if your SMTP server allows it)
- Sender email address: the sender's custom email address (if your SMTP server allows it).

IMPORTANT! Be careful when changing these settings! Check with your email provider regarding the settings for the requested email servers.

Click **Save** to confirm the changes made to the above parameters.

Email server connection test

By clicking on **Server connection test**, you can verify the connection to the email server by sending a report to an email address of your choice. The results are displayed as soon as the message is sent:

The screenshot shows the 'Server connection test' result page. It displays the email address 'mail@mail.com' and a 'Server connection test' button with a green checkmark. Below this, a 'Test result' box contains the following message:

- Message has been sent successful using SMTP

Dynamic DNS

Dynamic DNS or DDNS (Dynamic DNS) is a service that allows you to associate a DNS name with the same public IP address of a host.

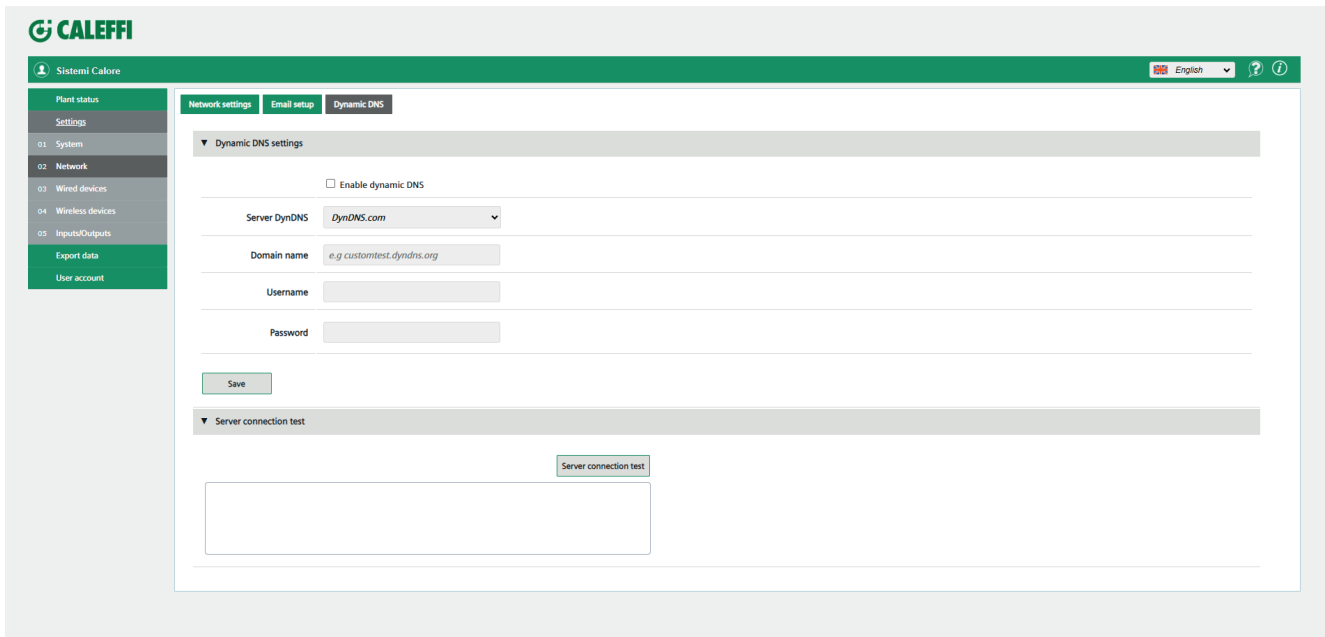

IMPORTANT! You must first set up an account with the provider to use the DynDNS or No-IP server.

Dynamic address report

The datalogger must inform the service of the changes to the dynamic IP address for it to communicate via the DynDNS service. Dynamic DNS must be set on the web server as follows:

- Enable dynamic DNS: allows the datalogger to use a dynamic DNS service
- Server DynDNS: the following two dynamic DNS providers are available:
 - No-IP.com
 - DynDNS.com
- Domain name: name provided by the dynamic DNS provider
- Username: username for dynamic DNS server access
- Password: user password for dynamic DNS server access

IMPORTANT! Be careful when changing these settings! Ask your network administrator for the required network configuration data.

Click Save to confirm the changes to the above parameters.

Connection test

The connection to the DynDNS server can be tested.

The results are displayed

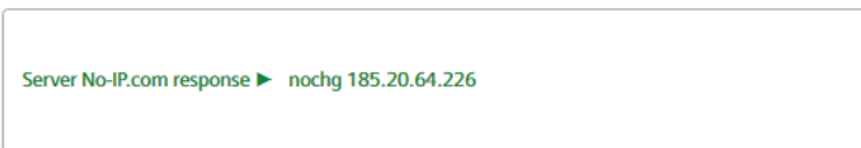

Settings - Wired devices

Meters setup

In this panel, you have access to the list of devices and can modify the settings.

Note The list is empty if no device search has been performed. The devices found and saved are displayed in the list after a device search.

The display is structured as follows:

1. List of all saved meters found on M-Bus lines connected in ABC or M1M2 line
2. Selected meter settings
3. Data point settings
4. Meter alarm settings

1. Saved meters list

Medium	M-Bus line	Serial number	Device name	Description	Manufacturer / Model	Scan interval	
Heat	B1B2	23488320	CT S1 3	IDB 120	Caleffi Conteca EASY	1 day	
Heat	B1B2	24042900	CT S1 4	IDB 122	Caleffi Conteca EASY	1 day	
Heat	B1B2	24042920	CT S1	IDB 123	Caleffi Conteca EASY	1 day	
Heat	B1B2	24042925	CT S1 2	IDB 121	Caleffi Conteca EASY	1 day	
Heat	B1B2	24101135	Appartamento 7 P3 INTDX	IDB 060	Caleffi Conteca EASY	1 day	
Heat	B1B2	24101150	Appartamento 5 P2 INTDX	IDB 059	Caleffi Conteca EASY	1 day	
Heat	B1B2	24101160	Appartamento 2 P1 INTSX	IDB 055	Caleffi Conteca EASY	1 day	
Heat	B1B2	24101165	Appartamento 3 P1 INTDX	IDB 061	Caleffi Conteca EASY	1 day	
Heat	B1B2	24101180	Appartamento 6 P3 INTSX	IDB 056	Caleffi Conteca EASY	1 day	
Heat	B1B2	24101190	Appartamento 1 PR INTSX	IDB 057	Caleffi Conteca EASY	1 day	
Heat	B1B2	24101205	Appartamento 4 P2 INTSX	IDB 058	Caleffi Conteca EASY	1 day	

The columns in the list are:

- Medium: Shows the measured medium of the meter
- M-Bus line: Shows on which line the saved meter was detected
- Serial number: Shows the meter serial number
- Device name: Displays the meter name entered under the device name
- Description: Shows the text entered in Description 1
- Indicates that a product image is available for the device.
- Manufacturer / Model: Displays the 3-letter code of the device manufacturer if it is not already integrated into the "Presetting meter list" (readable meter but not preconfigured for reports). Otherwise, it indicates the Manufacturer in full and the M-Bus device model.
- Scan interval: Indicates the frequency with which the datalogger automatically queries the M-Bus meter to receive the data.
- Trend report: Indicates whether the device has been configured at least one datapoint such that it is included in the "Trend Report".
- Delete: Click the trash can to delete the device from the list.

The list of wired devices can be exported as .xls or .csv files. Click on the corresponding symbol:



Serial number	Device name (X)	Description (X)	Manufacturer code	Medium	M-Bus line
6129250	DEV_06129250	PA_000	SMC	Water	M1M2
6129251	DEV_06129251	PA_000	SMC	Warm Water	M1M2
7964864	DEV_07964864	PA_000	LSE	Heat/Cooling	M1M2
10485501	DEV_10485501	PA_001	REL	Water	M1M2
10485502	DEV_10485502	PA_002	REL	Warm Water	M1M2
15550082	DEV_15550082	PA_000	MAD	Water	M1M2
23282974	DEV_23282974	PA_000	EFE	Heat	M1M2
66091674	DEV_66091674	PA_157	LUG	Heat	M1M2
66336640	DEV_66336640	PA_003	LUG	Heat	M1M2

2. Selected meter settings

Click on the device line to view the setting for the device

Device name	<input type="text" value="CT 51 2"/>	(**) Scan interval	<input type="text" value="1 day"/>	 <p>Caleffi</p> <p>Conteca EASY</p>
Description 1	<input type="text" value="IDB 121"/>	Install date	<input type="text" value="27/08/2024"/>	
Description 2	<input type="text" value="CT"/>	Primary address	<input type="text" value="121"/>	
ID Device	<input type="text" value="24042925-0C2C0420"/>	Baudrate	<input type="text" value="9600"/>	
Read by	<input type="text" value="Primary address"/>	Manufacturer code	<input type="text" value="CAL"/>	
Medium	<input type="text" value="Heat"/>	Version (HEX)	<input type="text" value="20"/>	

Free text settings:

- Device name: you can assign a name to the device (e.g. Apartment 123).
- Description 1: description of the device as indicated in the list of devices.
- Description 2: additional description
- Scan interval: 15 min. / 60 min., 6 h, 12 h, 1 day, 7 days, 1 month
- Install date: you can add an installation date
- The device image can be set by clicking on  as needed. You can select the appropriate image from the datalogger device database.

Click **Save** to save the changed values.

Settings that cannot be changed:

- ID Device: Shows the meter serial number
- Read by: Displays whether the meter is read via the primary address or the secondary address.
- Medium: Displays the medium measured by the device.
- Primary address: Displays the primary address of the device (1 ... 250)
- Baudrate: Displays the transmission speed between the device and the datalogger.
- Manufacturer code: Displays the manufacturer's code.
- Version (HEX): Displays the device version.

3. Data points settings

Main Value	User description	M-bus description	Standard Report - Data point mapping	Custom Report - Data point to be included	...
<input type="radio"/>	<input type="text" value="Bus address"/>	Bus Address	none	<input checked="" type="checkbox"/>	...
<input type="radio"/>	<input type="text" value="Fabrication number"/>	Fabrication Number	fabrication_number	<input checked="" type="checkbox"/>	...
<input checked="" type="radio"/>	<input type="text" value="Heat energy"/>	Energy	heat_energy	<input checked="" type="checkbox"/>	...
<input type="radio"/>	<input type="text" value="Current power"/>	Power	none	<input checked="" type="checkbox"/>	...
<input type="radio"/>	<input type="text" value="Flowrate"/>	Volume Flow	none	<input checked="" type="checkbox"/>	...
<input type="radio"/>	<input type="text" value="Flow temperature"/>	Flow Temperature	none	<input checked="" type="checkbox"/>	...
<input type="radio"/>	<input type="text" value="Return temperature"/>	Return Temperature	none	<input checked="" type="checkbox"/>	...
<input type="radio"/>	<input type="text" value="Temperature difference"/>	Temperature Difference	none	<input type="checkbox"/>	...
<input type="radio"/>	<input type="text" value="Device date time"/>	Time Point	device_date_time	<input checked="" type="checkbox"/>	...
<input type="radio"/>	<input type="text" value="Firmware version"/>	Firmware Version	none	<input checked="" type="checkbox"/>	...
<input type="radio"/>	<input type="text" value="Software version"/>	Software Version	none	<input checked="" type="checkbox"/>	...
<input type="radio"/>	<input type="text" value="Volume CO"/>	Volume	none	<input type="checkbox"/>	...
<input type="radio"/>	<input type="text" value="1st pulse input"/>	Volume	aux1_volume	<input checked="" type="checkbox"/>	...
<input type="radio"/>	<input type="text" value="2nd pulse input"/>	Volume	aux2_volume	<input checked="" type="checkbox"/>	...
<input type="radio"/>	<input type="text" value="3rd pulse input"/>	Volume	aux3_volume	<input checked="" type="checkbox"/>	...
<input type="radio"/>	<input type="text" value="4th pulse input"/>	Volume	none	<input checked="" type="checkbox"/>	...
<input type="radio"/>	<input type="text" value="Cooling energy"/>	Energy	cool_Energy	<input checked="" type="checkbox"/>	...
<input type="radio"/>	<input type="text" value="Manufacturer data"/>	specific data struct	none	<input type="checkbox"/>	...

- Main Value: You can select the value for display in the **Plant status -> Wired devices** overview
- User description: the designation of the data point can be changed
- M-bus description: designation of the data point according to the M-Bus specification
- Standard Report – Data point mapping: assign data points to predefined columns in the standard report. Only one data point can be assigned to a specific column for each device. Data points with the settings “none” are not displayed in the standard report
- Custom Report – Data point to be included: select the data points to be included in the custom report. This report includes only the data points selected in the relevant column.
- Trend Report – Data point to be included: select the data points to be included in the trend report. This report includes only the data points selected in the relevant column.
- "...": Click on the "..." column to display further details (Multiplier, Storage, Subunit, Tariff, Type Value and Units) on the selected data point. Details can help you provide a meaningful user description

Heat energy		Energy	heat_energy	<input checked="" type="checkbox"/>	...
Subunit	0				
Storage	0				
Tariff	0				
Type value	Instantaneous Value				
Multiplier	1				
Units	kWh				
UUID	33d03335-4c13-377a-bef7-5605b884505f				
MBTAG	EW1!				
REP_ID_OMS	3				
DIB	0406				
OBIS	6-0:1.0.0-255				

Click **Save** to save the changed settings.

4. Meter alarm settings

For each device you can view a series of error messages that are available through M-Bus.

The following information and settings are available.

- LOG: When an error occurs, it displays whether the message is logged in the event log.
- Email: When an error occurs, it displays if an email is sent with the error message.
- Event name: The event name is set by default. However, it can be changed as needed.
- Event type: Displays the type of event received by the device.
- Status: Displays whether the alarm is active or not.

LOG	Email	Event name	Event type	Status	...
<input checked="" type="checkbox"/>	<input checked="" type="checkbox"/>	Probe flow temp error	M-bus status notification	Active	...
<input checked="" type="checkbox"/>	<input checked="" type="checkbox"/>	Probe return temp error	M-bus status notification	Not active	...

Actions	<input checked="" type="checkbox"/> Add to log	<input checked="" type="checkbox"/> Send email														
Input condition	Bit 15 <input type="checkbox"/>	Bit 14 <input type="checkbox"/>	Bit 13 <input type="checkbox"/>	Bit 12 <input type="checkbox"/>	Bit 11 <input type="checkbox"/>	Bit 10 <input type="checkbox"/>	Bit 9 <input type="checkbox"/>	Bit 8 <input type="checkbox"/>	Bit 7 <input type="checkbox"/>	Bit 6 <input type="checkbox"/>	Bit 5 <input type="checkbox"/>	Bit 4 <input type="checkbox"/>	Bit 3 <input type="checkbox"/>	Bit 2 <input type="checkbox"/>	Bit 1 <input checked="" type="checkbox"/>	Bit 0 <input type="checkbox"/>

Click "..." to open a new panel with the following settings:

- Actions:
 - Add to log: Select if it is added to the event log when this alarm occurs.
 - Send email: Select whether to send an email notification when this alarm occurs.
- Input condition:

You can select for the device the bit from the M-Bus status byte that represents the corresponding alarm notification.

Click **Save** to apply alarm settings. You must confirm to apply settings!

By selecting the check box, if multiple devices of the same type are installed on the system, it is possible to transfer the identified settings from (**) onto all devices of the same type.

Save

Select this option to apply the settings marked with (**) to all devices of the same brand and model

Device Search - M-Bus line M1M2 / M-Bus line ABC / M-Bus line B1B2

You can search for the device individually on the M1M2 line or the ABC line respectively or search for both lines in parallel. For device searches, you can select whether to use the default settings or search based on specific criteria

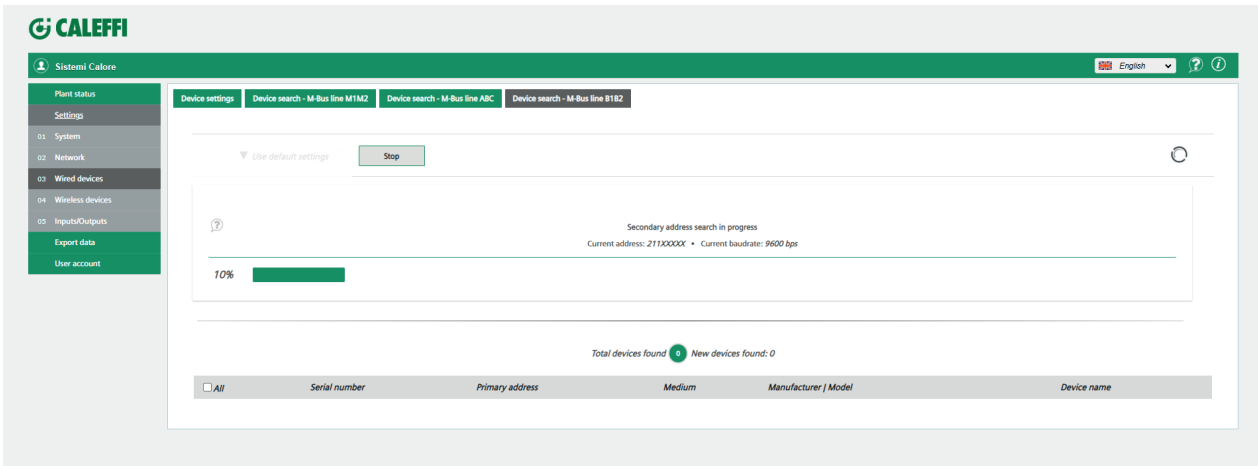

The entire bus is scanned for the connected M-Bus devices if you select **Use default settings** and click **Start scan**.

Note Start by scanning with **Use default settings**. Use the custom device search only if the Use default settings search does not recognise one or more devices. This can happen if a data collision occurs on the bus during automatic search or if the device does not operate at the standard baudrate. Refer to the device documentation for the data. Using the default setting, the web server searches for devices based on the secondary address at a transmission speed of 9600 bps.

Custom search: - M-Bus line M1M2 / RS485 line B1B2

By unchecking **Use default settings**, you can customise the search type for devices on the bus

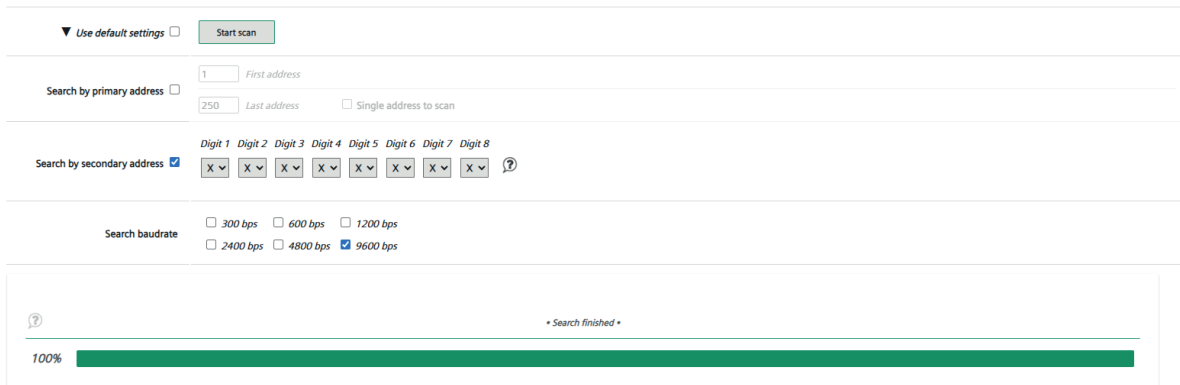

You can customise a search according to the following criteria:

- Primary address
- Secondary address (serial number)
- Baudrate

Search by primary address:

You can select or clear a search by primary address.

- First address: You can define the starting address for the search
- Last address: You can define the final address for the search
- Single address to scan: By checking this option, a specific primary address can be scanned.

Search by secondary address:

You can select or clear a search by secondary address (serial number).

To shorten the search time, you can limit the search range for secondary addresses by using the Digit 1 to Digit 8 settings.

Search baudrate:

You can enter the corresponding baudrate for the device search if the devices deviate from the default transmission speed (please refer to the device documentation for the transmission speed). You can search for devices based on a specific transmission rate (300/600/1200/2400/4800/9600 bps). Multiple baudrates can also be selected. The search for the device takes longer if multiple transmission speeds are selected at the same time.

Click **Start scan**.

The progress is indicated by the progress bar.

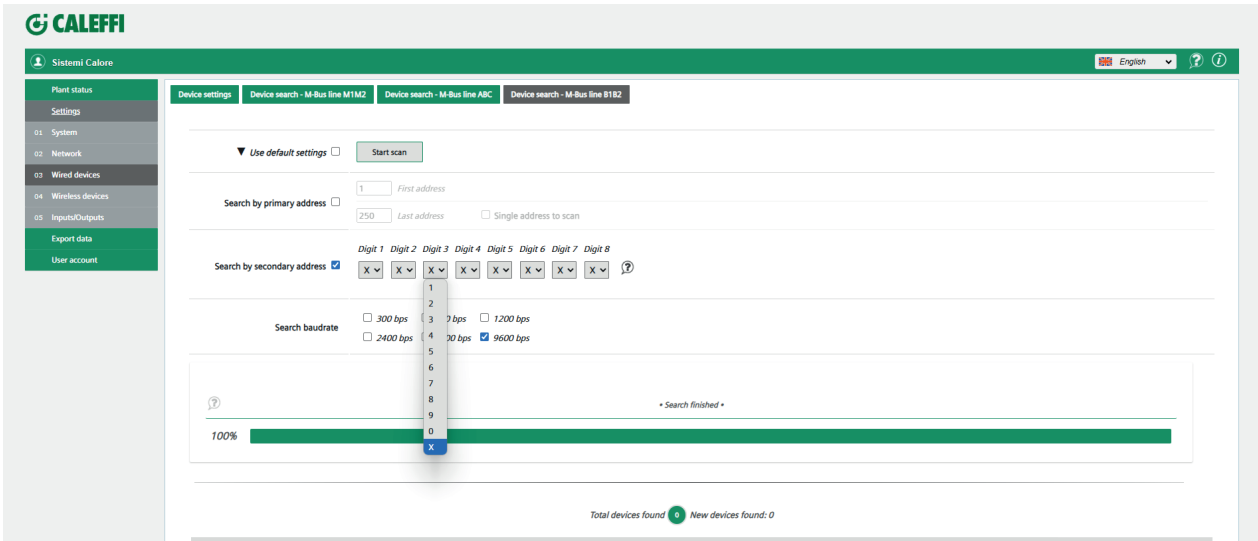

Search results:

All devices found are listed at the end of the device search. Select one or more devices and press Add, to add the new devices to the list of devices.

IMPORTANT! Devices that are not saved are discarded

The following is the minimum information displayed for each device found:

- Serial number
- Primary address
- Measured medium
- Manufacturer code with device image, optional
- Automatically generated device name.

Export data

The data recorded by the web server can be exported as reports for further processing.

There are two ways to create a report:

- Manual reports
- Automatic reports

EXPORT DATA

The data recorded by the web server can be exported as reports for further processing. There are two ways to create a report:

- Manual reports
- Automatic reports

Export data - Manual reports:

Creating a report

The meters for which you want a report must be selected. Wired models must be read before creating a report, otherwise, as with wireless meters, the last saved data will be available with a time interval as per the setting (see the paragraphs Meter setup and **Error. Reference source not found.** for wired and wireless devices respectively). Click **Read now** to read the devices in the list.

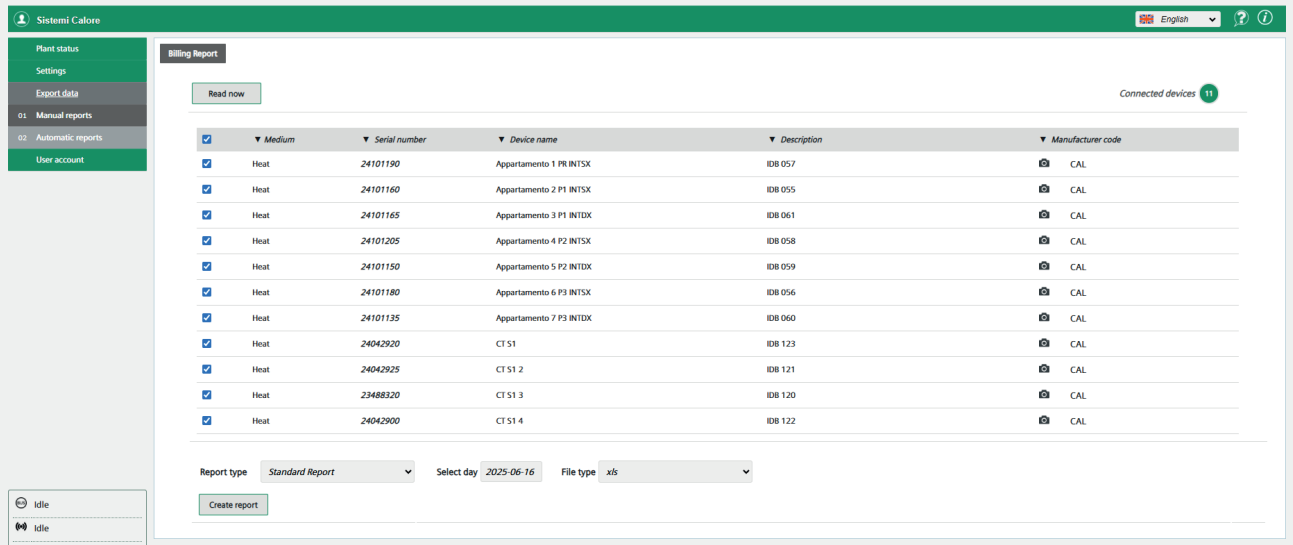

Select the devices to be included in the report. Select the checkbox in the title line to select all devices in the list.

<input checked="" type="checkbox"/>	▼ Medium	▼ Serial number	▼ Device name	▼ Description	▼ Manufacturer code
<input checked="" type="checkbox"/>	Heat	24101190	Appartamento 1 PR INTSX	IDB 057	CAL
<input checked="" type="checkbox"/>	Heat	24101160	Appartamento 2 P1 INTSX	IDB 055	CAL
<input checked="" type="checkbox"/>	Heat	24101165	Appartamento 3 P1 INTDX	IDB 061	CAL
<input checked="" type="checkbox"/>	Heat	24101205	Appartamento 4 P2 INTSX	IDB 058	CAL
<input checked="" type="checkbox"/>	Heat	24101150	Appartamento 5 P2 INTDX	IDB 059	CAL
<input checked="" type="checkbox"/>	Heat	24101180	Appartamento 6 P3 INTSX	IDB 056	CAL
<input checked="" type="checkbox"/>	Heat	24101135	Appartamento 7 P3 INTDX	IDB 060	CAL
<input checked="" type="checkbox"/>	Heat	24042920	CT S1	IDB 123	CAL
<input checked="" type="checkbox"/>	Heat	24042925	CT S1 2	IDB 121	CAL
<input checked="" type="checkbox"/>	Heat	23488320	CT S1 3	IDB 120	CAL
<input checked="" type="checkbox"/>	Heat	24042900	CT S1 4	IDB 122	CAL

Note To make it easier to find your device, you can sort the list in alphabetical order by clicking ▼.

Before generating the report, it is necessary to make the following selections:

- Report type (select from):
 - Standard Report: This report includes only data points on devices that have been assigned a standard column in the device settings (see Data points settings).

Report type **Standard Report** ▼ Select day **2025-07-16** File type **xls** ▼

- Custom Report: This report includes only the data points on the devices selected in the “Custom Report – Data point to be included” column in the device settings (see Data point settings).

Report type **Custom Report** ▼ Select day **2025-07-16** File type **xls** ▼

- All Data Report: This report includes all data points from all devices.

Report type **All Data Report** ▼ Select day **2025-07-16** File type **xls** ▼

For the report templates described above, other options are also displayed:

- Select day: select the data reading date for the devices used for the report. The current date is always the default date. You can also select a date in the past.
- File type: select one of the following file formats:
 - .csv: export the data as a .csv file.
 - .xls: export the data as an .xls file.
 - .txt: export the data as a .txt file.

Export data - Automatic reports

Read and post now: immediately read all the devices in the summary list and send the data according to the following settings.

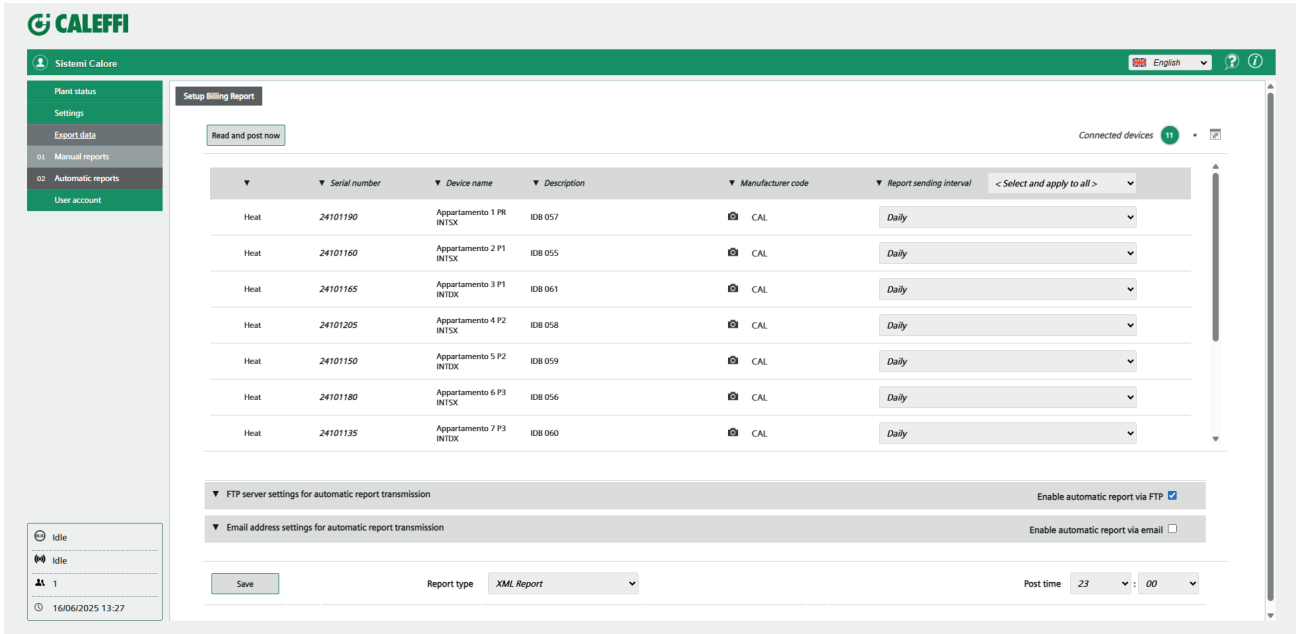

The following data is available on each device:

- Measured medium
- Serial number
- Device name
- Description
- Manufacturer code
- Report sending interval

Report sending interval

Select the interval for report generation.

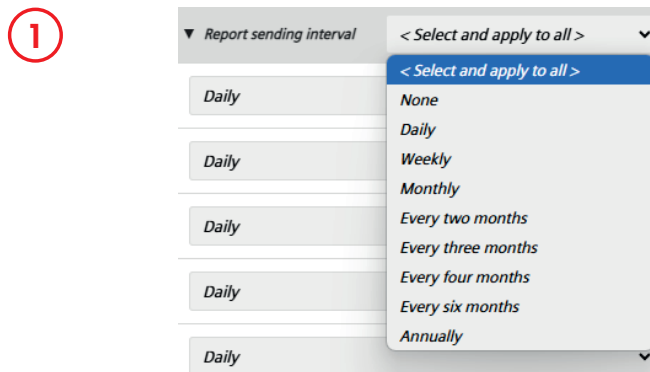

The following options are available:

- Disable: no report generated.
- Daily: the report is generated daily at the following the previous 24 hours.
- Weekly: the report is generated on Monday following the previous week.
- Monthly: the report is generated at the end of the last day of the month.
- Every two months: the report is generated at the end of the last day of the bimonthly period.
- Every three months: the report is generated at the end of the last day of the quarter.
- Every four months: the report is generated at the end of the last day of the quarter.
- Every six months: the report is generated at the end of the last day of the six-month period.
- Annually: the report is generated at the end of the last day of the year.

Selecting a reading range in the title bar applies the setting to all devices in the list.

Click **Save** to save the entries.

Report sending interval

Select the interval for report generation.

2

▼ FTP server settings for automatic report transmission Enable automatic report via FTP

FTP server name:

Remote path:

FTP server port:

FTP protocol:

Username:

Password:

- FTP server name: Enter the address for the FTP server
- Remote path: It is possible to enter a path on the FTP server to save the reports
- FTP server port: Enter the port for the FTP server
- FTP protocol: select the FTP protocol. The following protocols are available:
 - SFTP – File Transfer Protocol (SSH)
 - FTP – File Transfer Protocol (TLS)
 - FTP – No encryption (not secure)
- It is not recommended to use "unencrypted FTP" for security reasons
- Username: Enter the username to access the FTP server
- Password: Enter the password to access the FTP server

Click **Server connection test** to test the connection to the FTP server. The file ftp_test_connection.txt is saved to the FTP server.

Click **Save** to save the entries.

Email address settings for automatic report transmission

Select "Enable automatic report via email" to send a report to one or more email addresses and enter the corresponding email addresses, including the subject

3

▼ Email address settings for automatic report transmission Enable automatic report via email

To:

Cc:

Bcc:

Subject:

- A: To. You can separate individual addresses with a semicolon (;) if a report is sent to multiple addresses.
- Cc: Carbon copy
- Bcc: Blind carbon copy
- Subject: Subject of the email

Click **Save** to save the entries.

Type of report selection

Before saving the automatic report settings, you can choose the type of report to receive:

- Standard Report: this report only includes data points from devices that have been assigned a column in the "Standard Report - Data point mapping" in the device settings (see Data point settings).

Report type: File type: Post time: :

- Custom Report: this report includes only the data points from the devices selected in the "Custom Report – Data point to be included" column in the device settings (see Data point settings).

Report type: File type: Post time: :

- All Data Report: this report includes all data points from all devices.

Report type: File type: Post time: :

For the report templates described above, other options are also displayed:

- Post time: select the report submission time.
- File type: select one of the following file formats (*):
 - .csv: export the data as a .csv file.
 - .xls: export the data as an .xls file.
 - .txt: export the data as a .txt file.

Standard Report

The standard report lists all the devices read. A device corresponds to a row. Each column is the same for each device. The corresponding column is empty if a device has not assigned a certain value. The columns must be assigned to the corresponding data point in the device settings in the column "Standard Report - Data point mapping" see Data point settings.

File Name	Report Date	Report Time	Plant Reference	Firmware version	Total devices cabled	Total devices wireless	Serial Number					
FC_report_EV12345678_AAAA-MM-DD.xls	DD/MM/AAAA	HH:mm:ss	Plant Address	x.yz x1.y1_x2.y2_x3.y3 k	0		EV12345678					
count	primary_address	device_serial_number	name_device	device_description	device_detail	device_measure_hex	0=wired 1=wireless	model_id	readout_date	readout_time	communication_status	

Custom Report

A custom report displays each device with two rows: the first row describes the content and the second row describes the corresponding values. The number of columns varies depending on the device and the data points selected. Only the data points selected in the "Custom Report - Data point to be included" column in device settings are listed, see Data point settings.

File Name	Report Date	Report Time	Plant Reference	Firmware version	Total devices cabled	Total devices wireless	Serial Number									
CUST_report_DD/MM/AA#HH:mm:ss	DD/MM/AAAA	HH:mm:ss	Sinapsi_12	x.yz x1.y1_x k	0		EV12345678									
count	primary_add	device_serial	name_device	device_desc	device_detail	device_meas	0=wired 1=v	model_id	readout_date	readout_time	communication	col 1	col 2	col 3	col 4	...

All Data Report

All Data Report displays each device with two rows: the first row describes the content and the second row the corresponding values. The number of columns varies for each device based on the device type. All the data points that can be read are listed.

File Name	Report Date	Report Time	Plant Reference	Firmware version	Total devices cabled	Total devices wireless	Serial Number									
raw_report_EV12345678_AAAA-MM-DD.csv	DD/MM/AAAA	HH:mm:ss	Sinapsi_12	x.yz x1.y1_x2.y2_x3.y3 k	0		EV12345678									
count	primary_address	device_serial_number	name_device	device_description	device_detail	device_measure_hex	0=wired 1=wireless	model_id	readout_date	readout_time	communication	col 1	col 2	col 3	col 4	...

For the report templates described above, other options are also displayed:

- Post time: select the report submission time.
- File type: select one of the following file formats (*):
 - .csv: export the data as a .csv file.
 - .xls: export the data as an .xls file.
 - .txt: export the data as a .txt file.

Note The number in the reports is represented as follows:

- Point as decimal point separator

XML Report

The XML Report lists all read intervals in the first column. A data point on a device corresponds to a column. If there are multiple data points for the same device, the corresponding readings will be set to multiple columns. The corresponding range-column paired cell is empty if a device in that range has no data. In fact, in the rows in the first column of the report the shortest time interval is shown, where the reading intervals are different for the data points of the selected devices. Columns must be assigned to the corresponding data point in the device settings in the column "Trend Report - Data point to be included" - see Data point settings.

USER ACCOUNT:

The User account menu shows all registered users and creates a new user. In addition, all login attempts (User Access Logging) are logged. From this section it is also possible to generate the "API Authorization Key", i.e. the useful key for operating the RTUEVO RESTful API.

Click **Exit** to disconnect from the web server.

User account - Account configuration

New User

New User creates a new user account on the web server.

At the same time, it provides information about all previously registered users, including access rights (User Type).

First name	<input type="text"/>	Last name	<input type="text"/>
* Email	<input type="text"/>	* Username	<input type="text" value="admin"/>
* Password	<input type="password" value="*****"/>	* Confirm password	<input type="password"/>
* User Type	Administrator <input type="button" value="Strong"/>		
User configuration <input type="button" value="Add"/>			

You must be logged in as an administrator to edit user data or create a new user.

First name Last name
 * Email * Username
 * Password * Confirm password Good
 * User Type Administrator
 User configuration

Enter the new user data and click **Add**:

- First name
- Last name
- Email
- Username
- Password
- Confirm password
- User Type:
 - User: Users have a limited view on the web server and cannot edit or enter settings.
 - Maintenance technician: Maintenance technicians have a limited view on the web server. They can change or enter some settings with respect to users.
 - Administrator: Administrators have access to all data and functions.

MENU	Administrator	Maintenance technician	User
System status	A	L	L
Settings	A	L	-
Export data	A	A	A
User account	A	-	-

A: Unlimited access

L: Limited access

-: No access

If you are an administrator in this section you can also manage the previously registered accounts. You can edit the data and save the changes made and change the type of access for each account.

New user Users Access Logging

Username	First name Last name	User Type	Email
caleffidivele	Sistemi Calore	Administrator	sistemi.calore@caleffi.com

First name Last name
 * Email * Username
 * Old password
 * Password * Confirm password
 * User Type Administrator

API Authorization Key Endless (∞) 📄 ... ✖

User configuration

It is also possible to view and generate the "API Authorization Key" for Administrator accounts. For more information on how to use the APIs, refer to the paragraph **Error. Reference source not found.**

User Access Logging

All access actions are recorded on the web server.

Last Login	Logged	User	User Type	IP
2025-06-16 13:01:23	Connected	Sistemi Calore (caleffidivele)		10.8.0.1
2025-06-12 16:09:20	Not Connected	Sistemi Calore (caleffidivele)	Administrator	10.8.0.1
2025-05-28 08:38:08	Not Connected	Sistemi Calore (caleffidivele)	Administrator	10.8.0.1

The following information is retained for each access:

- Last Login: Date and time when the user logged in.
- Logged: User status.
- User: Name and surname of the user.
- User Type: Administrator / Maintenance technician / User.
- IP: IP address of the PC used by the user to access the web server.
- User access data is recorded for the last 28 days.

Disconnect

Click **Exit** to disconnect from the web server without further warning.

APPENDIX

Information on licences

The licence texts of all Open Source software packages can be viewed individually on 

Third-Party Software Information







Warranty regarding further use of the Open Source Software:

License name	Size	Last Modified
1 ▶ Apache 2.0	11k	December 19, 2004
2 ▶ Artistic	6k	December 16, 1996
3 ▶ BSD	1k	August 26, 1999
4 ▶ GFDL-1.2	20k	March 24, 2010
5 ▶ GFDL-1.3	22k	November 03, 2008
6 ▶ GPL-1	12k	March 24, 2010
7 ▶ GPL-2	18k	March 24, 2010
8 ▶ GPL-3	34k	July 02, 2007
9 ▶ LGPL-2.1	26k	March 24, 2010
10 ▶ LGPL-2	25k	March 25, 2010
11 ▶ LGPL-3	7k	March 24, 2010

Package name	Size	Last Modified	Update
1 ▶ adduser	2k	May 15, 2012	
2 ▶ atit	1k	October 23, 2014	
3 ▶ base-files	1k	August 30, 2015	
4 ▶ base-passwd	1k	August 02, 2010	
5 ▶ bash	19k	September 25, 2014	

Tools for updating packages

All packages subject to GPL-3 or LGPL-3 licensing must be made upgradeable to experienced users for legal licensing reasons. Packages are labelled in the list with 

6 ▶ binutils	2k	January 05, 2015	
7 ▶ bsdutils	1k	December 11, 2012	
8 ▶ ca-certificates	18k	September 24, 2014	
9 ▶ coreutils	12k	January 26, 2013	
10 ▶ cpio	1k	December 22, 2014	
11 ▶ cron	4k	July 03, 2012	
12 ▶ dash	3k	March 01, 2012	
13 ▶ dbus	11k	February 05, 2015	
14 ▶ debconf-i18n	3k	September 11, 2012	
15 ▶ debconf	3k	September 11, 2012	
16 ▶ debian-archive-keyring	1k	November 21, 2006	
17 ▶ debiutils	8k	June 28, 2012	
18 ▶ dialog	1k	March 03, 2012	
19 ▶ diffutils	2k	October 16, 2011	

Caleffi regularly provides firmware updates to the web server. This occurs exclusively through firmware updates (online or offline). The package update tool is not required for the operation and maintenance of the web server.

IMPORTANT! THE web server can no longer be used as an M-Bus master as soon as a package is modified with this tool!

Access to the web server via web operation and local operation is no longer possible! All data is deleted on the web server for security reasons! This procedure can no longer be cancelled and a new web server must be purchased if the tool is accidentally used to update a package! Only the basic Linux system remains on the device after completing a package update.

The device can be accessed via an SSH connection via Ethernet port 192.168.1.110. Use root username and password **12345678**.

Manufactured by

SINAPSI S.R.L.

Via delle Querce 11/13
IT - 6083 Bastia Umbra (PG)

TELTONIKA NETWORKS UAB

K. Barsausko st. 66
LT - 51436 Kaunas, Lithuania

