

Automatic charging and demineralisation unit



© Copyright 2021 Caleffi

580 - 5709 series

Function

The charging and demineralisation unit is used for automatically filling the closed circuits and for water treatment of heating and cooling systems, with backflow prevention in accordance with EN 1717.

Demineralised water has low electrical conductivity and a slightly basic pH, making it ideal for preventing corrosion and the build-up of limescale deposits in the circuit.

The unit comprises shut-off valves with an inspectable strainer, a BA type controllable backflow preventer, a pre-adjustable filling unit, a volume meter. It is also complete with water treatment cartridge and pre-formed shell insulation.

Product range

580
5709



580022 Automatic charging and demineralisation unit complete with disposable cartridge, content 0,75 l.

580023 Automatic charging and demineralisation unit complete with disposable cartridge, content 1,5 l.

570925 Color changing resin demineralization cartridge, content 0,75 l.

570926 Color changing resin demineralization cartridge, content 1,5 l.

Technical specifications

Materials

Backflow preventer

Body: brass EN 12165 CW617N
 Check valves: POM-EPDM
 Springs: stainless steel EN 10270-3 (AISI 302)
 Diaphragm and seals: EPDM

Filling unit

Body: brass EN 12165 CW617N
 Cover: PA6G30
 Obturator control stem: dezincification resistant alloy **CR** EN 12164 CW724R
 Diaphragm and seals: EPDM

Shut-off ball valve

Body: brass EN 12165 CW617N
 Ball: dezincification-resistant alloy **CR** EN 12164 CW724R
 Hydraulic seals: EPDM
 Lever handle: PA6G30

Strainer

Body: stainless steel EN 10088-2 (AISI 304L)
 Internal filter mesh Ø: 0,4 mm

Insulation

Material: EPP
 Density: 30 kg/m³

Disposable cartridge

Housing: polymer
 Contents: mixed bed ion exchange resins

Performances

Medium: Water
 Maximum working temperature: 65 °C
 Maximum working pressure: 10 bar
 Connections: 1/2"

Backflow preventer

Designation: Family B, Type A
 Certification: EN 12729
 Pressure ports: upstream, intermediate, downstream

Filling unit

Set pressure range: 0,8–4 bar
 Factory set: 1,5 bar
 Indicator accuracy: ± 0,15 bar
 Pressure gauge range: 0–4 bar

Disposable cartridge

Nominal flow rate: 50 l/h
 Maximum working pressure: 8 bar
 Working temperature range: 4–30°C
 Storage temperature range: 0–40°C
 Hardness of water after treatment: 5°f / 3°dH
 Electrical conductivity after treatment: < 30 µS/cm
 Connections: 1/2"

Do not expose to UV radiation.

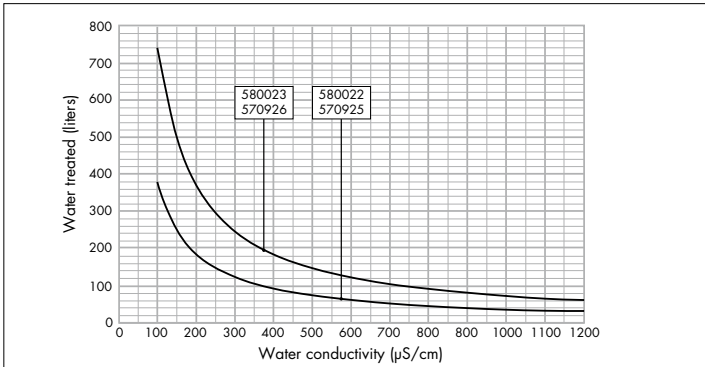
Capacity of the cartridge

	580022	580023
330 µS/cm	113 liters	225 liters
500 µS/cm	74 liters	149 liters
12°dH / 21°F (*)	94 liters	188 liters
20°dH / 36°F (*)	56 liters	113 liters

(*) Values only applies for untreated raw water. Not valid for softened water.

Characteristic components

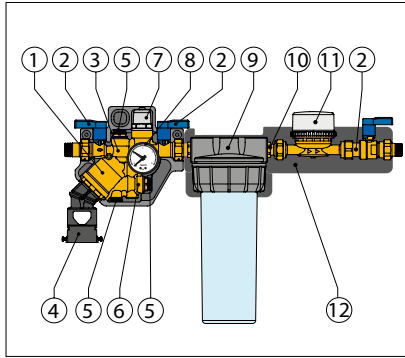

- 1 BA type controllable backflow preventer
- 2 Ball shut-off valve
- 3 Inspectable strainer
- 4 Drain tundish
- 5 Pressure test ports
- 6 Inspectable downstream check valve
- 7 Pressure reducing valve
- 8 Pressure gauge
- 9 Cartridge
- 10 Filter
- 11 Water meter
- 12 Pre-formed shell insulation

Installation

The unit is supplied in three pieces. It must be assembled as follows:

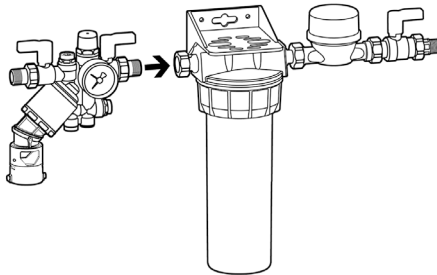

Then, insert the resin inside the cartridge and put on the insulation.

The installation of the unit should only be carried out by qualified personnel in accordance with current regulations.

According to the regulation EN 1717, the backflow preventer is equipped with an inspectable strainer easily accessible for maintenance, and an adjustable drain tundish. The discharge tundish, complying with standard EN 1717, must be turned downwards and connected to the pipe leading to the sewer. Rotation of the tundish can be locked by means of the two self-tapping screws supplied in the package.

The group must be horizontally installed following the direction of flow as indicated by the arrow on the automatic charging unit with backflow preventer.

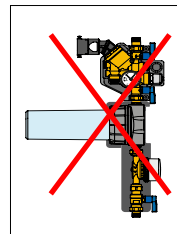
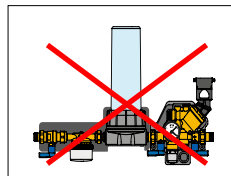
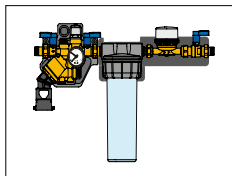

The unit must be installed in an accessible position, appropriately located to avoid immersion due to accidental flooding (see diagram), and not at risk of freezing.

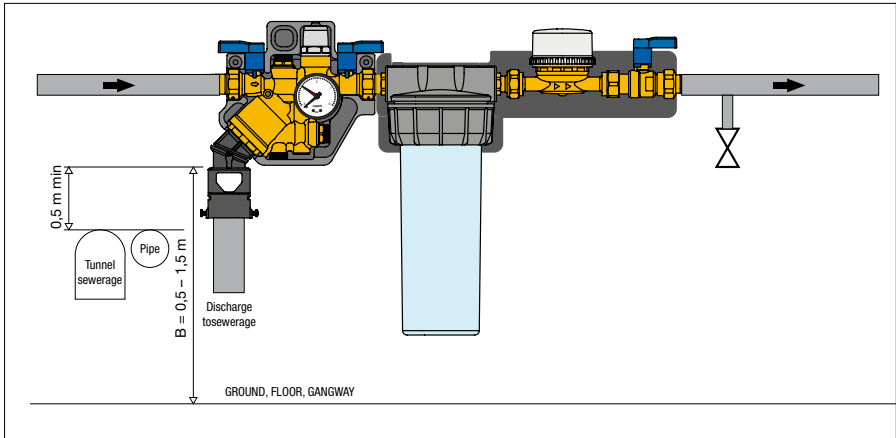

Commissioning

1. Setting the filling unit

- 1) The unit is normally set to a pressure no lower than that obtained by adding to the hydrostatic pressure the value of 0,3 bar.
- 2) The system filling pressure may be set, turning the regulating screw, during the system filling phase.

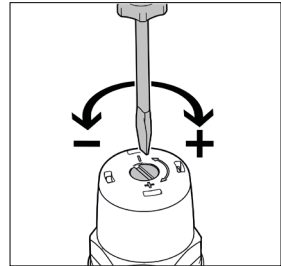

2. Unit filling

Slowly open the shut-off valve upstream of the unit, keeping the downstream shut-off valve closed.

3. Flow meter reading

Reading of the volume meter at the start and end of the filling informs the user about the volume of water in the system and thus allows to check sizing and quantity of cartridges required for the water treatment.

It is recommended to note the system water volume in the maintenance booklet to make this information available for subsequent filling.

4. Air discharge

Slowly open the shut-off valve downstream of the unit and open drain to discharge air contained in the cartridge (13).

Commissioning for refilling

Rinse and system re-filling

Slowly open the downstream shut-off valve and, before proceed with re-filling, discharge 2 volumes of water by a drain (13).

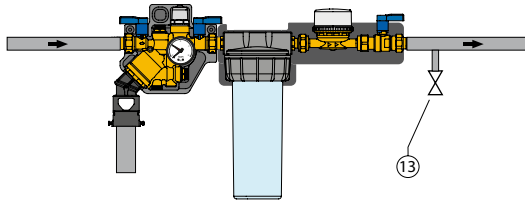

Replacement of demineralization cartridge

The cartridge insert, (code 570925 - 570926) containing the color changing resin beads that demineralized water passing through. It will appear blue color when new. The internal color will change to amber as the resin beads approach a spent condition. The capacity depends on various factors including the temperature of the water, the chemical composition of the water and pressure. For an exact determination it is necessary a water analysis of the raw water.



Cartridge change

1. Close the isolation ball valves. Turn the cartridge with white plastic wrench included with unit.
2. Remove the used cartridge and discard it.
3. Take the new cartridge, remove the red protective cap and insert into the transparent housing, paying close attention to keep the toothed part facing down (code 570925 for unit code 580022 - code 570926 for unit code 580023). The resin is packed to ensure the contents are protected from contamination and loss or uptake of moisture. If packing is damaged or left open and resins are exposed to the atmosphere, the resin can deteriorate through a combination of physical, chemical or biological contamination.
5. Turn the cartridge and tighten in place with the white plastic wrench.
6. Re-open the isolation ball valves to return to normal operation.



Once opened, keep the cartridge wet. Avoid leaving it for a long time in the air: if the resins dry, they lose the ability to treat the water.

White plastic wrench, included in package, required to remove filter housing to replace spent color changing demineralization filter. Please do not dispose and keep in handy location for future use.



**Maintenance
backflow
preventer**

The backflow preventer unit is a health and safety device that requires periodic inspection. According to standard EN 806-5, BA type backflow preventers must be inspected once every six months and subjected to routine maintenance at least once a year. The first indication of poor operation, generally caused by foreign matter (sand or other debris), is revealed with a permanent leakage from the discharge. Such a leakage does not affect safety, but it calls for the device and the upstream strainer housed in the upstream connection on the body to be disassembled and cleaned. The quick checking method is specified in the table shown below. In the event of leakage at the discharge it is recommended to generate a major flow of circulation by opening one or more taps for a few minutes: this is often sufficient to expel any foreign matter and restore normal conditions. A list of visual inspections and functional checks is given in standard EN 806-5. Inspection. Check that the use of water downstream is unchanged and check also compliance with the installation requirements, in accordance with the contents of the "Installation" paragraph.

Maintenance. Clean the upstream strainer and the discharge tundish. Check operation of the components: water-tightness of the check valves and seals, discharge opening/closing tests, measurement of pressure values with suitable instrument (static, dynamic, differential), in accordance with the procedure described below. Log the work performed and functional parameters in the commissioning report. Alert the user in the case of faults and immediately shut off the device upstream until it can be repaired or replaced. It is prohibited to by-pass the backflow preventer, so it is good practice to procure a spare device in the case of critical installations.

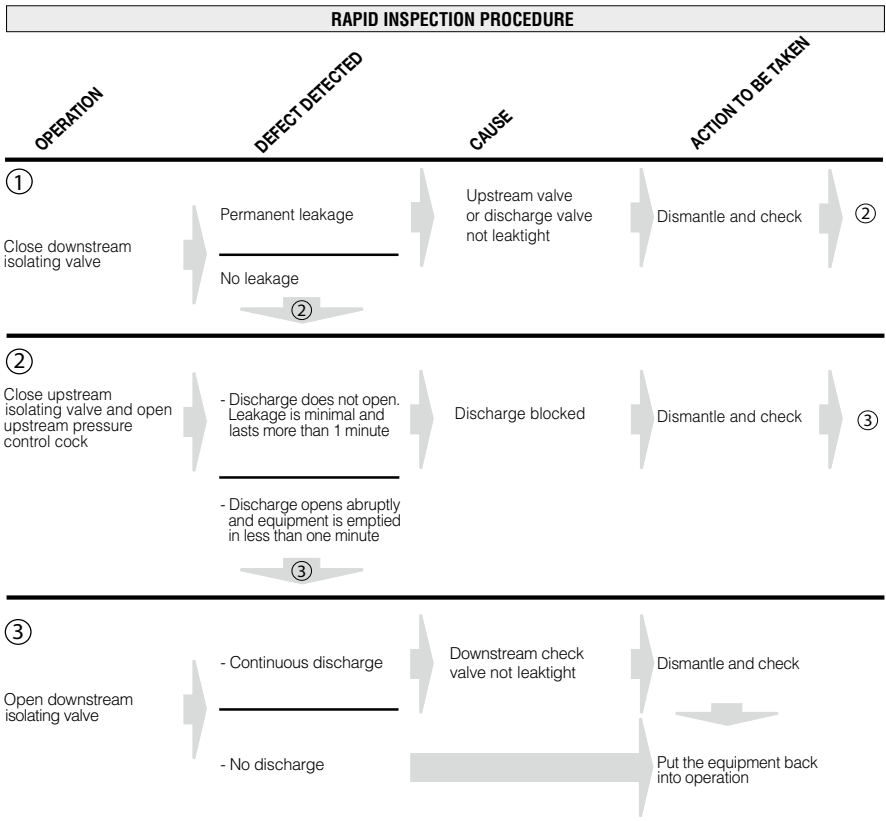

Checks on and where necessary replacements for the internal parts of the backflow preventer

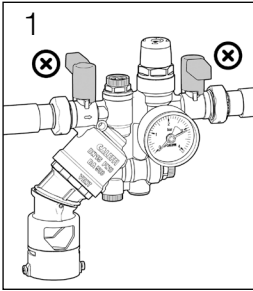

To perform the functional check of the backflow preventer by means of a differential pressure gauge, refer to the instruction sheet 28286. To service internal components, proceed as follows:

1. Close the upstream and downstream shut-off valves. Release the pressure by opening the pressure test ports installed on the backflow preventer.
2. Detach the tundish from the valve body. Undo the cartridge locking nut and withdraw the self-contained cartridge from the valve body. The upstream check valve and the discharge valve are attached to the self-contained cartridge.
3. To service the upstream strainer, remove the cap from the top of the assembly.
4. To service the check valve, undo the locking nut and access the check valve. When the check and/or maintenance is completed, reassemble the components by performing the various steps in reverse order, taking care not to damage the components.

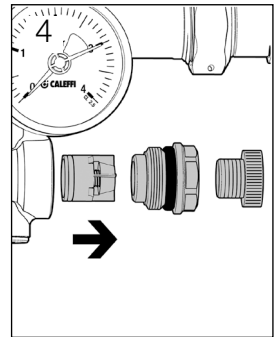
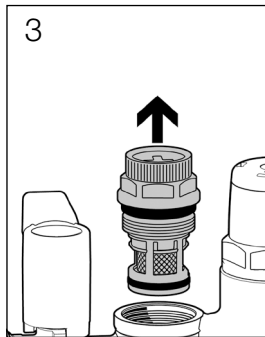
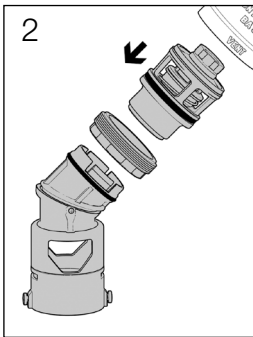

Maintenance pressure reducing valve

The following are necessary for periodic cleaning, inspection and replacement of the entire cartridge:

- 1) Shut off the assembly with the upstream and downstream valves.
- 2)** Loosen the calibration screw all the way.
- 3)** Loosen and remove the cartridge.
- 4) After inspection and any necessary cleaning of the body, the entire assembly can be reassembled or replaced using the spare cartridge.
- 5) Re-calibrate the equipment.

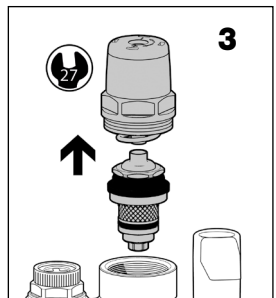
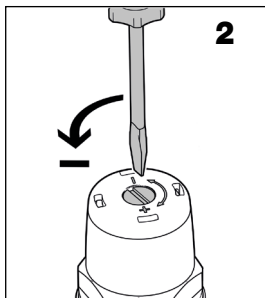

Maintenance downstream filter

The strainer (10) can be removed for maintenance, if the resin container is accidentally broken.

- 1) Close the ball shut-off valves (2)
- 2) Unscrew and remove the volume meter (11)
- 3) Detach the strainer fitting (10), remove the strainer disc inside
- 4) Clean the strainer and reassemble all the components, making sure the unit is sealed.

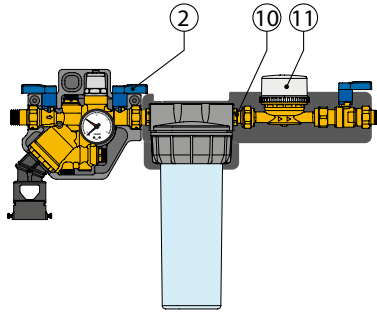

Safety

The filling unit must be installed by qualified personnel in accordance with current regulations.

If the filling unit is not installed, put into operation and serviced correctly in accordance with the instructions given in this manual, then it might not work properly and may cause damage to property and/or persons.

Make sure that all the fittings are watertight.

When making the plumbing connections, take care not to put too much mechanical stress on the unit fittings.

Over time this could cause bursting with hydraulic leakage damaging property and/or persons.

If the water is highly aggressive, there must be provisions to treat it before it enters the filling valve, in accordance with current regulations.

Otherwise, the valve could get damaged and not work properly.

Leave this manual as a reference guide for the user