

**Pressure reducing valve for 1<sup>ST</sup> and 2<sup>ND</sup> stage control**

© Copyright 2023 Caleffi

**5360 AUS series**

**Installation, commissioning and servicing instructions**

**Function**

The 5360 AUS series pressure reducing valve is a high performance valve manufactured specifically for high rise buildings and other applications where high pressures are present and require staged pressure control. The 5360 AUS series carries out the first and second stage pressure reduction in a two valve series where the pressure ratio between the inlet and outlet would be too high for a single pressure reducing valve to control.

The Caleffi 5360 AUS series meet the requirements of “AS1357.2:2005 Valves primarily for use in warm and hot water systems - P. 2: Control valves”.



**Product range**

**5360 AUS**

**1<sup>ST</sup> stage control**

**536043** AUS DN 15 (1/2")

**536053** AUS DN 20 (3/4")

**536063** AUS DN 25 (1")

**536073** AUS DN 32 (1 1/4")

**536083** AUS DN 40 (1 1/2")

Union male end connections (EN 10226-1)



**5360 AUS**

**2<sup>ND</sup> stage control**

**536042** AUS DN 15 (1/2")

**536052** AUS DN 20 (3/4")

**536062** AUS DN 25 (1")

**536072** AUS DN 32 (1 1/4")

**536082** AUS DN 40 (1 1/2")

Union male end connections (EN 10226-1)



**Technical specifications**

**Materials**

Body: dezincification resistant alloy **CR** EN 1982 CC770S  
 Cover: brass EN 12165 CW617N  
 Control spindle: dezincification resistant alloy **CR** EN 12164 CW602N  
 Spring: stainless steel ISO 6931-1 (4310-301-00)  
 Control piston: stainless steel EN 10088-3 (AISI 303)  
 Seals: EPDM  
 Strainer: stainless steel EN 10088-2 (AISI 304)  
 Seat: stainless steel EN 10088-3 (AISI 303)  
 Cartridge: dezincification resistant alloy **CR** EN 12165 CW602N

**Performance**

Max. pressure upstream: 2500 kPa (5360.3)  
 2000 kPa (5360.2)  
 Downstream pressure setting range: 600-1000 kPa (5360.3)  
 100-600 kPa (5360.2)  
 Factory setting: 800 kPa (5360.3)  
 300 kPa (5360.2)  
 Max. working temperature: 80 °C  
 Pressure gauge scale: 0-2500 kPa (5360.3)  
 0-1000 kPa (5360.2)  
 Filter mesh size Ø: (DN 15–DN 25) 0,51 mm  
 (DN 32–DN 40) 0,65 mm  
 Medium: water  
 Flow rate: see graph  
 Complies with: AS 1357.2

## Dimensions

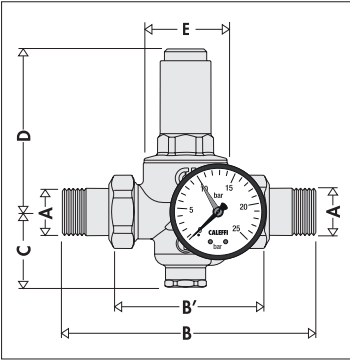

DN	A	B	B'	C	D		E	Weight (kg)
					1 <sup>st</sup> stage	2 <sup>nd</sup> stage		
15	1/2"	140	76	53,5	85,3	89,3	Ø 51	1,5
20	3/4"	160	90	53,5	115,7	111,7	Ø 60	2
25	1"	180	95	53,5	115,7	111,7	Ø 60	2,3
32	1 1/4"	204	110	62,8	135,2	130,2	Ø 72	3,4
40	1 1/2"	220	120	62,8	135,2	130,2	Ø 72	4

## Pressure drop diagram 1<sup>st</sup> stage control

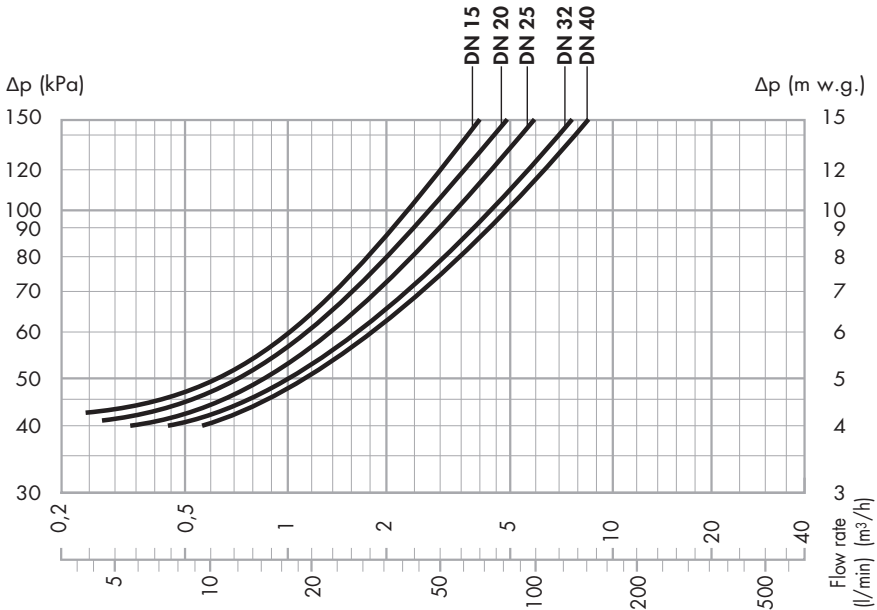

Under following conditions: Inlet pressure 1600 kPa  
Outlet set pressure: 800 kPa

Flow rate (AS 1357.2):

DN 15	DN 20	DN 25	DN 32	DN 40	
40 l/min	60 l/min	70 l/min	90 l/min	120 l/min	@ 600 kPa
60 l/min	75 l/min	80 l/min	110 l/min	125 l/min	@ 800 kPa
120 l/min	140 l/min	200 l/min	220 l/min	240 l/min	@ 1000 kPa

## Pressure drop diagram 2<sup>ND</sup> stage control

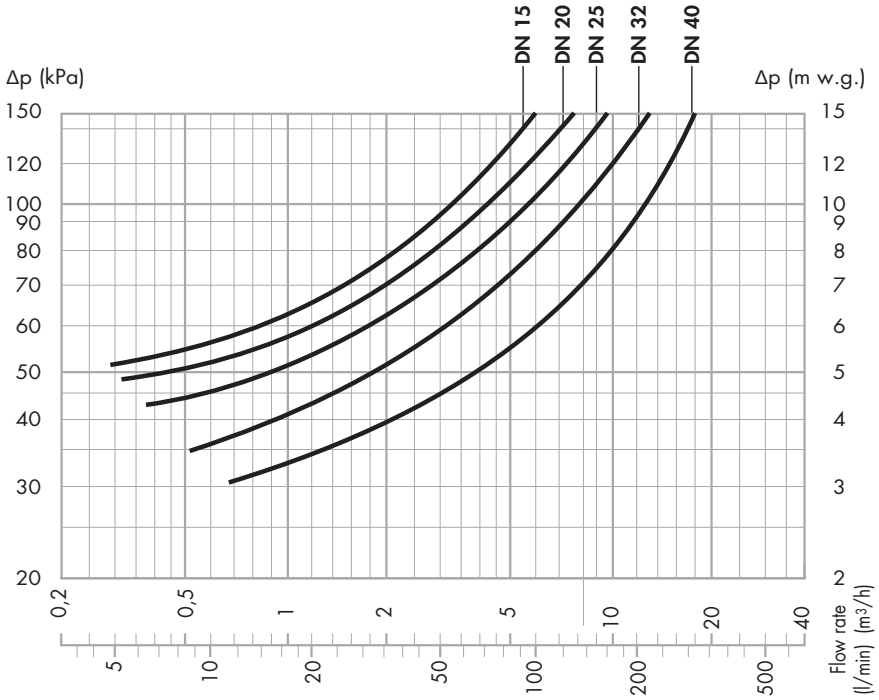

Under following conditions: Inlet pressure 800 kPa  
Outlet set pressure: 300 kPa

Flow rate (AS 1357.2):

DN 15	DN 20	DN 25	DN 32	DN 40	
30 l/min	50 l/min	60 l/min	80 l/min	100 l/min	@ 100 kPa
40 l/min	65 l/min	80 l/min	110 l/min	115 l/min	@ 300 kPa
100 l/min	150 l/min	180 l/min	200 l/min	220 l/min	@ 600 kPa

## Installation

The pressure reducing valve has to be sized in accordance with the system design and the proper selection of the project flow rate, for avoiding any oversizing or undersizing with possible malfunctioning.

The pressure reducing valve must be installed by a licensed plumber and in accordance with AS/NZS 3500, relevant local requirements and following these instructions.

The installer must:

- ensure the reducing valve is compatible with any other equipment in the system it may interact with or come into contact with logistically;
- assess and acknowledge all hazards related to the use of the product, including leaks, by installing the unit properly;
- install shut-off valves fitted with pressure ports or similar equipment to measure the upstream pressure.

## Installation diagram

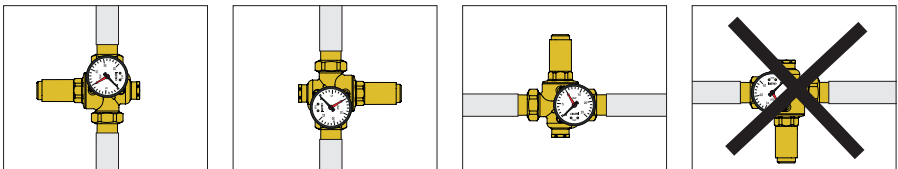
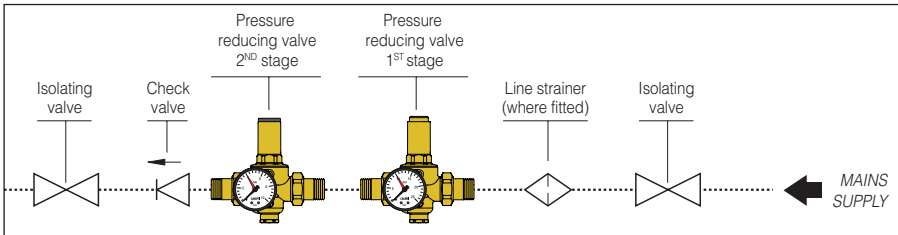

- 1) Before installing the pressure reducer, open all the outlets to flush the system and expel any air or debris in the pipework.
- 2) Install shut-off valves upstream and downstream to facilitate maintenance operations.
- 3) The pressure reducer can be installed in either vertical or horizontal pipework. However it must not be installed upside down.
- 4) Close the downstream shut-off valve.
- 5) Calibrate by means of the spring pressure regulating nut located under the head cover, turning with a 10 mm exagonal Allen key to increase the set value or anticlockwise to reduce it.
- 6) Check the required pressure on the pressure gauge (Caleffi reducers come factory set at 800 or 300 kPa).

# Large system with recirculation

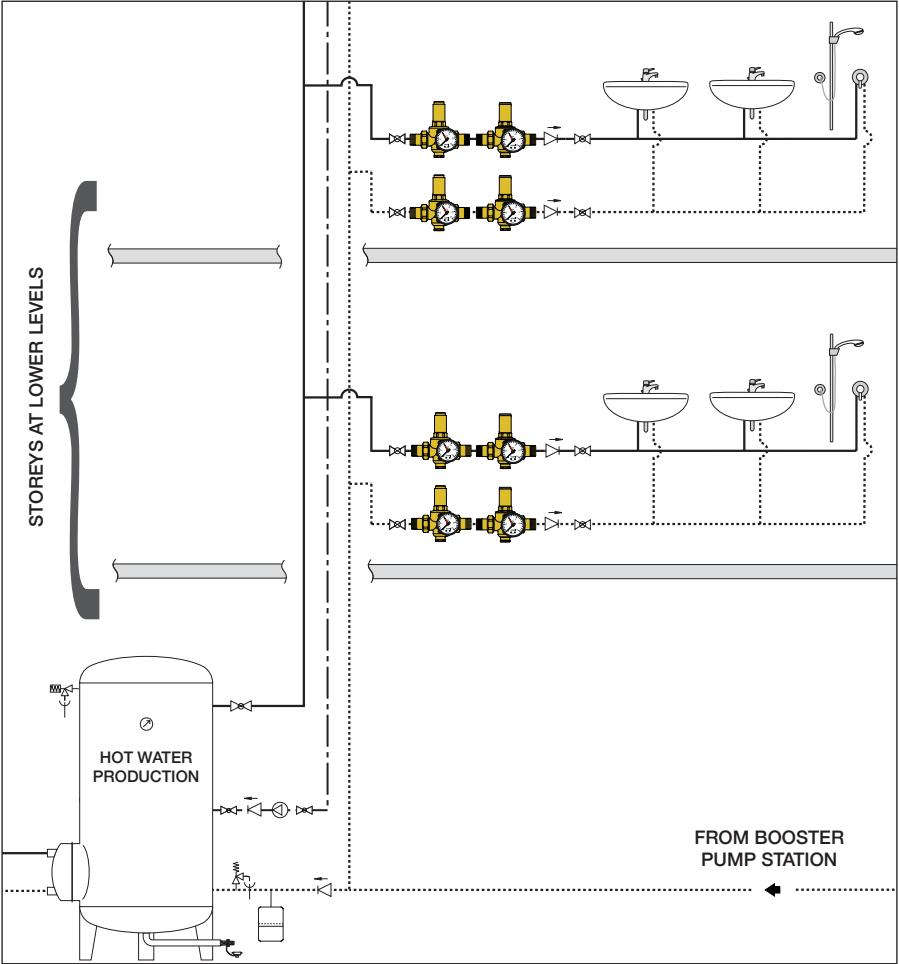

## Recommendation for installation conditions

When installed upstream of a hot water tank, we recommend installing an expansion vessel or similar equipment to absorb the increase in pressure due to the thermal expansion of the water.

When installed in large buildings, adopt technical measures such as using short pipes or including expansion valves and similar equipment to limit the increased pressure due to the thermal expansion of the water caused by temperature changes downstream of the reducing valve itself (or downstream of the first and second stage reducing valves, if two are present).

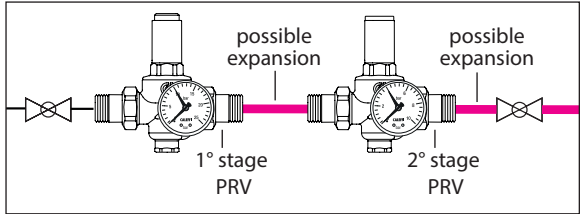
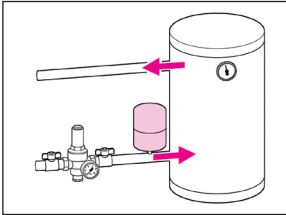

To minimize the risk of cavitation within the valve that may result in malfunctioning with erosion of valve sealing area, vibrations and noise, it is highly recommended to refer to the working conditions represented in the below diagram.

Due to the numerous factors and variable conditions experienced such as system pressure, water temperature, air presence, flow rate and velocity, which may affect the behavior of the pressure reducing valve, it is advisable that the pressure ratio between the upstream pressure and the downstream set pressure is kept ideally to a value 2:1 and no greater than a value 3:1 (For example, upstream 1000 kPa, set pressure 500 kPa, the pressure ratio =  $1000/500 = 2:1$ ). In these conditions, the possible risk of cavitation and malfunctioning is minimised, however this does not exclude the possible effects of the many other variables within the system under operating conditions. If the pressure ratio exceeds the indicated limit, the system design pressure or **use of 1st stage pressure reducing valves** shall be reviewed (For example, 1st stage reducing pressure from 1600 to 800 kPa and then 2nd stage from 800 to 400 kPa).

Cavitation diagram

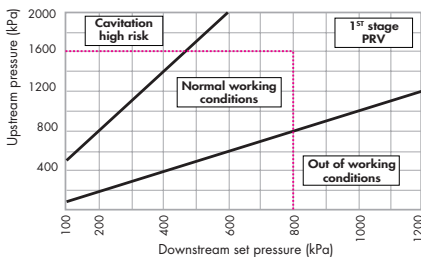

Cavitation diagram

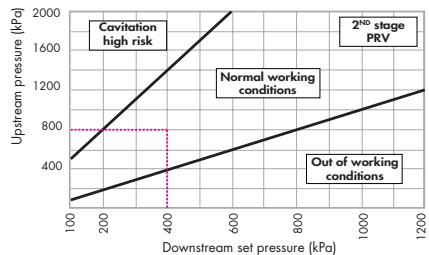

Pipework upstream and downstream of the pressure reducing valve shall be supported in accordance with the manufacturer's instructions, AS/NZS 3500 along with any other local authority requirements, to avoid the creation and transfer of vibration and/or noise into the installation.

The inlet strainer of the pressure reducing valve shall be periodically checked and cleaned, to minimize any partial or complete blockage which may limit the flow rate from the valve and/or create noise.

System flushing, cleaning and disinfection of the pipework to which the valve is installed shall be performed by suitably qualified persons in accordance with the system component manufacturer's instructions, AS/NZS 3500 along with any other applicable local authority requirements. Exceeding the maximum stated chemical concentrations and/or duration of exposure may negatively impact on the performance of the system and/or components installed such as the pressure reducing valve. Chemical dosed products must be chemically compatible with materials used for the construction of the pressure reducing valve, specified in its technical documentation.

### Installation below ground

If installing the 5360 AUS series valve underground, please ensure that steps are taken to protect the valve from becoming frozen in frost-prone areas.

Please allow yourself sufficient space to remove the cartridge should maintenance be required. The reading of a gauge for setting purposes may be difficult and an alternate means of checking downstream pressure may be necessary.

### Water hammering

This is one of the main causes of faults in pressure reducing valves. It is best to fit special devices to absorb water hammering when fitting pressure reducing valves in systems at risk.



#### **WARNING:**

If it is **critical** to maintain the downstream pressure setting to protect equipment, as a safety measure, we recommend that a pressure, or safety, relief valve is installed downstream of the pressure reducing valve.

### Maintenance

The reducing valve must be checked and serviced in compliance with the provisions of applicable regulations. Even when installed, commissioned and serviced properly, the reducing valve's internal components are subject to normal wear and tear, which may result in leaks and other malfunctions. We advise that you check that it is in good working order and service and clean the cartridge at least every 12 months.

For cleaning, inspection or replacement of the entire cartridge:

- 1) Isolate the reducer.
- 2) Unscrew the spring pressure regulating nut to release the spring tension.
- 3) Remove the head cover.
- 4) Extract the cartridge using two screwdrivers.
- 5) After inspection and cleaning if necessary, the complete cartridge can be refitted or replaced using a spare cartridge.
- 6) Recalibrate the reducer.

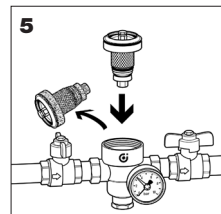
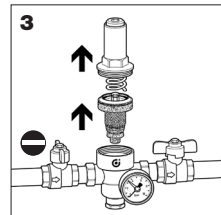

## Trouble-shooting

### 1. Increased downstream pressure near a water heater

This problem is due to the water being heated by the water heater. There is no relief of the pressure because the reducing valve is correctly closed. The solution is to install an expansion vessel (between the heater and the reducer) to "absorb" the pressure increase or **an expansion control valve** to relief the pressure.

### 2. The pressure reducing valve does not maintain its set pressure

In most cases this is the result of impurities that deposit on the valve seat causing leakage with a resulting increase in pressure downstream. The solution is to fit a filter upstream from the reducer and subsequently to maintain and clean the cartridge (see *Maintenance*).



#### **Safety**

If the pressure reducing valve is not installed, commissioned and maintained properly in accordance with the instructions contained in this manual, it may not operate correctly, and may cause damage to objects and/or persons.

Make sure that all the connections are water-tight.

When installing the pressure reducing valve, make sure not to over-tighten the connections to the valve, as, over time, a failure can occur with subsequent water leakage causing damage.

In the case of highly aggressive water, arrangements must be made to treat the water before it enters the pressure reducing valve, in accordance with current legislation. Otherwise, the pressure reducing valve may be damaged and not function correctly.

**Leave this manual as a reference guide for the users**

**AUSTRALIAN AGENT**

**All Valve Industries**

**Unit 2, 18-28 Sir Joseph Banks Drive  
Kurnell NSW 2231**

**Ph: (02) 8543 9811**

**Fax: (02) 8543 9822**

**Email: [info@allvalve.com.au](mailto:info@allvalve.com.au)**

**CALEFFI**