



Deaerator DISCAL®

551 series

www.caleffi.com



- Allows the separation of air contained in the hydraulic circuits of heating and cooling system.
- Automatic air removal from the system down to micro-bubble level, with very low pressure drop.
- From DN 50 to DN 150 flanged DISCAL® deaerators are supplied complete with hot pre-formed shell insulation.
- Adjustable for horizontal and vertical pipes (only for 5517 series).
- Reduced wear and tear of boilers, heat exchangers, pipes.
- Equipped with a high-performance automatic air vent.



PRODUCT RANGE - DISCAL®

THREADED CONNECTIONS



CODE	CONNECTION
551005	3/4"
551006	1"
551007	1 1/4"
551008	1 1/2"
551009	2"

FLANGED CONNECTIONS



CODE	CONNECTION
551052	DN 50
551062	DN 65
551082	DN 80
551102	DN 100
551122	DN 125
551152	DN 150
551200*	DN 200
551250*	DN 250
551300*	DN 300

*without insulation

CONNECTIONS FOR VERTICAL PIPES



CODE	CONNECTION
551705	3/4" F
551706	1" F
551716	1" M
551702	Ø 22
551703	Ø 28

PERFORMANCE

WORKING TEMP. THREADED	0–110°C
WORKING TEMP. DN 50–DN 100	0–105°C
WORKING TEMP. DN 125–DN 150	0–100°C
WORKING TEMP. DN 200–DN 300	0–110°C
PRESSURE	10 bar
MAX. GLYCOL	50 %

OPERATING PRINCIPLES

The deaerator uses the combined action of several physical principles. The active part consists of an assembly of concentric metal mesh surfaces. These elements create the whirling movement required to facilitate the release of micro-bubbles and their adhesion to these surfaces. The bubbles, fusing with each other, increase in volume until the hydrostatic thrust is such as to overcome the adhesion force to the structure. They rise towards the top of the unit from which they are released through a float-operated automatic air release valve. It is designed in such a way that the direction in which the medium is flowing inside it makes no difference.

3D CROSS SECTION

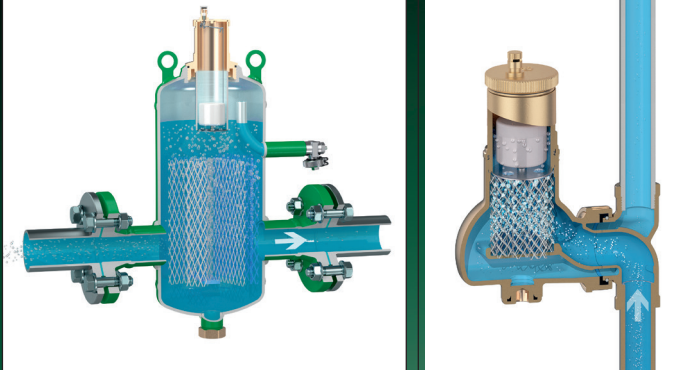

APPLICATION DIAGRAM

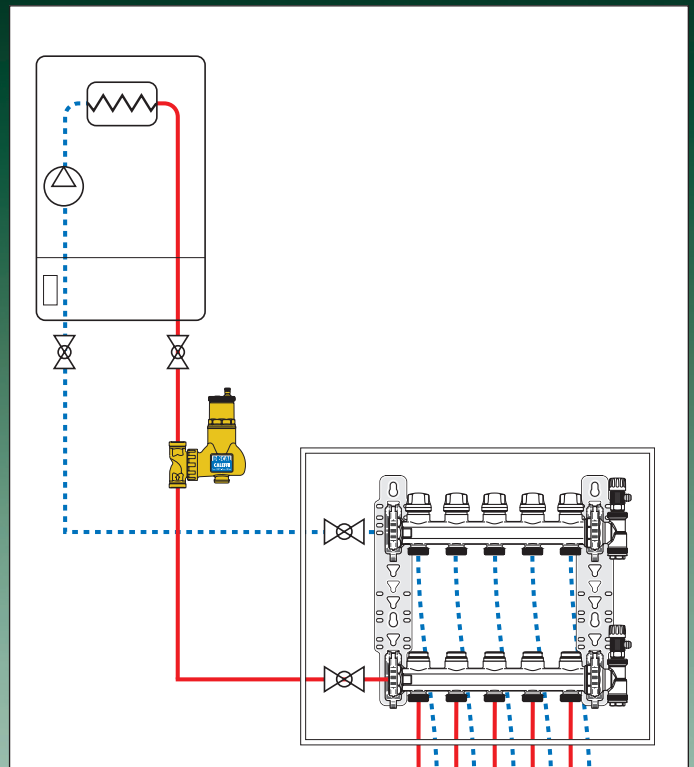

INSULATION

Threaded models codes 551005-6-7-8-9 can be equipped with hot pre-formed shell insulation as optional. This system ensures not only perfect thermal insulation, but also the tightness required to prevent atmospheric water vapour from entering the unit. For this reason, this type of insulation may also be used in cooling water circuits as it prevents condensation from forming on the surface of the valve body.



REFERENCE DOCUMENTS:

551 series - Technical brochure 01060

CALEFFI
Hydronic Solutions

WE RESERVE THE RIGHT TO MAKE CHANGES AND IMPROVEMENTS TO THE PRODUCTS AND RELATED DATA IN THIS PUBLICATION, AT ANY TIME AND WITHOUT PRIOR NOTICE.

Caleffi S.p.A. S.R. 229 n. 25 · 28010 Fontaneto d'Agogna (NO) · Italy
Tel. +39 0322 8491 · Fax +39 0322 863723
info@caleffi.com · www.caleffi.com · © Copyright 2024 Caleffi