

Hydro separator



NA548 series, ASME/CRN, 5" - 6" with flanges

Submittal Data 2910.2 NA — Issue Date 10/2018

Application

The hydraulic separator creates a zone with a low pressure loss, which enables connected primary and secondary circuits to be hydraulically independent of each other; the flow in one circuit does not create or interrupt flow in another. Hydraulically decoupling primary and secondary circuits eliminates pump conflict.

Typical Specification

Furnish and install on the plans and described herein, a Caleffi Hydro Separator as manufactured by Caleffi. Each separator must be designed with an epoxy resin painted steel body, 304 stainless steel internal baffle, preformed insulation, a brass blowdown drain valve and automatic brass air vent isolated manually with brass shutoff valve. The separator design must include ANSI B16.5 Class 150 RF flanges. The separator is designed and built in accordance with Section VIII, Division 1 of the ASME Boiler and Pressure Vessel Code and tagged and registered with the National Board of Boiler and Pressure Vessel Inspector, and CRN registered, and stamped for 150 psi (10 bar) working pressure, with ASME U stamp. Each separator shall be a Caleffi model NA548 series or approved equal. (See product instructions for specific installation information.)

Technical data

- Materials**
- separator body: epoxy resin painted steel
 - air vent body: brass
 - shut off and drain valve body: brass
 - internal baffle: 304 stainless steel

Performance

- Suitable fluids: water and non-hazardous glycol solution up to 50%
 Max. operating pressure: 150 psi (10 bar)
 Working temperature range with insulation: 32–220°F (0–105°C)
 Working temperature range without insulation (vessel): 32–270°F (0–132°C)

- Connections**
- main: 5"-6" ANSI B16.5 150 CLASS RF
 - drain valve: 1¼" NPT female

Dimensions

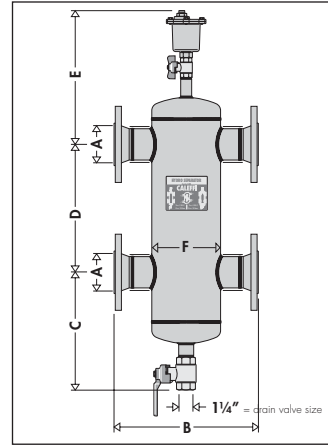

Code	A	B	C	D	E	F	Wt. (lbs.)	Wt. (kg)
NA548120A	5"	25"	15"	22"	17½"	12¾"	220	100
NA548150A	6"	25"	15"	22"	17½"	12¾"	231	105

ASME tagged and registered with the National Board of Boiler and Pressure Vessel Inspectors and CRN registered, with ASME U stamp.

Hydraulic characteristics

The hydraulic separator should be sized according to the maximum flow rate value at the inlet. The selected design value must be the greatest required flow rate of either the primary circuit or the secondary circuit.

Flanged connections

Size	5"	6"
gpm	300	484
l/s	19	30
gallons	23	23
liters	87.0	87.0

We reserve the right to change our products and their relevant technical data, contained in this publication, at any time and without prior notice. Contractors should request production drawings if prefabricating the system.

Job name _____
 Job location _____
 Engineer _____
 Mechanical contractor _____
 Contractor's P.O. No. _____
 Representative _____

Size _____
 Quantity _____
 Approval _____
 Service _____
 Tag No. _____
 Notes _____