

MixCal™ Adjustable three-way thermostatic mixing valve, NPT



Submittal Data 02902 NA — Issue Date 11/2021

Application

The Caleffi MixCal™ 521 series three-way thermostatic mixing valve is used in systems producing domestic hot water or in hydronic and radiant heating systems. It maintains the desired output temperature of the mixed water supplied at a constant set value compensating for both temperature and pressure fluctuations of the incoming hot and cold water. The MixCal thermostatic mixing valve is ICC-ES certified to ASSE 1017 and CSA B125.3. It complies with codes IPC, IRC, accordance with the US and Canadian plumbing codes, and standard NSF/ANSI 372, low lead. Low-lead ball valves available for inlet and outlet isolation, field install.



Typical Specification

Furnish and install on the plans described herein, a MixCal three-way thermostatic mixing valve as manufactured by Caleffi. Each mixing valve must be designed with a low-lead brass body, a replaceable brass cartridge chemical nickel plated, stainless steel springs, seals in peroxide-cured EPDM, and shutter, regulating seats and sliding surfaces in anti-scale plastic, PPO. Each valve must also be designed for $\pm 3^{\circ}\text{F}$ ($\pm 2^{\circ}\text{C}$) temperature stability with a tamper proof control knob to lock the temperature at the set value. The valve shall be ASSE 1017 approved for point of distribution installation. Low-lead brass body (<0.25% Lead content) certified by ICC-ES, file 1360. Complies with requirements of NSF/ANSI 372-2016. Provide with optional mixed outlet dual-scale temperature gauge, 30 - 210°F and 0 - 100°C scale, 2 inch diameter. Provide with optional inlet and outlet isolation ball valves, code 290030, separately sourced, field installed. Each valve shall be Caleffi model 521 or approved equal. (See product instructions for specific installation information.)

Technical Data

Materials

Body: low-lead brass
 Shutter, seats and slide guides: PPO
 Springs: stainless steel
 Seals: peroxide-cured EPDM

Performance

Suitable Fluids: water, glycol solution
 Max. percentage of glycol: 30%
 Setting range: 85–150°F (30–65°C)
 Tolerance: $\pm 3^{\circ}\text{F}$ ($\pm 2^{\circ}\text{C}$)
 Max. working pressure: 200 psi (14 bar)
 Max. operating differential pressure: 75 psi (5 bar)
 Max recommended differential pressure: 20 psi (1.5 bar)
 Max. hot water inlet temperature: 200°F (93°C)
 Max. inlet pressure ratio (H/C or C/H) for optimum performance: 2:1
 Min. temperature differential between hot water inlet and mixed water outlet for optimal performance: 27°F (15°C)
 Min. flow to ensure optimal performance: 1.3 gpm (5 L/min)
 Minimum flow rate when recirculation flow rate is 1 gpm or greater: 0 gpm (0 L/min)
 Outlet temperature gauge (optional): 2" diameter
 Dual-scale 30°F - 210°F and 0°C - 100°C

Dimensions

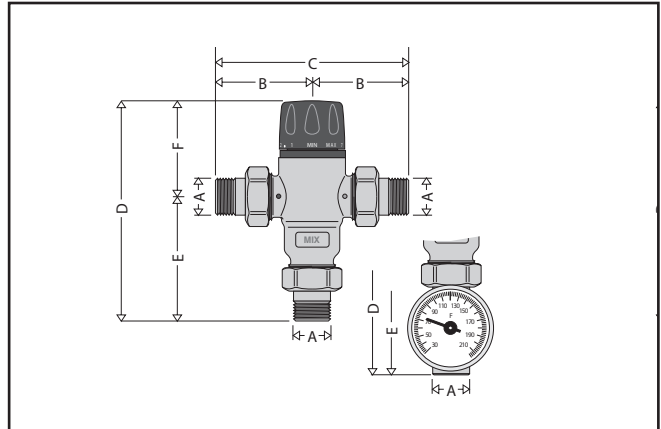

Code	A	B	C	D*	E	F	Wt. (lb.)
NPT Threaded connections							
521400A	1/2"	2 5/8"	5 1/4"	6"	3 3/8"	2 5/8"	2.4
521400AC	1/2"	2 5/8"	5 1/4"	6"	3 3/8"	2 5/8"	2.4
521410A**	1/2"	2 5/8"	5 1/4"	7 3/8"	4 3/4"	2 5/8"	2.9
521410AC**	1/2"	2 5/8"	5 1/4"	7 3/8"	4 3/4"	2 5/8"	2.9
521500A	3/4"	2 5/8"	5 1/4"	6"	3 3/8"	2 5/8"	2.4
521500AC	3/4"	3"	6"	6"	3 3/8"	2 5/8"	2.4
521510A**	3/4"	2 5/8"	5 1/4"	8"	5 3/8"	2 5/8"	2.9
521510AC**	3/4"	3"	6"	8"	5 3/8"	2 5/8"	2.9
521600A	1"	2 7/8"	5 3/4"	6 1/4"	3 3/4"	2 5/8"	2.4
521600AC	1"	3 1/16"	6 1/8"	6 1/4"	3 3/4"	2 5/8"	2.4
521610A**	1"	2 7/8"	5 3/4"	7 5/8"	5 1/8"	2 5/8"	2.9
521610AC**	1"	3 1/16"	6 1/8"	7 5/8"	5 1/8"	2 5/8"	2.9

C at the end of the code are models with integral inlet port check valves.

*At minimum temperature position on adjusting knob.

**Model with integral outlet temperature gauge.

Certifications:

- ASSE 1017/CSA B125.3, certified by ICC-ES, file PMG-1357.
- Complies with NSF/ANSI 372, Drinking Water System Components-Lead Content Reduction of Lead in Drinking Water Act, California Health and Safety Code 116875 S.3874, Reduction of Lead in Drinking Water Act, as certified by ICC-ES, file PMG-1360.

Connections:

NPT male union

1/2", 3/4", 1"

We reserve the right to change our products and their relevant technical data, contained in this publication, at any time and without prior notice. Contractors should request production drawings if prefabricating the system

Job name _____
 Job location _____
 Engineer _____
 Mechanical contractor _____
 Contractor's P.O. No. _____
 Representative _____

Size _____
 Quantity _____
 Approval _____
 Service _____
 Tag No. _____
 Notes _____