

# Connection and regulation kit for HVAC terminal units

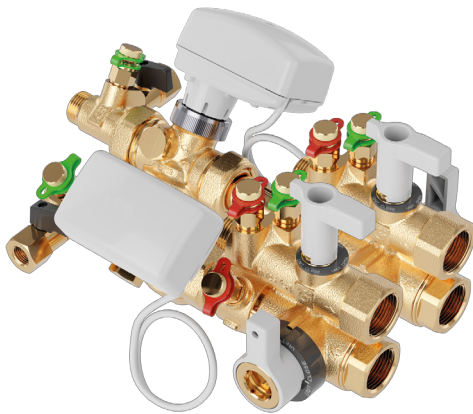

01349 20 EN

## 149 series



### Functions

The pre-assembled kit for terminal units is compact and able to shut-off, adjust and filter the secondary circuit of the terminal unit. It also allows to perform maintenance and setting operations of the system. It allows the connection of fan-coils, cold beams or ceiling-mounted air-conditioning systems with the main distribution system. Complete with Venturi device for flow rate measurement.

### Product range

149 series Connection and regulation kit for HVAC terminal units

### Reference documentation

- Tech. broch. 01262 FLOWMATIC® pressure independent control valve (PICV). 145 series.

### Technical specifications

#### Materials

Body:	dezincification resistant alloy <b>CR</b> EN 12165 CW602N
Strainer mesh:	AISI 304
Shut-off valve knobs:	PA6G30

#### PICV

Body and headwork:	dezincification resistant alloy <b>CR</b> EN 12164 CW602N
Control stem and piston:	stainless steel EN 10088-3 (AISI 303)

Obturator seat:	- (H08, H20): dezincification resistant alloy EN 12164 CW602N
	- (H40, H80 and 1H2): PTFE

Obturator:	EPDM
Pressure regulator diaphragm:	EPDM
Springs:	stainless steel EN 10270-3 (AISI 302)
Seals:	EPDM
Seals:	non-asbestos fibre
Preset indicator:	PA6G30
Knob:	PA6

#### Connections

System side:	3/4"
Terminal unit side:	3/4" Ø 18

#### Performance

Medium:	water, glycol solutions
Maximum percentage of glycol:	50 %
Max. working pressure:	25 bar
Max. differential pressure with actuator code 145013 and 6565 series thermo-electric actuators:	4 bar
Working temperature range:	-10–120 °C
Ambient temperature range:	0–50 °C
Nominal Δp operating range:	25–400 kPa
Flow rate regulation range:	0,02 – 1,2 m³/h
Strainer mesh size:	800 μm

#### Actuator code 145013

Proportional linear actuator	
Electric supply:	24 V (AC)/(DC)
Power consumption:	2,5 VA (AC) • 1,5 W (DC)
Control signal:	0(2)–10 V, 0(4)–20 mA
Feedback signal:	0–10 V
Protection class:	IP 54
Ambient temperature range:	0–50 °C
Supply cable length:	2 m
Connections:	M30 p.1,5
Opening and closing time:	35 s (with automatic stroke detection)

#### Actuator code 656524

Normally closed	
Electric supply:	24 V (AC)/(DC)
Power consumption:	1,2 W
Control signal:	0–10 V
Feedback signal:	0–10 V
Protection class:	IP 54
Ambient temperature range:	0–60 °C
Supply cable length:	1 m
Connections:	M30 p.1,5
Starting current:	320 mA
Opening and closing time:	200 s

#### 6565 series thermo-electric actuator

Normally closed	
Electric supply:	230 V (code 656502) 24 V (AC/DC) (code 656504)
Power consumption:	1 W
Control signal:	ON/OFF
Protection class:	IP 54
Ambient temperature range:	0–60 °C
Supply cable length:	1 m
Connections:	M30 p.1,5
Starting current:	550 mA (code 656502) 300 mA (code 656504)
Opening and closing time:	240 s

**Codes**

Single installation code 149500 ... 001

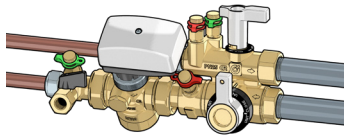

Code 145500 ... 001

Code	DN	Main connections	Connections to terminal unit	Flow rate range	Kv Venturi (m³/h)
149500 H08 001	20	3/4" F	3/4" Euroconus	0,02–0,08m³/h	0,15
149500 H20 001	20	3/4" F	3/4" Euroconus	0,08–0,20m³/h	0,50
149500 H40 001	20	3/4" F	3/4" Euroconus	0,20–0,40m³/h	1,10
149500 H80 001	20	3/4" F	3/4" Euroconus	0,40–0,80m³/h	2,25
149500 1H2 001	20	3/4" F	3/4" Euroconus	0,60–1,20m³/h	3,90

Double installation code 149500 ... 001 + code 149500 ... 002

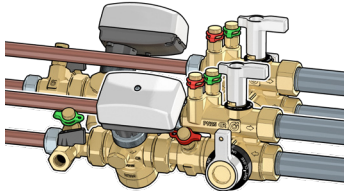

Code 145500 ... 002

Code	DN	Main connections	Connections to terminal unit	Flow rate range	Kv Venturi (m³/h)
149500 H08 002	20	3/4" F	3/4" Euroconus	0,02–0,08m³/h	0,15
149500 H20 002	20	3/4" F	3/4" Euroconus	0,08–0,20m³/h	0,50
149500 H40 002	20	3/4" F	3/4" Euroconus	0,20–0,40m³/h	1,10
149500 H80 002	20	3/4" F	3/4" Euroconus	0,40–0,80m³/h	2,25
149500 1H2 002	20	3/4" F	3/4" Euroconus	0,60–1,20m³/h	3,90

**Dimensions**

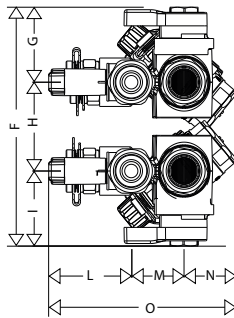
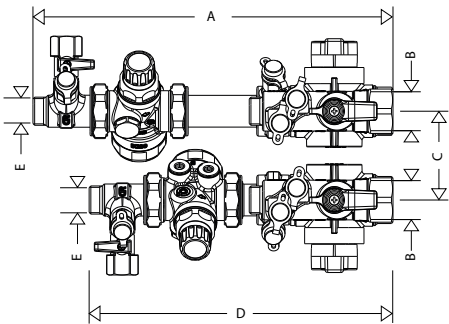

A	B	C	D
276	3/4"	66	233

E	F	G
3/4" Euroconus Ø18	178	56

H	I	L	M
66	56	63	40

N	O
40	143

**Characteristic components**

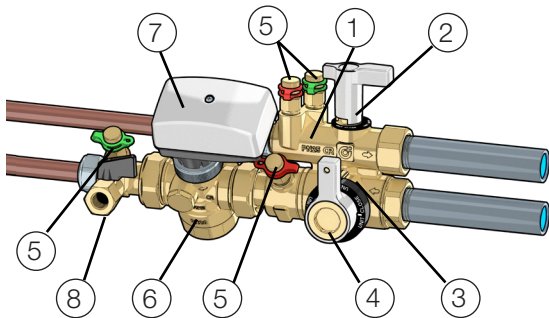

1. Venturi device for flow rate measurement with connections for pressure test ports
2. Three-way shut-off valve
3. By-pass
4. Three-way shut-off valve with built-in strainer
5. Pressure test ports
6. Pressure independent control valve (PICV)
7. Actuator (optional)
8. Filler/drain cock

**Flow rate range shortcut charts**

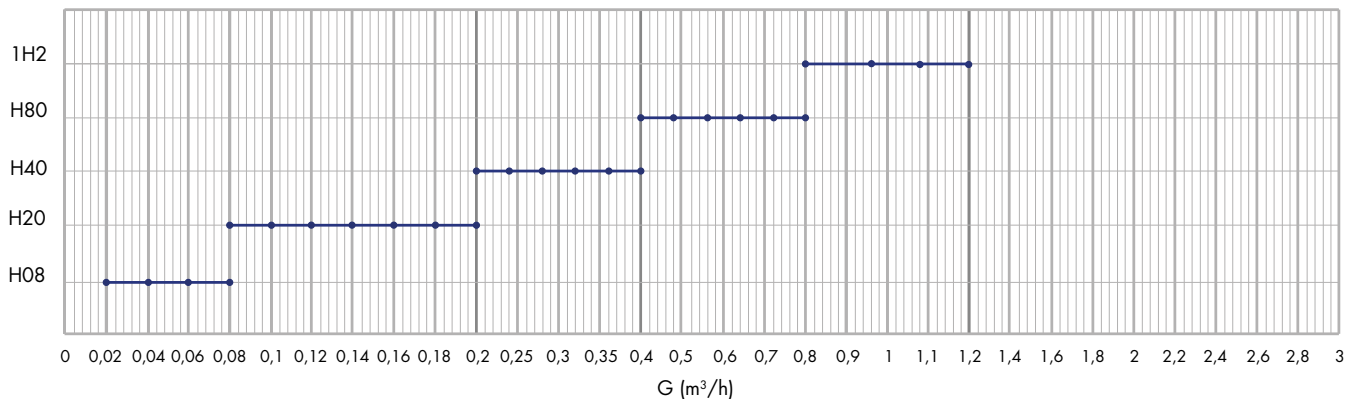

## Hydraulic characteristics

Code Flow rate range	DN	Kv Venturi (m³/h)	Adjustment position										
			1	2	3	4	5	6	7	8	9	10	
H08 0,02–0,08m³/h	20	0,15	Flow rate (m³/h)	0,02	0,04	0,06	0,08	-	-	-	-	-	-
			Δp min PICV (kPa)	25	25	25	25	-	-	-	-	-	-
			Δp by-pass kit (kPa)	2,0	8,2	18,4	32,7	-	-	-	-	-	-
H20 0,08–0,20m³/h	20	0,50	Flow rate (m³/h)	-	-	-	0,08	0,1	0,12	0,14	0,16	0,18	0,2
			Δp min PICV (kPa)	-	-	-	25	25	25	25,5	25,5	26	26
			Δp by-pass kit (kPa)	-	-	-	2,4	3,7	5,3	7,2	9,5	12	14,8
H40 0,20–0,40m³/h	20	1,10	Flow rate (m³/h)	-	-	-	-	0,2	0,24	0,28	0,32	0,36	0,40
			Δp min PICV (kPa)	-	-	-	-	26	26,5	26,5	27	27	27
			Δp by-pass kit (kPa)	-	-	-	-	3,3	4,8	6,5	8,5	10,7	13,2
H80 0,40–0,80m³/h	20	2,25	Flow rate (m³/h)	-	-	-	-	0,4	0,48	0,56	0,64	0,72	0,8
			Δp min PICV (kPa)	-	-	-	-	26	27	27,5	28	28,5	29
			Δp by-pass kit (kPa)	-	-	-	-	3,2	4,6	6,2	8,1	10,2	12,6
1H2 0,60–1,20m³/h	20	3,90	Flow rate (m³/h)	-	-	-	-	0,64	0,72	0,84	0,96	1,08	1,2
			Δp min PICV (kPa)	-	-	-	-	26	26,5	26,5	27	27,5	28
			Δp by-pass kit (kPa)	-	-	-	-	2,7	3,4	4,6	6,1	7,7	9,5

## By-pass kit

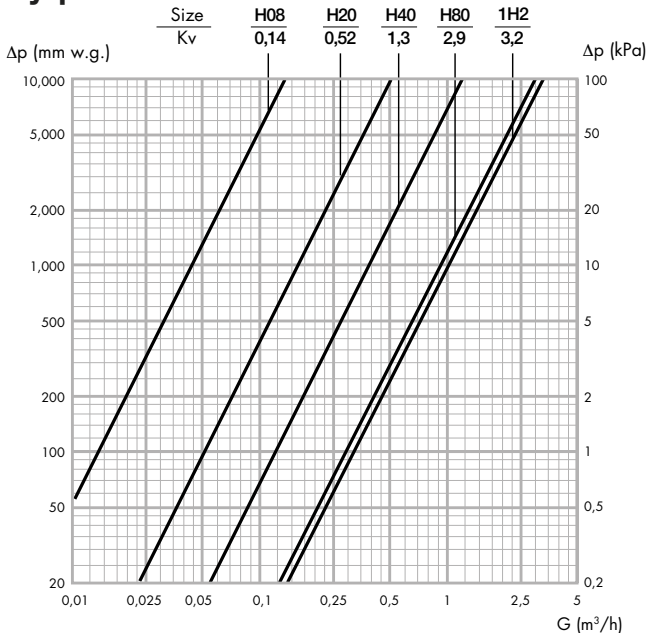

	H08	H20	H40	H80	1H2
Kv kit by-pass (m³/h)	0,14	0,52	1,3	2,9	3,2

## Venturi

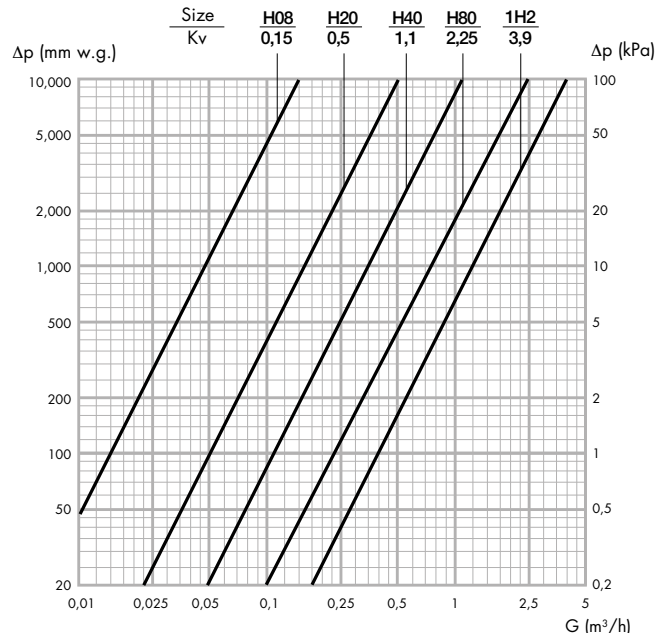

	H08	H20	H40	H80	1H2
Kv Venturi (m³/h)	0,15	0,5	1,1	2,25	3,9

### Minimum differential pressure required

To choose the pump you need to add the minimum pressure difference required by the kit to the fixed pressure drops of the most disadvantaged circuit.

The minimum ΔP of the connection and regulation kit is obtained:

$$\Delta P_{\text{min unit}} = \Delta P_{\text{by-pass kit}} + \Delta P_{\text{min PICV}}$$

where:

$\Delta P_{\text{by-pass kit}}$  = by-pass kit pressure drop

$\Delta P_{\text{min PICV}}$  = minimum PICV pressure drop

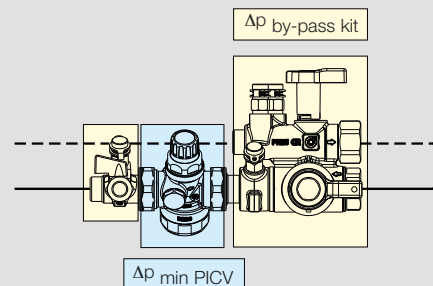

## Operating principle

The kit layout is shown in the diagram below:

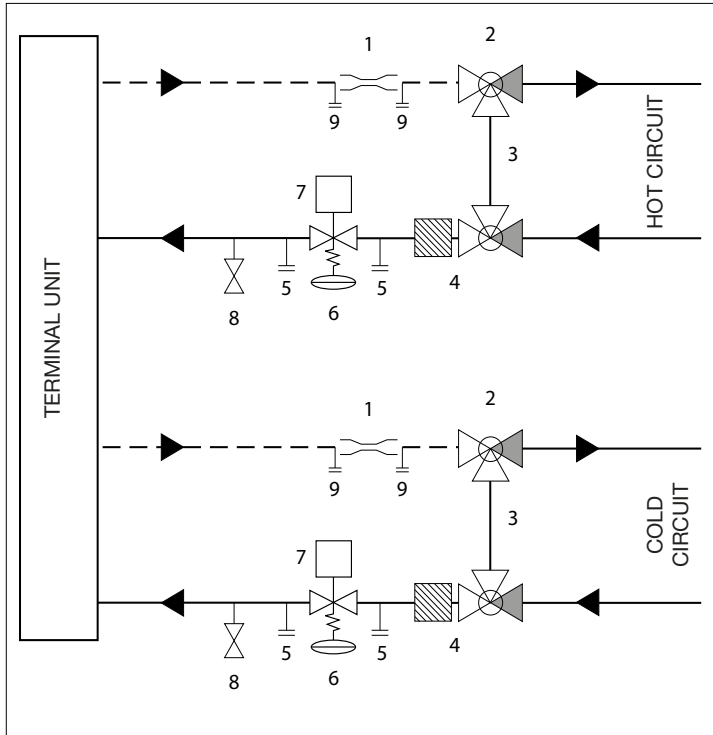

1. Venturi device for flow rate measurement with connections for pressure test ports
2. Three-way shut-off valve
3. By-pass
4. Shut-off valve with built-in strainer
5. PICV pressure test ports
6. Pressure independent control valve (PICV)
7. Actuator (optional)
8. Filler/drain cock
9. Venturi pressure test ports

The kit allows to:

- regulate and maintain the flow rate of the terminal unit constant as the differential pressure conditions of the main circuit change by means of the pressure independent control valve PICV (6);
- isolate the terminal unit through the three-way shut-off valves (2-4);
- divert the flow through the three-way shut-off valves (2-4) and the integrated by-pass (3);
- filter the inlet water to the terminal unit through the strainer located inside the shut-off valve (4);
- measure the flow rate passing through the terminal unit using the Venturi effect device with the pressure test ports (9), which make it easy to connect the measuring instrument;
- clean the circuit and drain the water through the drain cock (8).

## Construction details

### Three-way ball valve

The shut-off valves have been designed with three ways to minimize the dimensions and connections of the kit. The internal ball is designed to open the straight path (A) (for normal operation), the by-pass path (B) (for passage through the by-pass) or to completely close the passage and isolate the circuit of the terminal unit (C).

A - UNIT OPEN

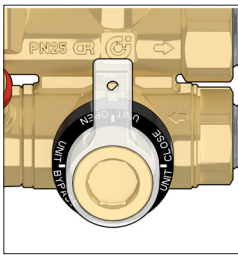

A - UNIT OPEN

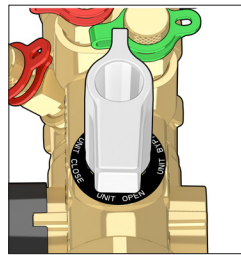

B - UNIT BY-PASS

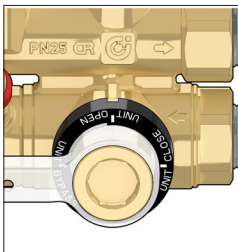

B - UNIT BY-PASS

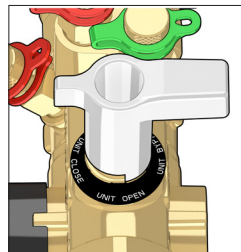

C - UNIT CLOSE

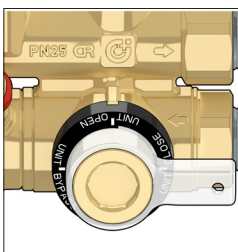

C - UNIT CLOSE

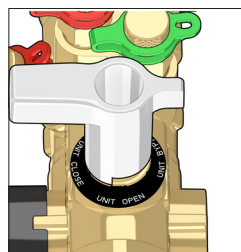

### Integrated by-pass

The kit is equipped with a by-pass, which is an indispensable element for each terminal circuit. The by-pass allows to:

- perform the flushing, washing and cleaning operations of the main circuit pipes without the medium passing through the terminal unit;
- shut off and carry out maintenance operations on the terminal unit.

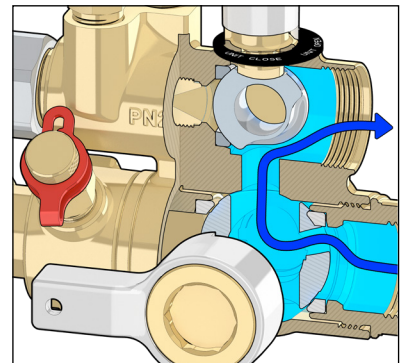

### Built-in strainer

The components of a heating and air conditioning system are exposed to degradation caused by the impurities contained in the system circuit. If impurities in the thermal medium are not removed, they can impair operation of the units or components, such as boilers, heat exchangers, or terminal appliances in the circuits, especially during system commissioning.

The cartridge strainer in the kit mechanically blocks the impurities in the thermal medium (before they reach the terminal unit) and captures them by mechanical selection through a specific wire filter mesh.

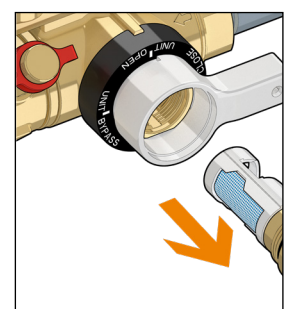
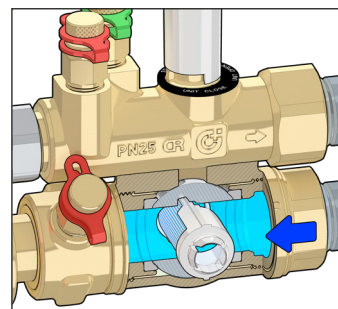

**integrated PICV**

The kit is equipped with a pressure independent control valve (PICV) capable of regulating the flow rate and keeping it constant even when the differential pressure conditions of the system change.

The flow rate is adjusted:

- **manually** on the automatic flow rate regulator, to restrict the maximum value. The adjustment is made turning the locking nut and positioning it on the relative adjustment number: this opens/closes the cross section (A)
- **automatically** by the flow rate control valve in combination with a proportional (0–10 V) or ON/OFF actuator, in accordance with the thermal load requirements of the cross section of the circuit to be controlled. The actuator adjusts the flow rate from the maximum value to the minimum value by acting on the vertical displacement of the control stem (B).

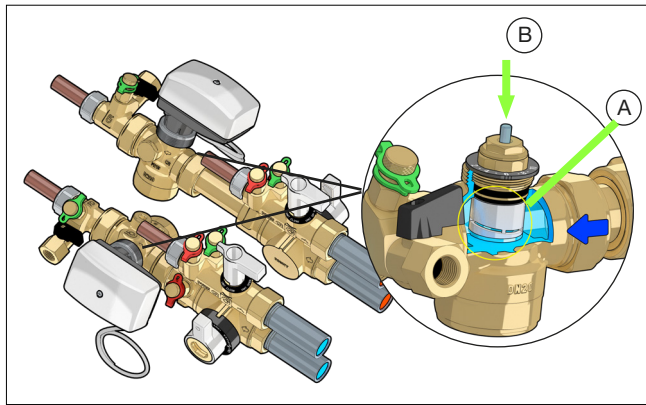

**Flow rate meter**

The kit contains a flow rate metering device based on the Venturi effect. The possibility of measuring the flow rate in a simple way facilitates system setting and commissioning operations. The metering device contains a diaphragm that, by restricting the cross-section of the channel, speeds up the medium and generates increased  $\Delta p$  (as measured) at the ends in order to guarantee precise flow rate measurement.

Each differential pressure value (measured at the ends of the diaphragm through the quick-fit pressure test ports) has a corresponding accurate flow rate value, known as the diaphragm Kv value.

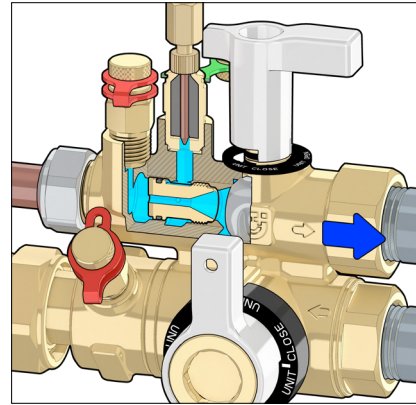

**Use with actuators**

The kit is designed to function with a proportional linear actuator (code 145013). When controlled by a regulator, the valve can modulate the flow rate in accordance with the system thermal load.

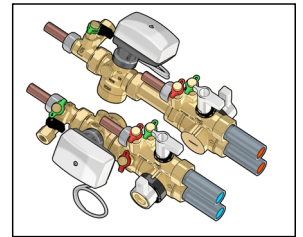

As an alternative to a proportional linear actuator, the valve can also be controlled with a 6565 series ON/OFF type thermo-electric actuator, for simpler temperature control logic.

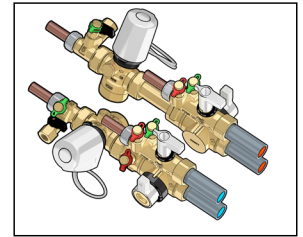

**SIZING**

**Example**

The following design data are adopted:

- Type A** - Ga = 450 l/h - Ha = 10 kPa
- Type B** - Gb = 650 l/h - Hb = 13 kPa
- Type C** - Gc = 900 l/h - Hc = 17 kPa

**Kit size selection**

- Each fan coil is served by a kit for which it is necessary to choose:
- 1- the body size
- 2- the flow rate range and the related flow rate preset.

It is sufficient to identify the correct flow rate range. The following sizes can be chosen:

**Type A and B.**  
Flow rate range H80  
Size DN 20

**Type C.**  
Flow rate range 1H2  
Size DN 20

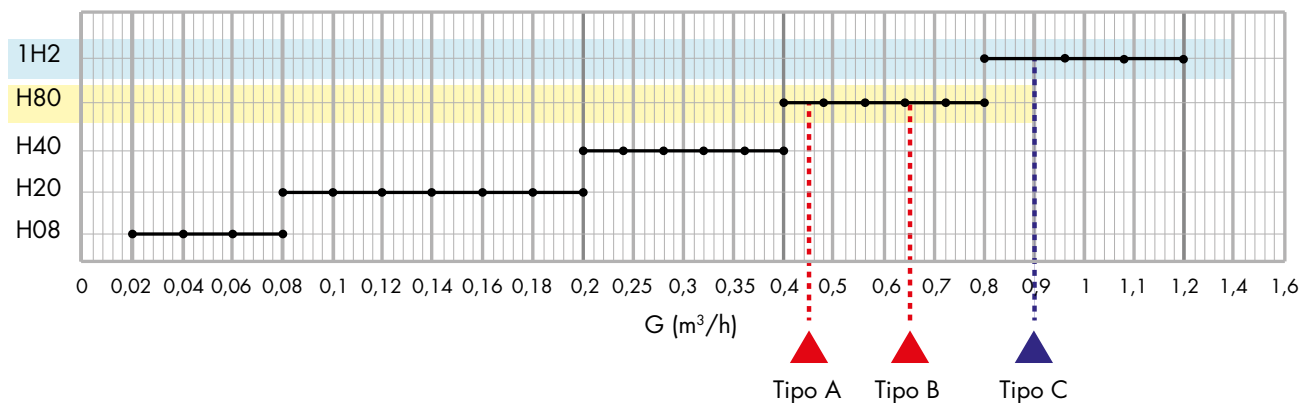
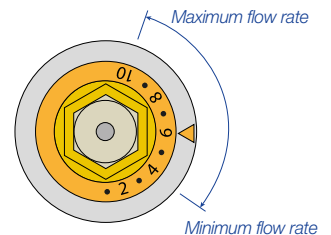

## COMMISSIONING

Using different positions of the three-way ball valves (hereinafter referred to as valve A and valve B), different operation configurations can be obtained.

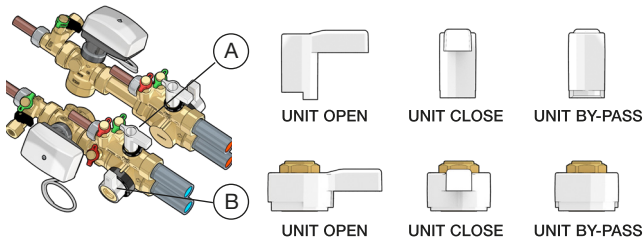

### 1) Wash in by-pass

Clean the main circuit, by simple washing or using specific products, with the exception of the single terminal unit. Place both lever A and lever B on "UNIT BY-PASS".

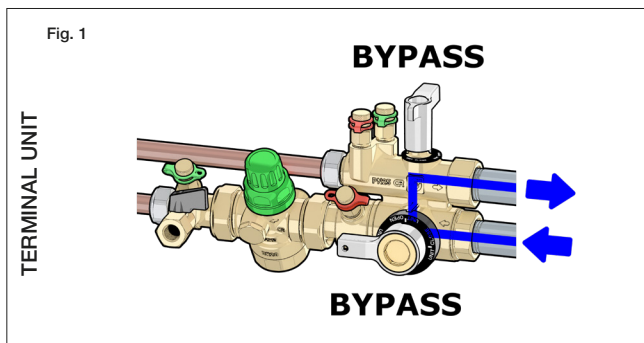

### 2) Terminal unit washing

Position both levers at "UNIT OPEN", close the PICV using the knob and open the drain cock: in this way it is possible to flush the terminal unit using water from the main circuit without it passing through the PICV (Fig. 2A).

In cases where it is necessary, it is possible to wash the terminal unit even with the configuration shown in fig.2B. In this case, set lever A to "UNIT CLOSE" and lever B to "UNIT BY-PASS".

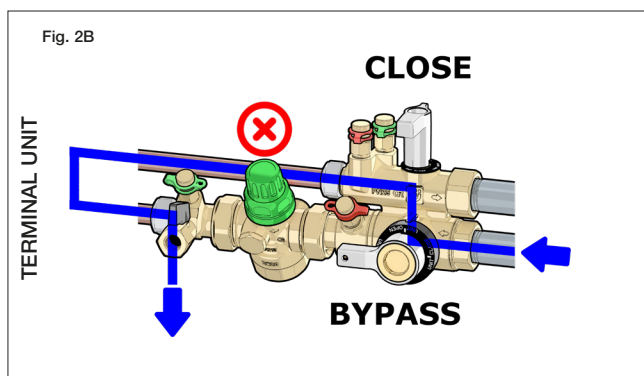
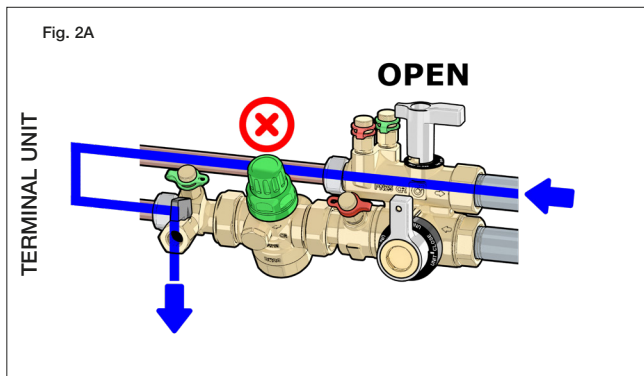

### 3) Strainer cleaning

To clean the strainer position both levers on "UNIT CLOSE".

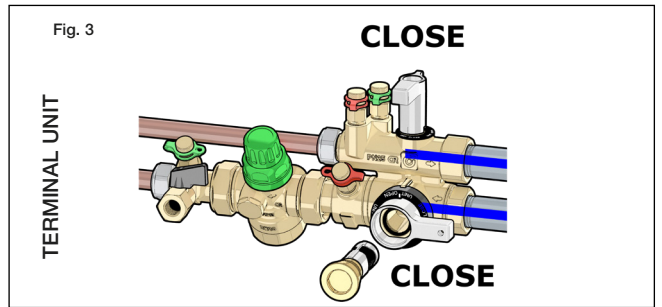

Unscrew the strainer cartridge with a 20 mm spanner, being careful of the water that comes out.

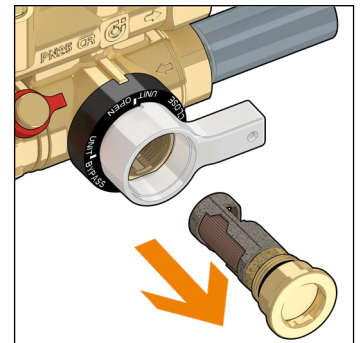

Remove the strainer holder cartridge and clean the strainer under running water.

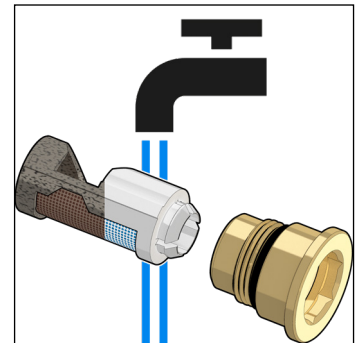

### 4) Filling

Place lever A on "UNIT CLOSE" and lever B on "UNIT OPEN", open the PICV using the appropriate knob. Close the drain cock as soon as the air is completely eliminated.

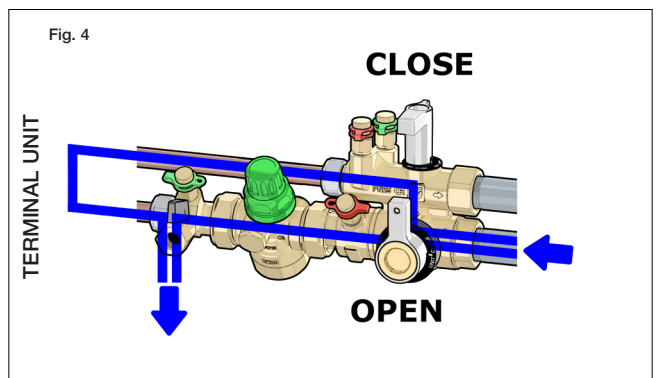

**5) Normal operation**

Normal operation involves positioning both valves on "OPEN". Water passes through the strainer before entering in the terminal unit, protecting the unit against any residues and impurities present in the main circuit water.

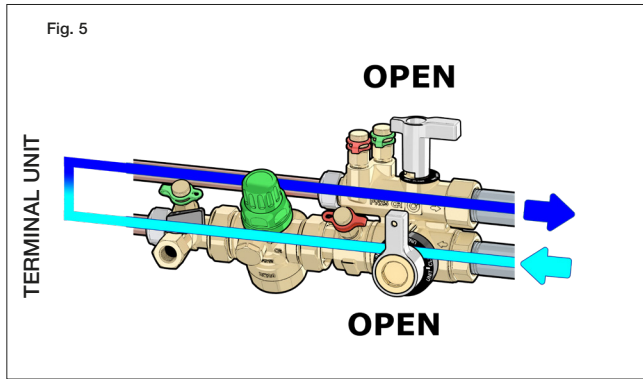

**CAUTION:**

Since it has no insulation, provide a suitable condensation collection system.

**Maximum flow rate regulation**

Adjust the maximum flow rate using the PICV adjustment nut. See section "Maximum flow rate regulation". Check the PICV setting by measuring the flow rate passing through the terminal unit using the Venturi device. See section "Flow rate measurement".

Install the actuator and carry out the electrical connections.

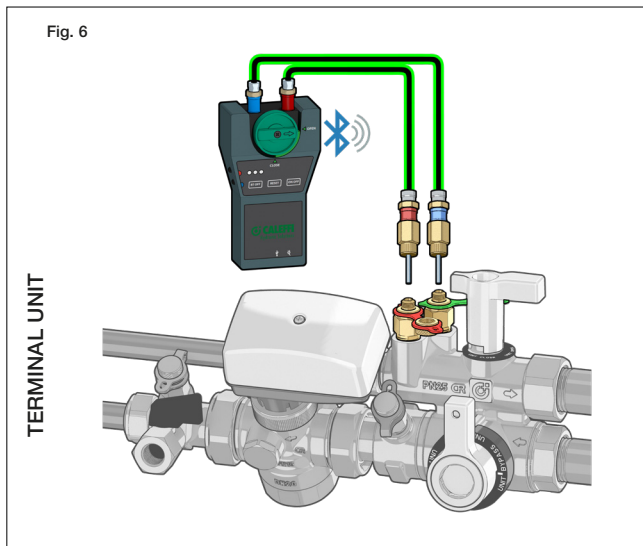
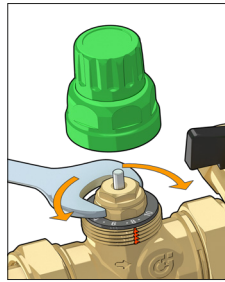

**Additional use configurations**

**Isolate the line**

It is possible to exclude the terminal unit and thus isolate the secondary circuit. This configuration is generally used to perform maintenance on the terminal unit.

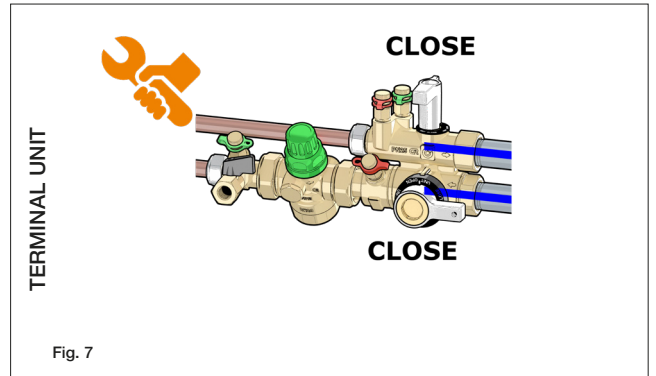

## FLOW RATE REGULATION

### Maximum flow rate regulation

Unscrew the protective cap by hand to gain access to the maximum flow rate adjustment nut (10), which can be turned with a hexagonal key. The locking nut is fixed to a 10-position graduated scale, divided into steps corresponding to 1/10 of the maximum available flow rate, which is also shown on the scale (11). Turn the locking nut to the numerical position corresponding to the required flow rate (design flow rate), referring to the "Flow rate adjustment table". The slot (12) on the valve body is the physical positioning reference. Turning the locking nut (10), which determines the number associated with the "Adjustment position", opens/closes the cross section in the external obturator (13).

Hence, each cross section set on the locking nut corresponds to a specific  $G_{max}$  value.

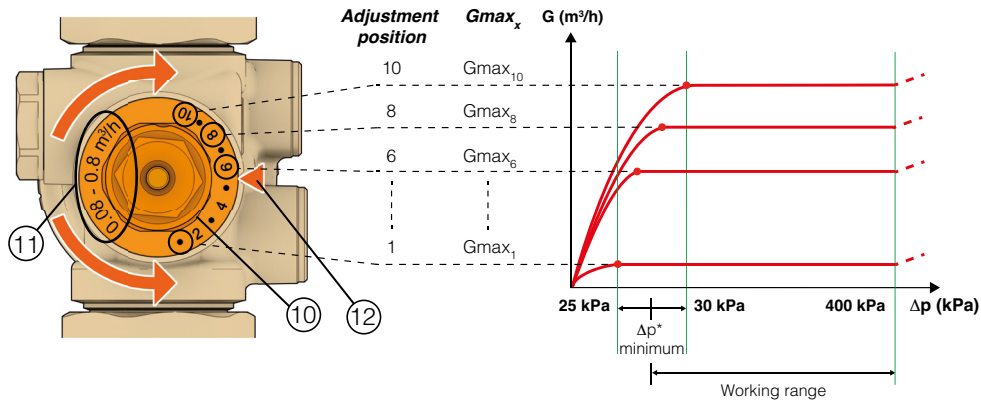
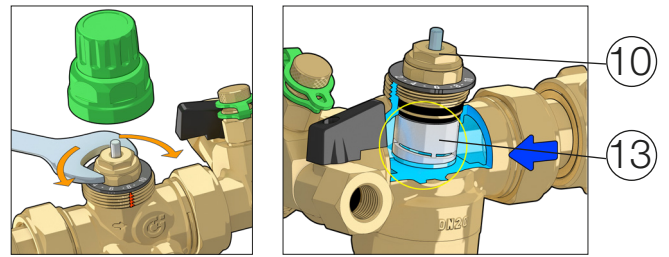

### Automatic flow rate regulation with actuator and external regulator

After regulating the maximum flow rate, it is possible to fit the actuator (0–10 V) to the valve, code 145013.

Under the control of an external regulator the actuator can change the flow rate from the maximum value set (E.g.:  $G_{max_8}$ ) down to the minimum value, depending on the thermal load to be controlled while keeping the systems automatically balanced. The actuator acts on the vertical displacement of the control stem (4). This results in additional opening/closing of the maximum cross section by the internal obturator.

For example, if the maximum flow rate has been set to position 8, the actuator can regulate the flow rate automatically from  $G_{max_8}$  to completely closed (zero flow rate).

### Valve regulating characteristics

The valve regulating characteristic is of the linear type. An increase or decrease in the valve opening cross section corresponds to a directly proportional increase or decrease of the hydraulic characteristic  $K_v$  of the device.

The motor is factory configured with linear adjustment.

It is possible to obtain an equal-percentage adjustment (see diagram below) by setting the actuator (code 145013) for this operation by means of the dedicated switch inside it. (see specific instruction sheet). In this way the control signal is managed to obtain an equal percentage adjustment.

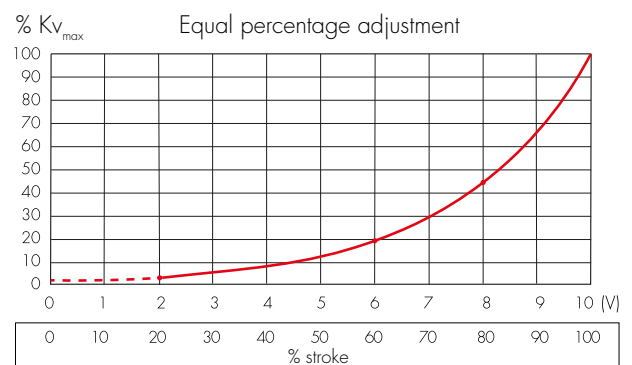
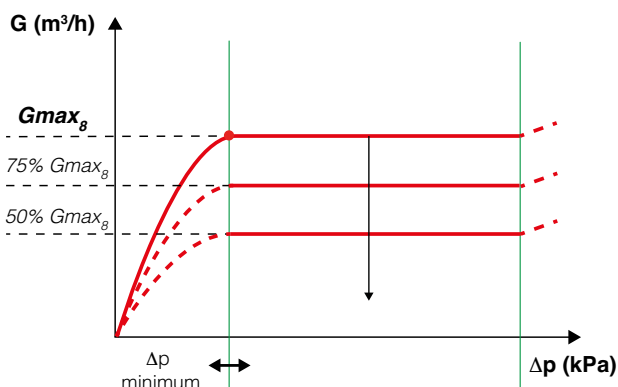
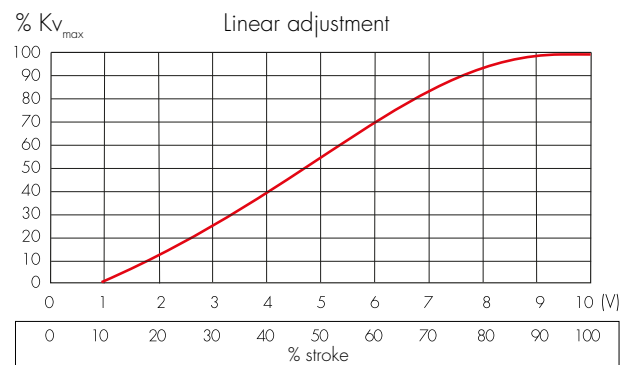
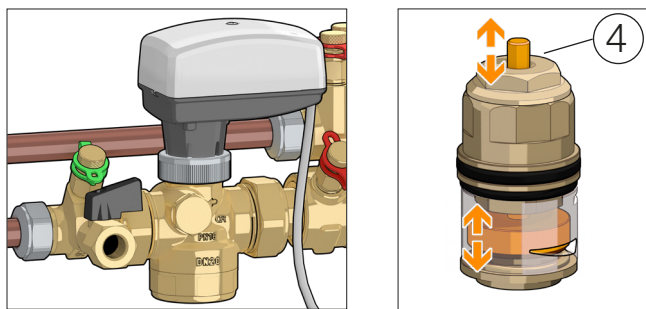



## FLOW RATE MEASUREMENT

Connect a differential pressure meter to the Venturi device pressure test ports on the kit.

Reading the  $\Delta p$  on the measuring device, to obtain the flow rate  $G$  you can refer to the characteristic Venturi diagram of the size being used. Or, analytically, you can calculate the flow rate by applying the equation:

$$G = K_{V_{Venturi}} \times \sqrt{\Delta p_{Venturi}} \quad (1.1)$$

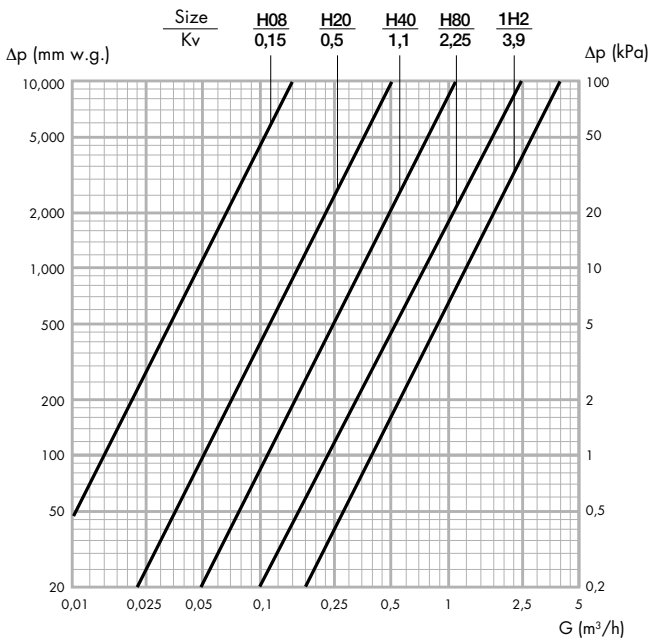
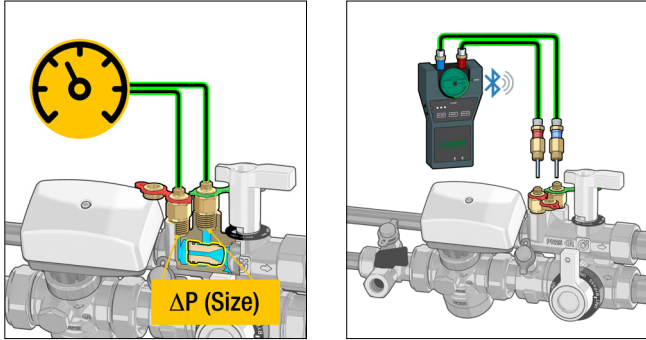

### Example of flow rate measurement

Reading a  $\Delta p_{Venturi}$  of 4,5 kPa (red line) on an H80 valve and using the characteristic Venturi chart for the valve in question, the x-axis gives a flow rate of 0,5 m³/h (blue line).

Instead, to proceed analytically using the ratio (1.1), a measurement of  $\Delta p_{Venturi}$  equal to 4.5 kPa (bearing in mind that the  $K_{V_{Venturi}}$  of the H40 valve is equal to 2,25) leads to the calculation of a flow rate

$$G = 2,25 \times \sqrt{0,045} = 0,48 \sim 0,5 \text{ m}^3/\text{h} \quad (1.1)$$

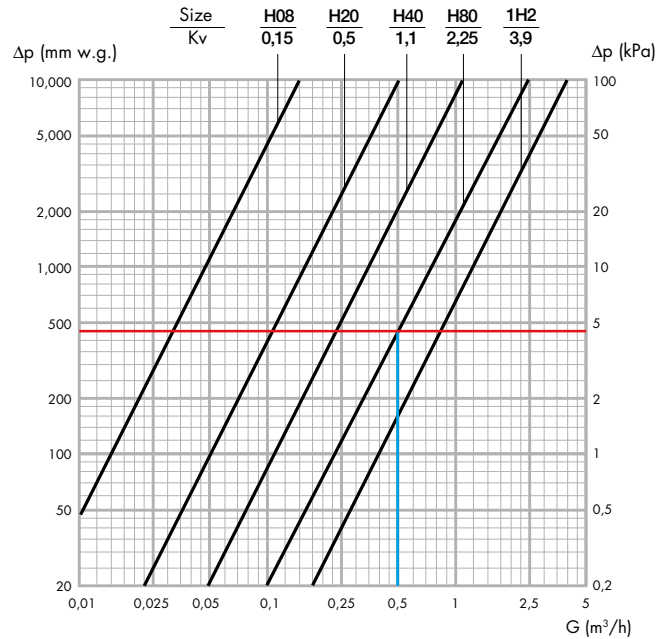

### Example of correction for liquid with different density

Liquid density  $\rho' = 1,1 \text{ Kg/dm}^3$   
 Measured pressure drop  $\Delta p_{Venturi} = 4,5 \text{ kPa}$   
 Reference pressure drop  $\Delta p' = 4,5 / 1,1 = 4,1 \text{ kPa}$   
 With this value you use the Venturi diagram for the dimension used or the formula (1.1) and obtain the corresponding flow rate (G) equal to 0,47 m³/h.

## MEASUREMENTS

### $\Delta p$ measurement

The  $\Delta p$  of the valve can be measured during commissioning (using the Caleffi instrument code codice 130005/6) to check that it is working in the correct  $\Delta p$  range.

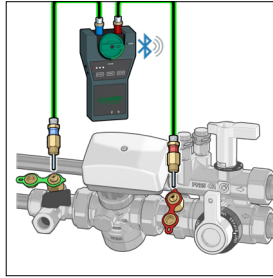

### Terminal unit $\Delta p$ measurement

Connecting the measuring instrument to the low pressure connection of the Venturi device and to the high pressure connection of the PICV it is possible to measure the working  $\Delta p$  of the terminal unit circuit.

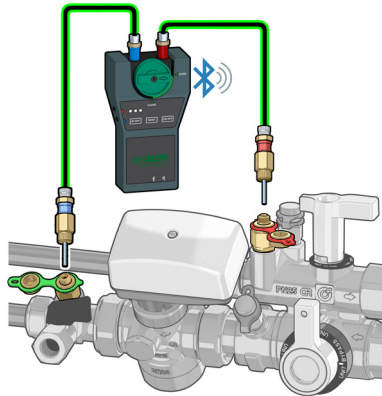

### Terminal unit $\Delta T$ measurement

Connecting the measuring instrument by means of appropriate probes (optional) to any low pressure test port connection of the Venturi device and to one of the PICVs it is possible to measure the working  $\Delta T$  of the terminal unit circuit.

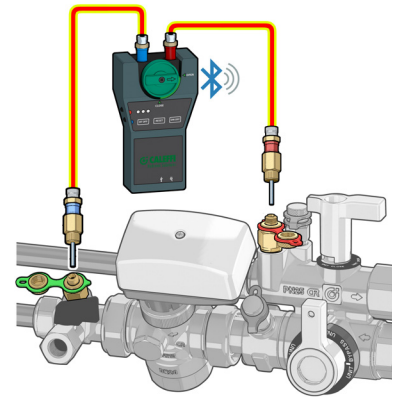

## APPLICATION DIAGRAMS

### Installation for water side control fan coil units

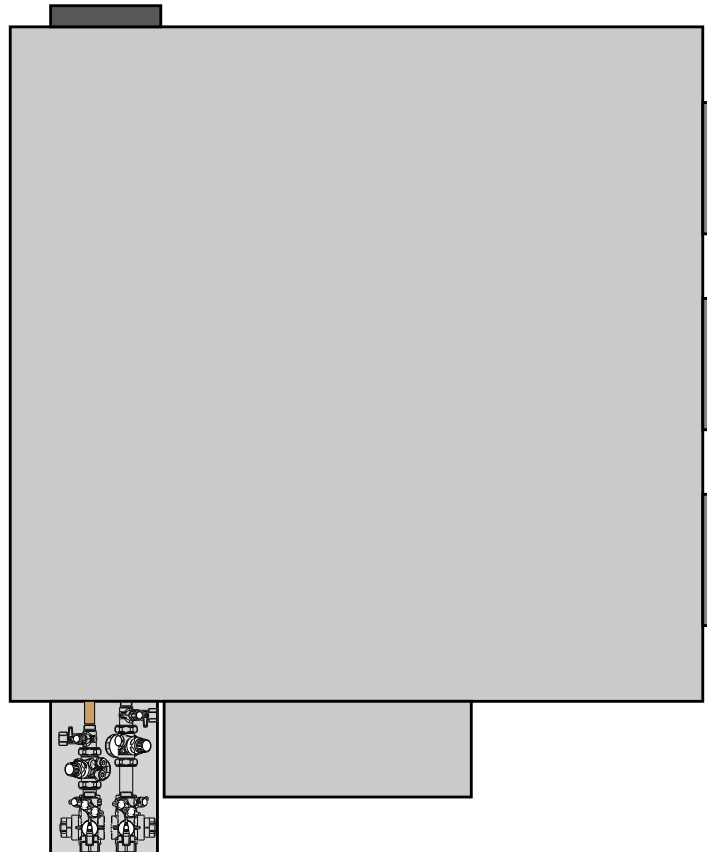

## ACCESSORIES



**145**

Proportional linear actuator for 145 series FLOWMATIC® control valve and 149 series kit.  
 Electric supply: 24 V (AC/DC).  
 Control signal: 0(2)–10 V, 0(4)–20 mA.  
 Feedback signal: 0–10 V.  
 Ambient temperature range: 0–50 °C.  
 Protection class: IP 54.  
 Connection: M 30 p.1,5.  
 Supply cable length: 2 m.

Code	Voltage
145013	24

**130**

Electronic flow rate and differential pressure meter. Supplied with shut-off valves and connection fittings. May be used for  $\Delta p$  measurements and setting balancing valves.

Bluetooth® transmission between  $\Delta p$  meter and remote control unit. Versions with remote control unit with Android® application for Smartphone and Tablet.  
 Measurement range: 0–1000 kPa.  
 Static  $P_{max}$ : 1000 kPa.  
 Battery electric supply.



**6565**

Proportional thermo-electric actuator for 145 series FLOWMATIC® control valve and 149 series kit.

**Quick-coupling installation with fixing clip adapter.**

Normally closed.  
 Electric supply: 24 V (AC/DC).  
 Running power consumption: 1,2 W.  
 Control signal: 0–10 V.  
 Feedback signal: 0–10 V.  
 Ambient temperature range: 0–60 °C.  
 Protection class: IP 54.  
 Connection: M 30 p.1,5.  
 Electric supply cable: 1 m.



Code	Voltage V
656524	24

**6565**

Thermo-electric actuator for 145 series FLOWMATIC® control valve and 149 series kit.

**Quick-coupling installation with fixing clip adapter.**

Normally closed.  
 Electric supply: 230 V (AC) or 24 V (AC)/(DC).  
 Running power consumption: 1 W.  
 Control signal: ON/OFF.  
 Ambient temperature range: 0–60 °C.  
 Protection class: IP 54.  
 Connection: M 30 p.1,5.  
 Electric supply cable: 1 m.



Code	Voltage V
656502	230
656504	24



**Caleffi Smart Balancing**

Smartphone app available.

Download the version for your Android® mobile phone.

Code

130006	complete with remote control unit, with Android® application
130005	without remote control unit, with Android® application

**Bluetooth® transmission to the terminal with Android® app**

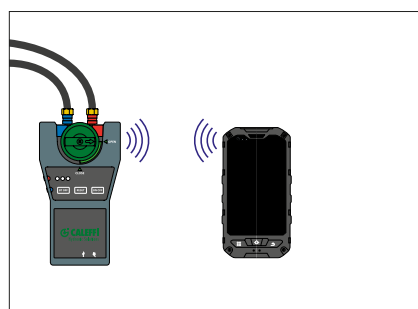

**Bluetooth® transmission to Smartphone/Tablet with Android® app**

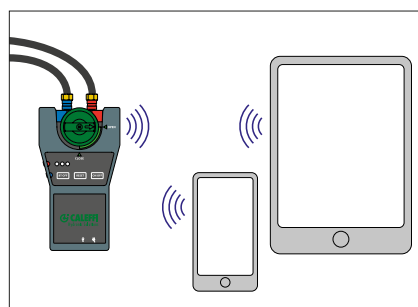

## SPECIFICATION SUMMARY

### 149 series

Connection and regulation kit for HVAC terminal units in heating and cooling systems. Complete with: pressure independent control valve, three-way shut-off valves, integrated by-pass, Venturi device with pressure test ports and filter cartridge. Size DN 20. Main connections on system side 1 3/4"; terminal unit side Euroconus 3/4" M. Connections centre distance: 40 mm. Pressure test port connections 1/4" F (ISO 228-1) with plug. Connection for actuators code 145013 and 6565 series thermo-electric actuators M30 p.1,5.

Flow rate regulation range of the kit with Venturi device: 0,02–0,08 m<sup>3</sup>/h (H08); 0,08–0,20 m<sup>3</sup>/h (H20); 0,20–0,40 m<sup>3</sup>/h (H40); 0,40–0,80 m<sup>3</sup>/h (H80); 0,60–1,20 m<sup>3</sup>/h (1H2).

Maximum working pressure 25 bar. Maximum differential pressure with actuator code 145013 (and 6565 series) installed 4 bar. Nominal working  $\Delta p$  range 25–400 kPa. Working temperature range -10–120 °C. Ambient temperature range 0–50 °C. Strainer mesh size 800  $\mu$ m. Medium: water and glycol solutions; maximum percentage of glycol 50%. Dezincification resistant alloy body and adjustment headwork; stainless steel strainer mesh; EPDM diaphragm, obturator and seals.

### Code 145013

Proportional linear actuator for 145 series control valve. Proportional linear actuator. Electric supply 24 V (AC)/(DC). Power consumption 2,5 VA (AC), 1,5 W (DC). Control signal 0–10 V. Feedback signal: 0–10 V. Protection class IP 54. Ambient temperature range 0–50 °C. Connection M30 p. 1,5. Supply cable length 2 m.

### Code 656524

Proportional thermo-electric actuator for 145 series control valve. Electric supply 24 V (AC)/(DC). Power consumption 1,2 W. Control signal 0–10 V. Feedback signal: 0–10 V. Protection class IP 54. Ambient temperature range 0–60 °C. Connection M30 p. 1,5. Supply cable length 1 m. Automatic valve stroke detection. Operating time (open-close) approx. 200 seconds.

### 6565 series

Thermo-electric actuator. Normally closed. Electric supply 230 V (AC); 24 V (AC); 24 V (DC). Running power consumption 1 W. Control signal ON/OFF. Protection class IP 54. Ambient temperature range 0–60 °C. Supply cable length 1 m. Operating time (open-close) approx. 240 seconds.

### Code 130005

Electronic flow rate and differential pressure meter without remote control unit, with Android® application. Supplied with shut-off valves and connection fittings. Differential pressure 0–1000 kPa. Static pressure: < 1000 kPa. System temperature: -30–120 °C.

### Code 130006

Electronic flow rate and differential pressure meter with remote control unit and Bluetooth® transmission. Supplied with shut-off valves and connection fittings.

Differential pressure 0–1000 kPa. Static pressure: < 1000 kPa. System temperature: -30–120 °C.

*We reserve the right to make changes and improvements to our products and the related technical data in this publication, at any time and without prior notice.*