

EA type anti-contamination check valves with built-in shut-off



324 series



Function

The anti-contamination check valve with built-in shut-off is a protective plumbing device capable of preventing the backflow of polluted water into the mains water system. This may occur due to changes in pressure in the distribution network that cause water to flow backwards. The check valve, which is fitted between the mains and the user system in water distribution systems, prevents any contact between the water in the two systems, as it closes automatically whenever backflow conditions occur.

Thanks to its special patented design, the single valve makes it possible to carry out maintenance on and replace the built-in check valve, as well as check its water tightness.

Dezincification resistant material with very low lead contents (Low Lead)

The material used to make the check valve is perfectly in line with the new regulatory provisions concerning contact with potable water. This is an innovative alloy with very low lead contents and dezincification resistant properties.

PATENT PENDING

Product range

324 series Anti-contamination check valve with built-in shut-off, EA type _____ sizes DN 15 (1/2" M) and DN 20 (3/4" M)
 Cod. 324250 Anti-contamination check valve with built-in shut-off, EA type _____ size DN 20 (3/4" M x 3/4" F with nut)
 Cod. 324110/120 Anti-contamination check valve with built-in shut-off, EA type _____ size DN 15 (Ø 15) e DN 20 (Ø 22) for copper pipe

Technical specifications

Materials

Body: "Low Lead" dezincification resistant alloy CR EN 12165 CW724R
 Check valve: POM
 Check valve spring: stainless steel
 Check valve seal: EPDM
 Ball: "Low Lead" dezincification resistant alloy CR EN 12164 CW724R
 Ball control stem: "Low Lead" dezincification resistant alloy CR EN 12164 CW724R
 Ball seal seat: PTFE
 Control lever: special galvanized steel
 Control stem seals: EPDM
 Test ports cap: PA66G30

Performance

Medium: potable water
 Max. working pressure: 10 bar
 Check valve minimum opening pressure (Δp): 0.5 kPa
 Max. working temperature: 65°C
 Certification in compliance with standard: EN 13959 / EN 13828 BRL-K629
 Connections: 1/2" - 3/4" M (ISO 228-1)
 (324250) 3/4" M (ISO 228-1) x 3/4" F with nut
 (324110 - 324120) Ø 15 - Ø 22 for copper pipe
 Test port connections: 1/4" F (ISO 228-1)

Dimensions

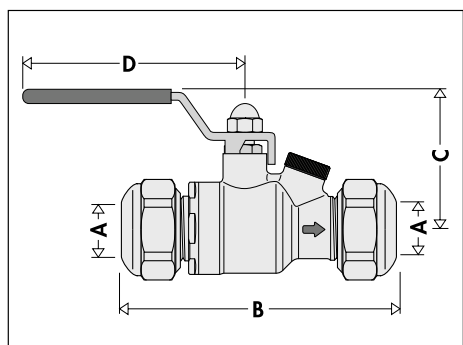
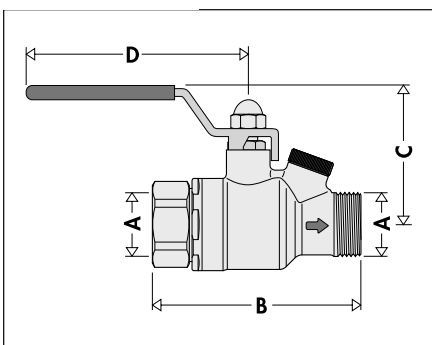
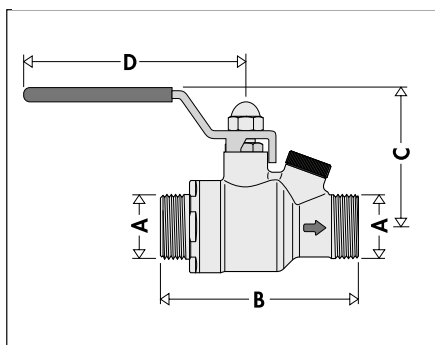

Code	DN	A	B	C	D	Mass (kg)
324140	15	1/2"	81	56	100	0,432
324150	20	3/4"	82	56	100	0,453

Code	DN	A	B	C	D	Mass (kg)
324250	20	3/4"	86	56	100	0,528

Code	DN	A	B	C	D	Mass (kg)
324110	15	Ø 15	99	56	100	0,482
324120	20	Ø 22	99	56	100	0,512

Hydraulic characteristics

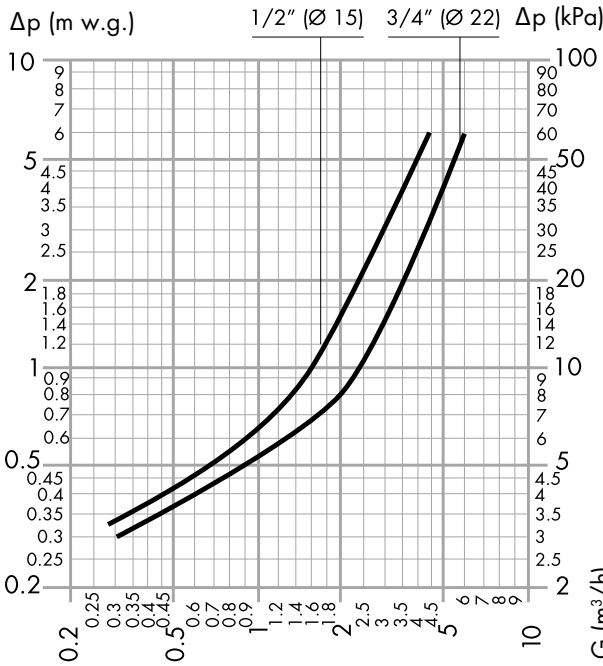

Code		DN	Internal check valve DN	Kv (m³/h)	
324140	—	324110	15	20	5.5
324150	324250	324120	20	20	8.3

Backflow

Potable water, flowing in the mains supply network, may suffer from hazardous pollution mainly caused by the return of contaminated medium from downstream systems directly connected to the main supply. This phenomenon, termed “backflow”, occurs when:

- the pressure in the mains system is lower than the pressure in the downstream hydraulic circuit (back syphonage). This situation may occur when there is a pipe breaking in the mains system or when demand on the mains supply network by consumers is very heavy.
- the pressure in the downstream circuit rises (counter pressure/downstream overpressure) due, for example, to a water inlet pumped from a well.

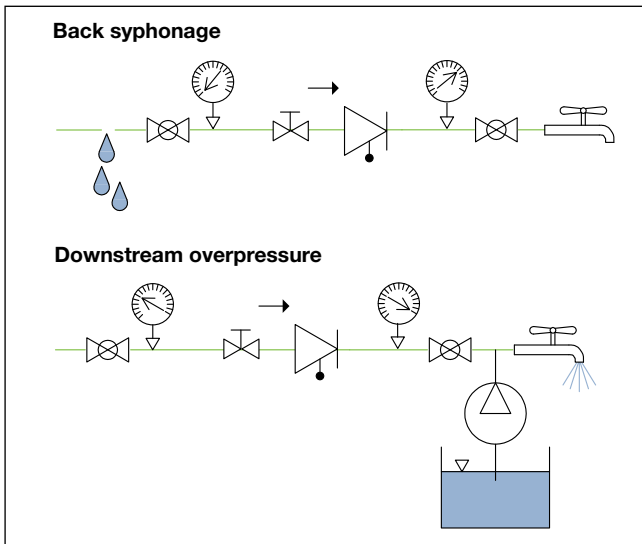

Risk assessment

Given the potential danger of the phenomenon and the requirements of current regulations, the risk of pollution by backflow must be assessed on the basis of the type of system and the characteristic of the medium that flows in it. An appropriate backflow prevention device must be selected on the basis of that assessment performed by the system designer and the mains supply Company. The device must be located along the supply line at those points at risk of backflow which would be hazardous to human health.

Application of the EA type anti-pollution check valve with reference to European standard EN 1717 and EN 13959

The use of EA type anti-pollution check valve is governed by the new European standards relating to the prevention of pollution caused by backflow. The reference standard is EN 1717: 2000 “Protection against pollution of potable water in water installations and general requirements of devices to prevent pollution by backflow”. This standard classifies the water in the systems according to the level of risk it represents for human health.

- Category 1:** Water to be used for human consumption coming directly from a potable water distribution system.
- Category 2:** Fluid presenting no human health hazard, as per 1, the quality of which can have undergone a change in taste, odour, colour or temperature.
- Category 3:** Fluid representing some human health hazard due to the presence of one or more harmful substances.
- Category 4:** Fluid presenting a human health hazard due to the presence of one or more “toxic” or “very toxic” substances or one or more radioactive, mutagenic or carcinogenic substances.
- Category 5:** Fluid presenting a human health hazard due to the presence of microbiological or viral elements.

According to this classification, suitable backflow prevention devices must be fitted in water distribution circuits.

EA type anti-pollution check valves can be used to offer protection against the risk of water contamination up to category 2. For category 3 water, it is necessary to use a CA type backflow preventer.

The table below, called the “Protection matrix”, associates the various types of system with the related fluid categories, and was created based on the indications provided in European standard EN 1717 and in Local Regulations. The table is not comprehensive, and checks should be conducted at the time of application to ensure compliance with any local standards or regulations.

The European standard EN 13959 – “Anti-pollution check valves from DN 6 to DN 250. Family E, type A, B, C and D.” defines the functional, dimensional and mechanical requirements of anti-pollution check valves.

Protection matrix		
System type	Cat. medium	
	2	3
General		
Hot and cold water mixing devices in domestic water systems	*	
Water cooling devices for air conditioning units, without additives	*	
Filling of heating systems, without additives		*
Domestic water softeners regenerated with common salt	*	
Commercial water softeners (only regenerated with common salt)		*
Water in sinks, baths and showers	*	
Domestic dishwashers and washing machines		*
Domestic, residential or commercial gardens		
Hand-held fertiliser sprayers for use in domestic gardens		*
Catering		
Automatic dispensers without injection of ingredients or CO2	*	
Ice-making machines	*	
Large kitchen machines with automatic filling systems	*	
Medical		
Domestic dialysis machines		*

Certification

The 324 series anti-contamination check valves are certified to BRL-K269 by the body KIWA, in accordance with the EN 13959 and EN 13828 standards.

Operating principle

The anti-pollution check valve with built-in shut-off valve is comprised of a valve body (1), a check valve (2), two test ports (3) – one downstream for operation checks and one downstream for system pressure testing – a shut-off ball valve (4) with control lever (5). The check valve (2) delimits two distinct zones: one upstream or at the inlet (A), and one downstream or at the outlet (B).

Operating conditions

Three possible operating conditions can be obtained according to the position of the control lever:

- 1) lever longitudinal to the valve: normal operating conditions
- 2) lever perpendicular to the valve, rotated clockwise through 90° relative to the longitudinal position: EA check valve operation check
- 3) lever perpendicular to the valve, rotated anti-clockwise through 90° relative to the longitudinal position: operation access to EA check valve for maintenance or replacement.

Correct flow conditions

In correct flow conditions, the check valve (2) opens automatically when the pressure in the flow direction upstream (A) is greater than the downstream value (B).

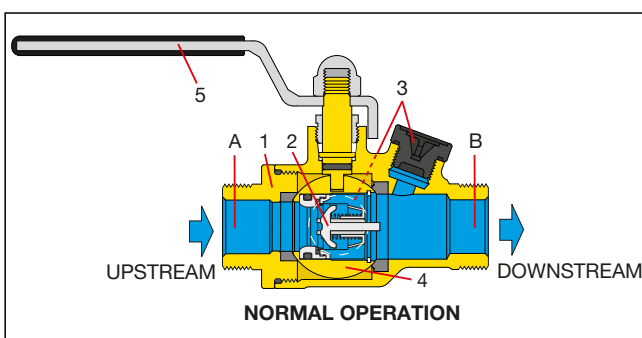

No flow conditions

The check valve (2) closes in advance under the action of the force exerted by the spring when the pressure downstream (B) begins to equal the value upstream (A), after the flow has stopped.

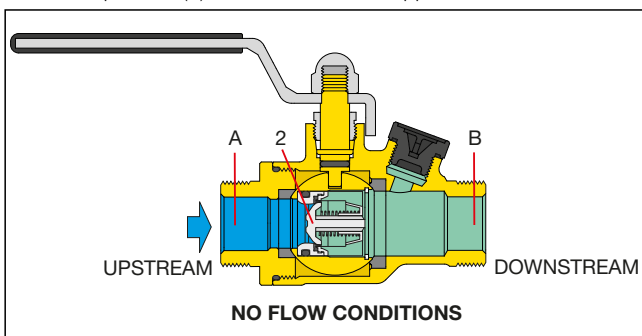

Upstream pressure loss

The check valve (2) remains closed, preventing water which has already been sent to the user from flowing back towards the public network.

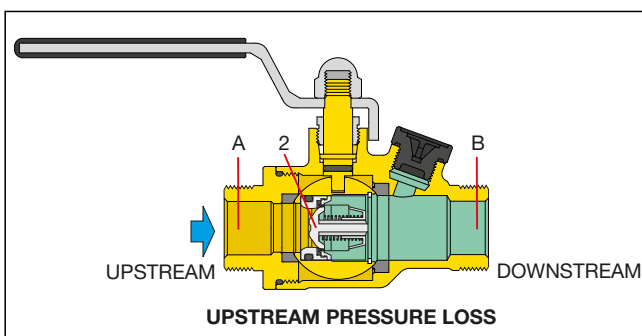

Downstream pressure increase

If the pressure in the downstream zone (B) increases until it exceeds the upstream pressure value (A), the check valve (2) remains closed, thus preventing water that has already been sent to the user from flowing back towards the mains water system.

Installation and maintenance procedures

For installation and inspection, refer to the indications in the previous pages for type EA and EC devices.

Operation check

To test the seal of the check valve, check that the valve closes each time the pressure in the upstream water supply drops, thus preventing water from the system flowing back into the water supply line:

- to maintain pressure in the installation in the absence of flow, close all shut-off valves or users downstream of the valve. Use the downstream test port to check that the pressure is above 0,5 bar; The pressure gauge, supplied as an optional item, can be used to test system pressure downstream of the check valve.
- close the built-in shut-off valve, rotating it clockwise through 90° relative to the longitudinal position, and open the check valve test port. The flow should stop after the small amount of medium contained in the valve body between the shut-off and pressure test port has drained off;
- if not, check the seal of the built-in shut-off valve: if this valve is sealing correctly but the flow from the test port continues, replace the check valve, as the flow can only be caused by imperfect watertightness of the valve.

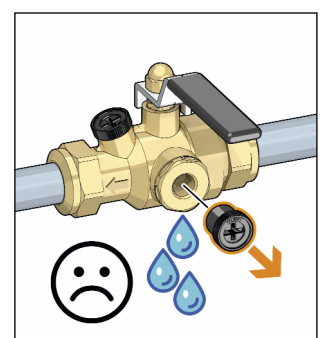
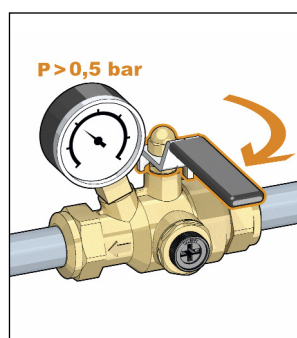

Replacement of the check valve

Thanks to the special patented design, all operation check or replacement operations can be carried out using just one shut-off valve:

- position the lever perpendicular to the valve body by raising it slightly and rotating it anti-clockwise through 90° relative to the longitudinal position;
- open the brass side cap;
- remove the snap ring and the O-ring;
- use pliers to remove the snap ring, taking care not to damage it. Carry out the maintenance operations, position the original or replacement check valve in its seat and refit by reversing the removal procedure.

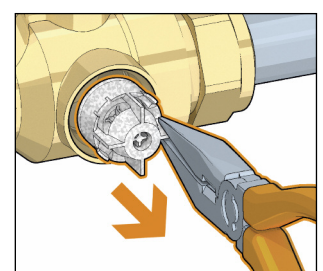
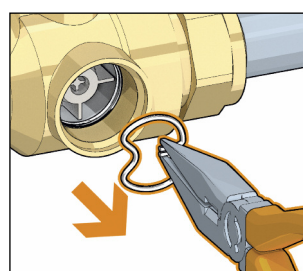
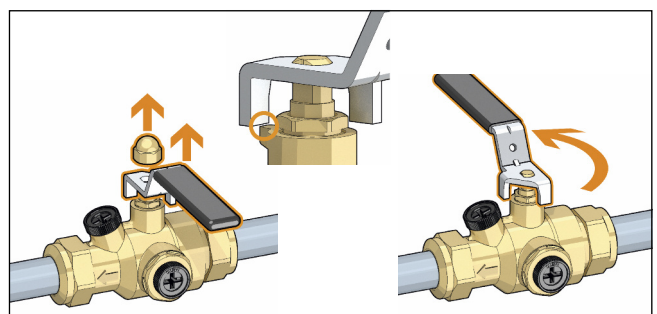

Installation and inspection procedures

EA TYPE

Installation

Before installation, make sure that the device is suitable for protecting the supply system, in relation to the type of fluid used in the system. The controllable check valve should be installed in an accessible position downstream of a shut-off valve. Before installing, flush the pipe with a high flow rate water jet: lack of cleaning can easily result in impaired operation of the product. Inspection and maintenance (operation check) procedures should be carried out at least once a year, in accordance with EN 806-5.

1	Upstream shut-off valve
2	Controllable check valve
3	Downstream shut-off valve

A	Upstream test port
B	Downstream test port

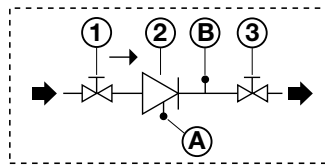

In the 324 series, a single device contains all of the control components

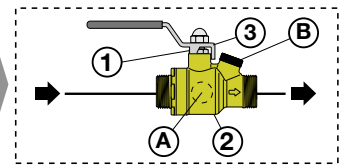

Inspection

Check whether the installation standards still require the application of the same device for the type of medium used in the system. Make sure that the hazard level of the medium in the system has not altered over time. Check that the surrounding environment is clean, the valve is accessible and that there are no leaks, corrosion or deterioration.

Application diagrams

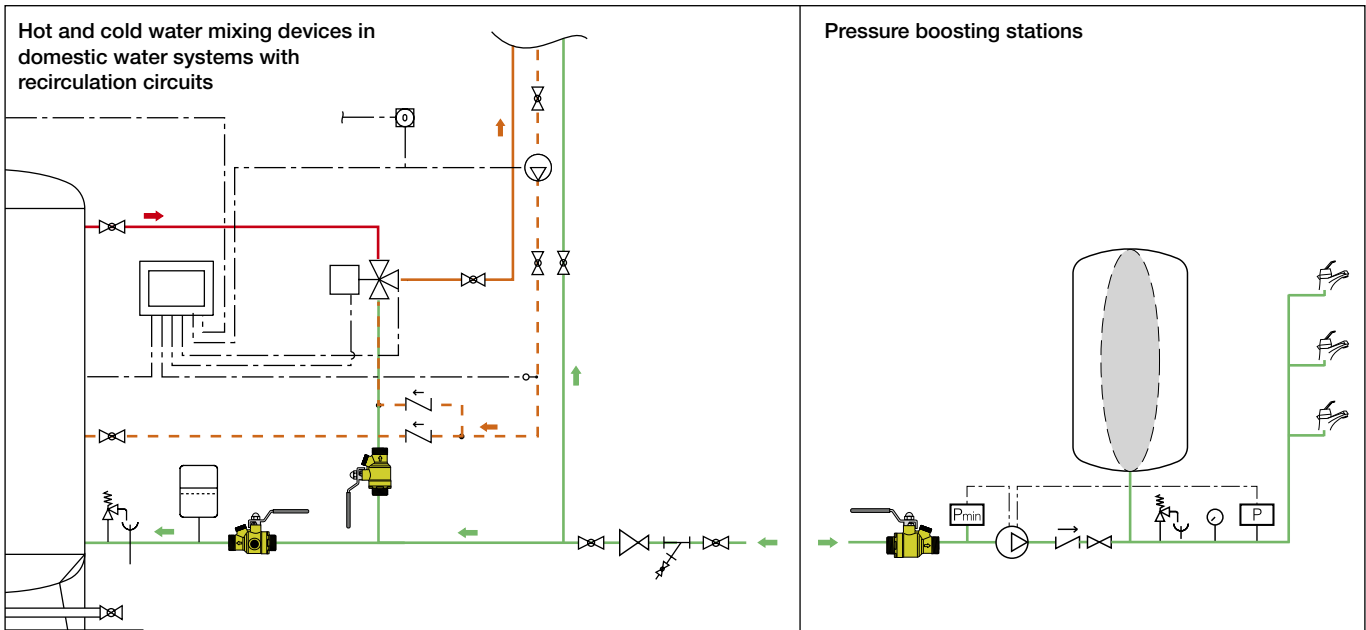

SPECIFICATION SUMMARY

324 Series

Check valve with built-in shut-off. EA type. 1/2" (1/2" and 3/4") F threaded connections, internal check valve DN 15 (DN 15 and DN 20). Certification to EN 13959 and EN 13828 standards. Dezincification-resistant "Low Lead" alloy body. POM check valve. Stainless steel spring. EPDM O-Ring seals. Medium drinking water. Maximum working pressure 10 bar. Minimum opening pressure for check valve 0,5 kPa. Maximum working temperature 65°C. Test port caps in PA66G30, 1/4" F connections.

Code 324250

Check valve with built-in shut-off. EA type. 3/4" M x 3/4" F threaded connections with nut, internal check valve DN 20. Certification to EN 13959 and EN 13828 standards. Dezincification-resistant "Low Lead" alloy body. POM check valve. Stainless steel spring. EPDM O-Ring seals. Non-asbestos fibre NBR union seal. Medium drinking water. Maximum working pressure 10 bar. Minimum opening pressure for check valve 0,5 kPa. Maximum working temperature 65°C. Test port caps in PA66G30, 1/4" F connections.

Code 324110/120

Check valve with built-in shut-off. EA type. Ø 15 connections for copper pipe (Ø 15 and Ø 22), internal check valve DN 15 (DN 15 and DN 20). Certification to EN 13959 and EN 13828 standards. Dezincification-resistant "Low Lead" alloy body. POM check valve. Stainless steel spring. EPDM O-Ring seals. Non-asbestos fibre NBR union seal. Medium drinking water. Maximum working pressure 10 bar. Minimum opening pressure for check valve 0,5 kPa. Maximum working temperature 65°C. Test port caps in PA66G30, 1/4" F connections.

We reserve the right to make changes and improvements to the products and related data in this publication, at any time and without prior notice.