

# “L” pattern adjustable thermostatic mixing valve

## 5200 series



01266/16 GB



### Function

The thermostatic mixing valve is used in systems that produce domestic hot water. Its function is to maintain the temperature of the mixed water supplied to the user constant at the set value despite variations in the hot and cold water supply conditions at the inlet. The mixing valve also features a thermal shut-off function that operates in the event of a cold water supply failure at the inlet.

This series of mixing valves provides the mixed water outlet in line with the hot water inlet from the storage, facilitating trouble-free connection and reducing the space required for installation.



**kiwa**

### Product range

5200 series Adjustable thermostatic mixing valve with knob, complete with inlet strainers and check valves \_\_\_ DN 15 (1/2"), DN 20 (3/4") and DN 25 (1")

### Technical specifications

#### Materials

Body: dezincification resistant alloy **CR**  
EN 1982 CC768S  
Obturator: PSU  
Springs: stainless steel EN 10270-3 (AISI 302)  
Seals: EPDM  
Knob: ABS

#### Performance

Adjustment temperature range: 35–65°C  
Accuracy: ±2°C  
Max. working pressure (static): 10 bar  
Max. working pressure (dynamic): 5 bar  
Max. inlet temperature: 90°C  
Max. inlet pressure ratio (H/C or C/H): 2:1  
Minimum temperature difference between hot water inlet and mixed water outlet, to ensure thermal shut-off function: 15°C  
Min. flow rate for stable operation:  
4 l/min (DN 15 and DN 20)  
6 l/min (DN 25)

Connections: 1/2", 3/4", 1" M (ISO 228-1) with union

### Dimensions

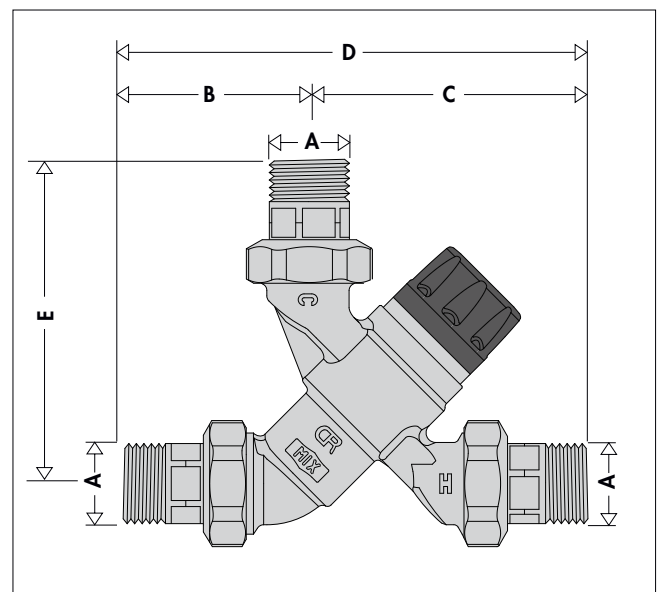

Code	A	B	C	D	E	Mass (kg)
520040	1/2"	58,5	87,5	146	102,5	0,783
520050	3/4"	59,5	88,5	148	103,5	0,900
520060	1"	76,5	115,5	192	133,5	1,708

## Legionella - point of distribution

According to the most recent legislation and standards, in order to prevent the growth of the dangerous Legionella bacterium in centralised systems producing domestic hot water with storage, the hot water must be stored at a temperature of at least 60°C. At this temperature it is certain that the growth of the bacteria will be totally eliminated.

The adjacent diagram shows the behaviour of *Legionella Pneumophila* bacteria as the temperature conditions of the water containing the bacteria vary. To ensure correct thermal disinfection, it is necessary to go up to values of at least 60°C.

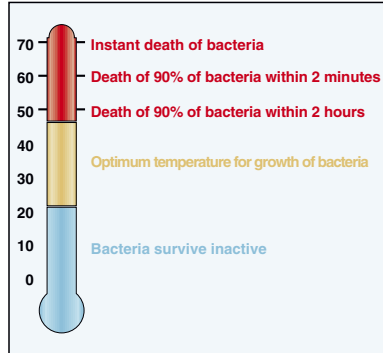

In this type of system, it often happens that the temperature at the storage outlet is unstable and highly variable. This occurs because of multiple operating conditions, in terms of pressure and heat exchange with the primary energy source and the drawn flow rate.

For all these reasons, therefore, a thermostatic mixing valve must be installed on the hot water storage outlet line, at the inlet point of the distribution system, which is able to:

- reduce the temperature at the point of distribution to a value lower than that of the storage, in a controlled way to make it suitable for domestic use,
- have a temperature adjustment range that makes it possible to perform a thermal disinfection of the system, should this be necessary,
- allow the temperature to be adjusted at the desired value, with a tamper-proof locking system,
- keep the distribution temperature constant despite variations in temperature, inlet pressure and drawn flow rate,
- have a thermal shut-off function that operates in the event of a cold water supply failure at the inlet.

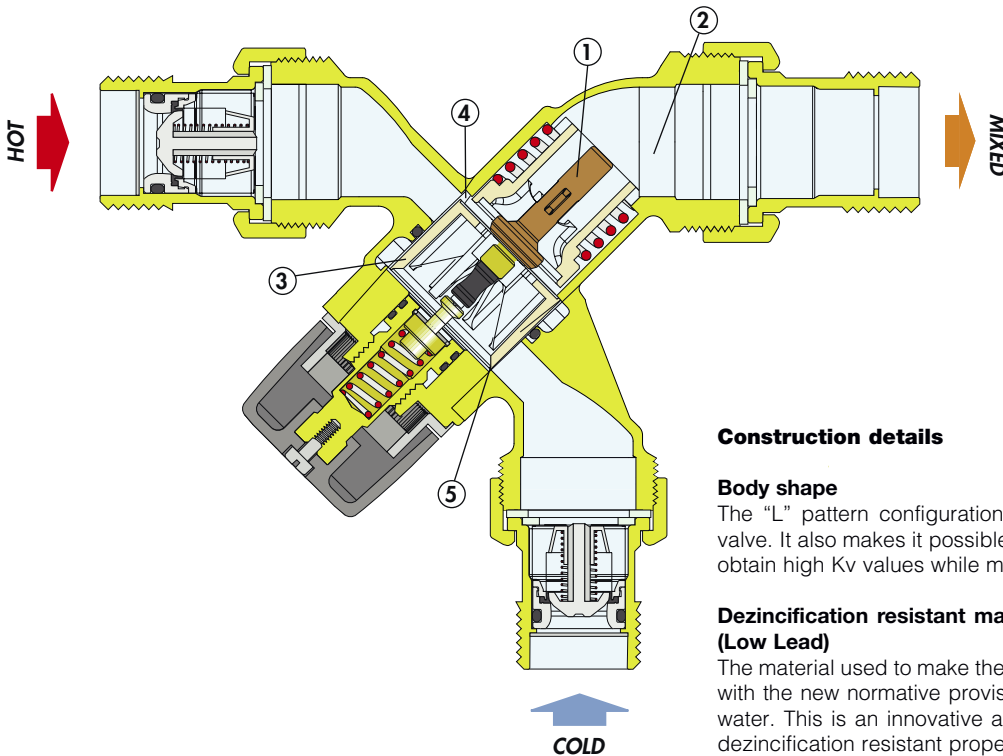

### Construction details

#### Body shape

The "L" pattern configuration facilitates installation of the mixing valve. It also makes it possible to optimise fluid dynamics and thus obtain high Kv values while minimising head losses.

#### Dezincification resistant material with very low lead contents (Low Lead)

The material used to make the mixing valve body is perfectly in line with the new normative provision concerning contact with potable water. This is an innovative alloy with very low lead contents and dezincification resistant properties.

#### Anti-scale materials

The materials used in constructing the mixing valve were selected to eliminate seizing due to limescale deposits. All functional parts have been made using a special anti-scale material with low friction coefficient, which ensures over time performance.

#### Thermal shut-off

In the event of accidental cold water supply failure, the obturator shuts off the hot water passage, thus preventing the delivery of mixed water. This is only guaranteed when there is a minimum temperature difference between the inlet hot water and the mixed water delivery of 15°C.

#### Certification

5200 series thermostatic mixing valves are certified by the Buildcert and Kiwa bodies as compliant with the requirements of EN 1111 and EN 1287.

### Operating principle

The thermostatic mixing valve mixes the hot and cold water at the inlet so as to maintain the mixed water constantly at the set temperature at the outlet.

A thermostatic element (1) is fully immersed in the mixed water flow (2). It contracts or expands, moving an obturator (3) which controls the passage of hot (4) or cold (5) water at the inlet. If the inlet temperature or pressure changes, the internal element automatically reacts to restore the set temperature at the outlet.

## Hydraulic characteristics

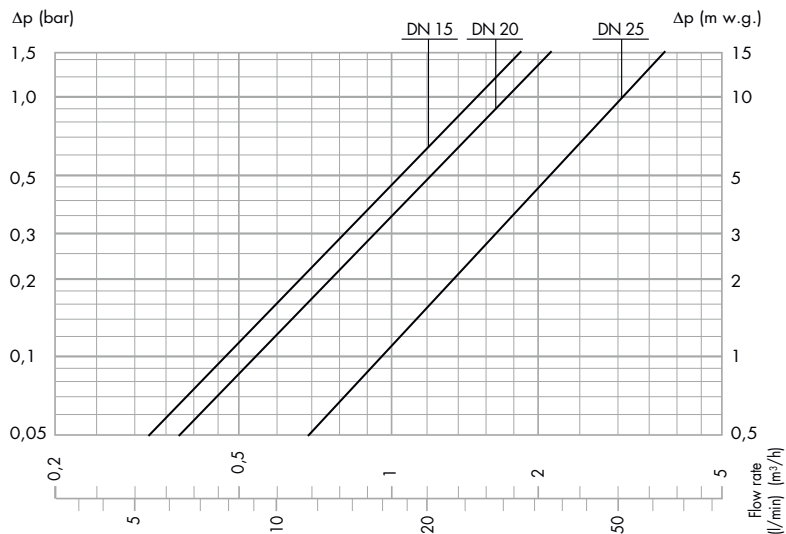

Recommended flow rate values to ensure stable operation with an accuracy of  $\pm 2^\circ\text{C}$

Code	DN	Kv (m³/h)
520040	15	1,5
520050	20	1,7
520060	25	3,0

* $\Delta p = 1,5 \text{ bar}$	Minimum (m³/h)	Maximum* (m³/h)
DN 15	0,24	1,80
DN 20	0,24	2,00
DN 25	0,36	3,60

## Application

Thermostatic mixing valves 5200 series are used for applications at the point of distribution, to control the temperature of the domestic hot water distributed in the network.

To guarantee stable operation, the mixing valve must be supplied with a minimum flow rate of 4 l/min (DN 15 and 20) and 6 l/min (DN 25).

## Selecting the mixing valve size

Given the design flow rate, taking into account simultaneous use of the domestic appliances, the mixing valve size should be selected by checking the head loss on the provided graph. In this case, it is necessary to check the available pressure, the head loss in the system downstream of the mixing valve and the residual pressure to be guaranteed for user appliances.



Sizing software available at [www.caleffi.com](http://www.caleffi.com)  
Apple Store and Google play.

## Installation

Before installing the mixing valve, the connecting pipes should be flushed to remove any impurities that could impair performance. We recommend always installing strainers of sufficient capacity at the inlet from the water main.

5200 series thermostatic mixing valves must be installed according to the diagrams shown in the instruction sheet or in this leaflet.

5200 series thermostatic mixing valves can be installed in any position, horizontally or vertically.

The following are indicated on the body of the mixing valve:

- hot water inlet, indicated by letter H (Hot) and a red mark
- cold water inlet, indicated by letter C (Cold) and a blue mark
- mixed water outlet, indicated by the word "MIX".

## Check valves

In systems with thermostatic mixing valves, check valves must be installed to prevent undesired backflow. 5200 series mixing valves are supplied complete with check valves on the hot and cold water inlets.

## Commissioning

In view of the special applications of the thermostatic mixing valve, it must be commissioned in accordance with current regulations by qualified technicians, using appropriate temperature measurement equipment. We recommend using a digital temperature gauge for measuring the mixed water temperature.

## Temperature adjustment

The temperature is set at the desired value using the control knob with the graduated scale on the valve.

Pos.	Min	1	2	3	4	5	6	7	Max
DN 15÷DN 20 T(°C)	35	40	45	48	52	56	60	63	65
DN 25 T(°C)	35	38	41	45	50	53	56	60	65

con:  $T_{hot} = 70^\circ\text{C}$  ·  $T_{cold} = 15^\circ\text{C}$

$P_{hot} = 3 \text{ bar}$   $P_{cold} = 3 \text{ bar}$

## Locking the setting

Turn the knob onto the required number, unscrew the upper screw, remove the knob and put it back on so that the internal reference couples with the protrusion on the knob holder nut.

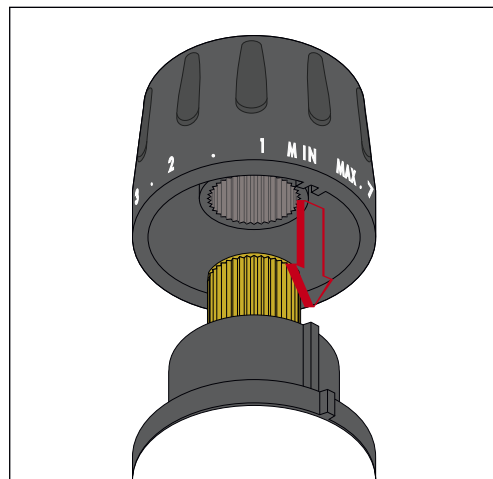

## Application diagrams

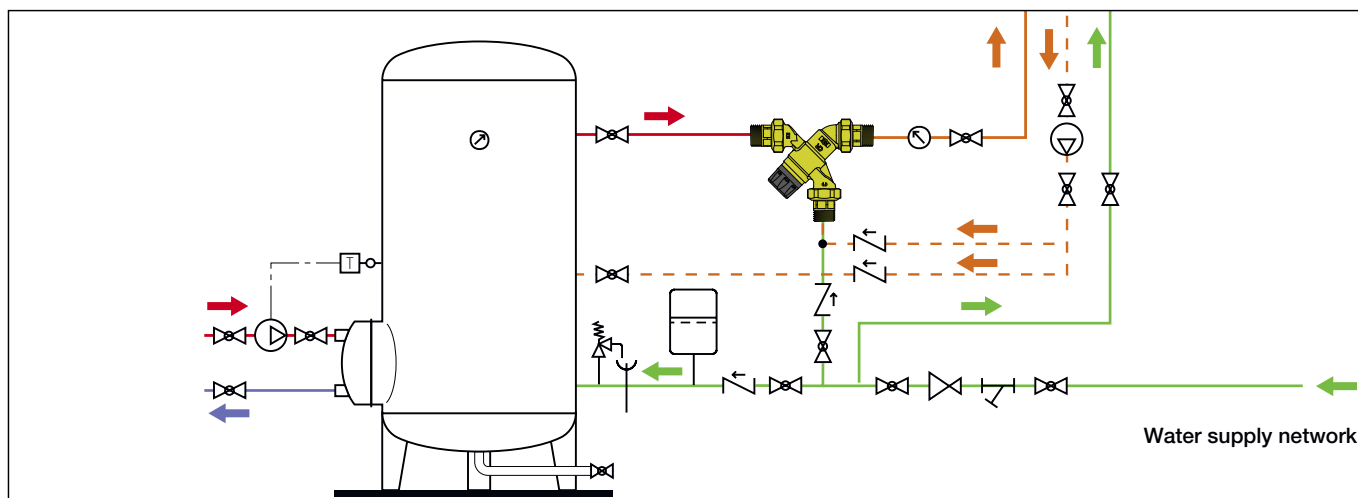
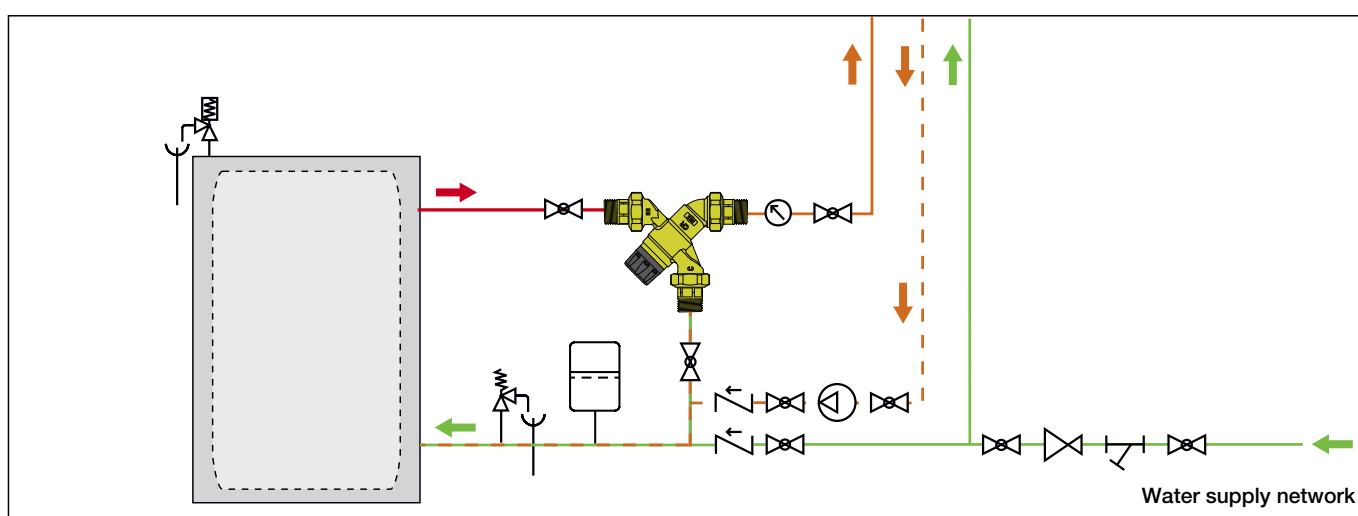
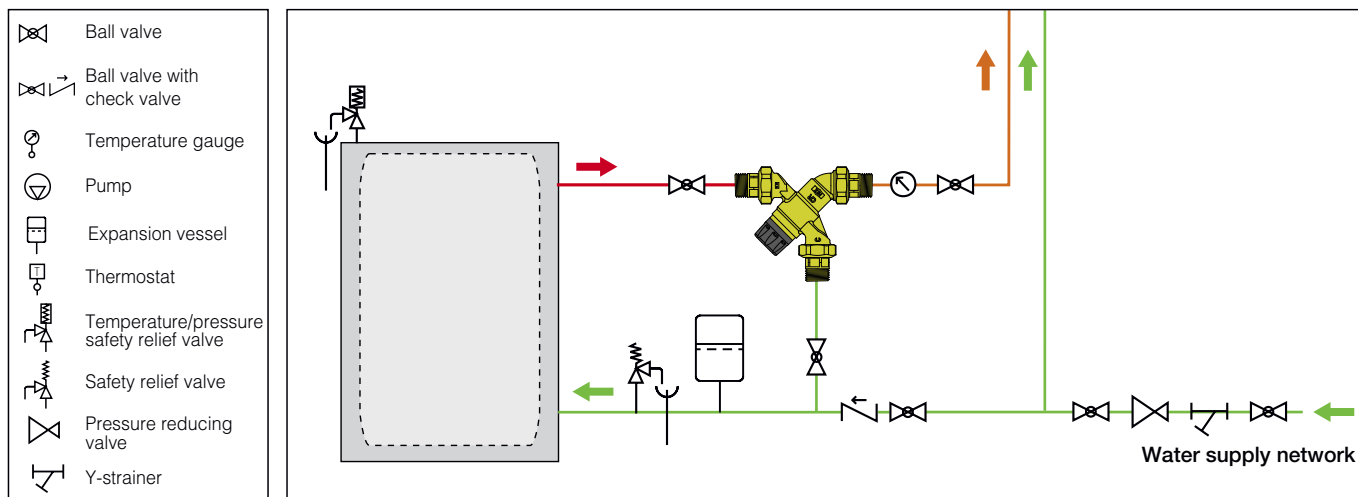

## SPECIFICATION SUMMARY

### 5200 series

"L" pattern adjustable thermostatic mixing valve. Size DN 15 (from DN 15 to DN 25). Connections 1/2" (from 1/2" to 1") (ISO 228-1) with union. Dezincification resistant alloy body. PSU obturator. Stainless steel springs. EPDM seal elements. ABS control knob. Maximum inlet temperature 90°C. Adjustment control range from 35°C to 65°C. Accuracy  $\pm 2^\circ\text{C}$ . Maximum working pressure (static) 10 bar. Maximum working pressure (dynamic) 5 bar. Maximum inlet pressure ratio (H/C or C/H) 2:1. Equipped with tamper-proof temperature setting lock.

*We reserve the right to make changes and improvements to the products and related data in this publication, at any time and without prior notice.*