

Connection and energy management unit, heating and instantaneous domestic hot water version



01229/14 GB

replaces dp 01229/12 GB

2855 series



Function

The connection and energy management unit, preassembled in the box, enables combining solid fuel generators with another type of generator, which may already be present in the heating system.

Main functional features:

- connection of solid fuel generators (**with open or closed vessel**) with other closed vessel generators
- possibility of **not adding the power outputs of the two generators**;
- automatic system management with a specific digital regulator for heating circuits, instantaneous production of domestic hot water and simple thermal solar system
- built-in anti-condensation system (optional) for solid fuel generator
- easy access to components for maintenance
- practical installation thanks to the arrangement in a box.

Reference documentation

- Tech. broch. 01223 Anti-condensation valve 280 series

Product range

Code 2855..WYP	Connection and energy management unit, heating and instantaneous domestic hot water version	size 3/4" M
Code 285550WYP	Connection and energy management unit, heating and instantaneous domestic hot water version without anti-condensation valve	size 3/4" M

Technical specifications

Materials

Connection pipes:	copper EN 12735-1 Cu-DHP
Domestic water pipes:	stainless steel

Anti-condensation valve (optional)

Body:	brass EN 1982 CB753S
Cap:	brass EN 12164 CW614N
Obturator:	PSU
Spring:	stainless steel EN 10270-3 (AISI 302)
Seal:	EPDM
Union seal:	non-asbestos fibre
Thermostatic wax sensor	

Dirt separator

Body:	brass EN 1982 CB753S
Dirt collection chamber:	brass EN 12165 CW617N
Internal element:	stainless steel EN 10088-2 (AISI 304)
Hydraulic seals:	EPDM
Drain valve:	brass EN 12165 CW617N

Heat exchangers

Body:	brazed stainless steel
-------	------------------------

Diverter valve with spring return

Body:	brass EN 12165 CW617N
Obturator stem:	stainless steel EN 10088-3 (AISI 303)
Obturator:	EPDM
Δp max:	1 bar

Shut-off valves

Body:	brass EN 12165 CW617N
Ball:	brass EN 12164 CW614N
Seal elements:	EPDM

Diverter ball valve for DHW priority

Body:	brass EN 12165 CW617N
Ball:	brass EN 12164 CW614N, chrome plated
Ball seal:	PTFE with EPDM O-Ring
Control stem seal:	double EPDM O-Rings
Union seal:	EPDM O-Ring
Δp max:	10 bar

Performance

Medium:	water, glycol solutions
Max. percentage of glycol:	30%
Max. working pressure:	10 bar
Working temperature range:	5–100°C
Anti-condensation setting temperature (Tset):	45°C, 55°C, 60°C, 70°C
Setting accuracy:	$\pm 2^\circ\text{C}$
By-pass complete closing temperature:	$T_{\text{mix}} = T_{\text{set}} + 10^\circ\text{C} = T_r$
Max. heat exchanger net output:	35 kW
Max. recommended primary circuit flow rate:	1,5 m ³ /h
Max. recommended secondary circuit flow rate (system):	1,5 m ³ /h
Max. domestic hot water heat exchanger net output:	35 kW
Max. domestic hot water flow rate delivery:	1,1 m ³ /h
Connections:	3/4" M (ISO 228-1)

Regulator

Electric supply:	230 V - 50 Hz
Power consumption:	5,5 VA
Protection class:	IP 40

Diverter valve actuator with spring return

Synchronous motor	
Normally closed	
Electric supply:	230 V - 50 Hz
Power consumption:	6,5 W; 7 VA
Opening time:	70–75 s
Closing time:	5–7 s
Auxiliary microswitch contact rating:	0,8 A
Protection class:	IP 40
Maximum ambient temperature:	40°C
Complies with Directives:	73/23/EC and 89/336/EC

Diverter ball valve actuator for DHW priority

Synchronous motor	
Electric supply:	230 V ($\pm 10\%$) - 50–60 Hz
Power consumption:	8 VA
Auxiliary microswitch contact rating:	0,8 A (230 V)
Protection class:	IP 44 (vertical control stem)
Operating time (angle of rotation 90°):	10 s
Ambient temperature range:	0–55°C
Dynamic torque:	8 N·m

Flow switch with magnetically operated contacts

Body: brass EN 12165 CW617N

Performance

Max. working pressure: 6 bar
 Voltage: 230 V (ac)
 Maximum current intensity: 0,02 A
 Normally open (NO) contacts
 Contacts close with increasing flow at: 156 l/h
 Contacts open with decreasing flow at: 108 l/h
 Protection class: IP 65

Temperature probes for solid fuel generator and instantaneous domestic hot water (provided) and solar thermal circuit (optional)

NTC type with two-wire cable
 Working temperature range: -20-100°C

Temperature probe for solar thermal circuit (optional)

Pt1000 type 3 m SIHF cable, 2x0,5 mm² Tmax 180°C

Pump

High-efficiency pump:
 - primary side, solid fuel generator: model YONOS PARA 25/6
 - secondary side, system: model YONOS PARA 15/6

Material

Body: cast iron GG 15/20
 Electric supply: 230 V - 50 Hz
 Max. ambient humidity: 95%
 Max. ambient temperature: 80°C
 Protection class: IP 44
 Pump centre distance: 130 mm
 Pump connections:
 - primary side, solid fuel generator: 1 1/2" with nut
 - secondary side, system: 1" with nut

Heat exchanger insulation

Material: closed cell expanded PE-X
 Thickness: 20 mm
 Density:
 - inner part 30 kg/m³
 - outer part 50 kg/m³
 Thermal conductivity (DIN 52612):
 - at 0°C 0,038 W/(m·K)
 - at 40°C 0,045 W/(m·K)

Coefficient of resistance to diffusion of water vapour (DIN 52615): > 1300
 Temperature range: 0-100°C
 Reaction to fire (DIN 4102): class B2

Head available at unit connections

Primary side YONOS PARA 25/6 pump

Solid fuel generator flow/return connections

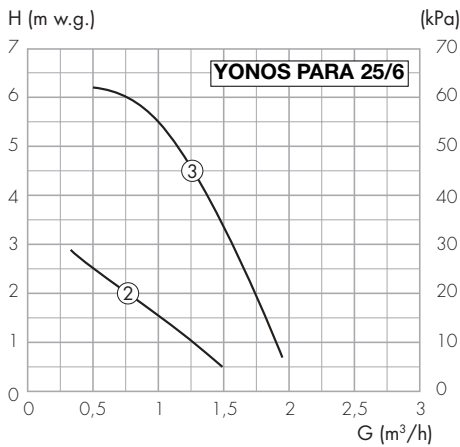

Secondary side YONOS PARA 15/6 pump

Heating system flow/return connections

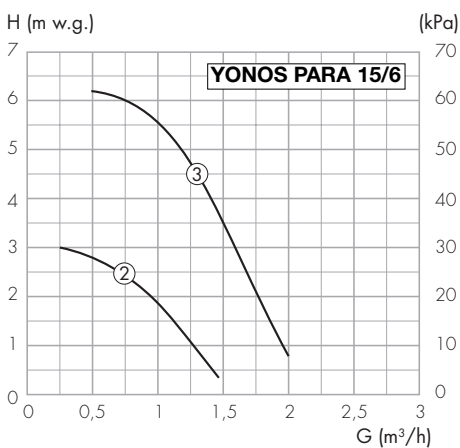

Instantaneous DHW production

Generator power output (kW)	Primary side flow temperature (°C)	DHW secondary outlet temperature (°C)	DHW secondary flow rate	
			m³/h	l/min
35	75	45	0,9	15
30	75	45	0,8	13,3
25	75	45	0,65	10,8
20	75	45	0,5	8,3
15	75	45	0,4	6,7
10	75	45	0,25	4,2

Reference conditions:
 DHW inlet temperature: 12°C
 Diagram valid for units equipped with anti-condensation valve set at 45°C and 55°C.

Dimensions

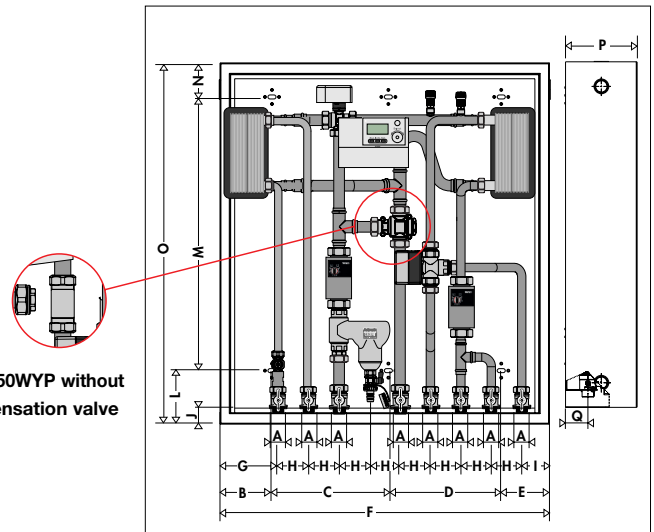

Code 285550WYP without anti-condensation valve

Code	A	B	C	D	E	F	G	H
28555.WYP	3/4"	125	320	320	125	890	165	80
I	J	L	M	N	O	P	Q	Mass (kg)
85	38	116,5	700	77	895	160	50	41

Connecting circuit between integration gas boiler and heating system (diverter valve + pipes): Kv (m³/h) = 4,5
 DHW circuit (heat exchanger + pipes) Kv (m³/h) = 1

Code completion

Setting	45°C	55°C	60°C	70°C
•	4	5	6	7

• = 0 Without anti-condensation valve

Note:

The YONOS PARA pump can operate with proportional pressure control, which adapts the performance to the system requirements. For further details, see the installation instruction sheet of the pump supplied in the package.

Wooden biomass and condensation build-up

Wooden solid fuel contains a variable moisture percentage depending on the type (logs, pellets, woodchips etc.) and seasoning. Water vapour is released during the solid fuel drying phase inside the combustion chamber. The presence of cold zones in the generator or flue gas chimney can lower the temperature of the flue gas down to the dew point, causing condensation to occur. Water vapour condenses on the generator surfaces, together with soot and part of the unburned hydrocarbons contained in the flue gas, producing deposits and tar. These substances stick to the walls of the generator, covering most of the inner surfaces. In addition to being dangerous due to its flammability, tar is damaging to the integrity of the generator and limits the efficiency of the flue gas-system water exchanger.

By keeping the generator walls at the highest possible temperature, the anti-condensation valve (optional) incorporated into the unit limits the formation of these substances, thereby increasing the combustion efficiency, controlling the emissions into the environment and prolonging the generator life.

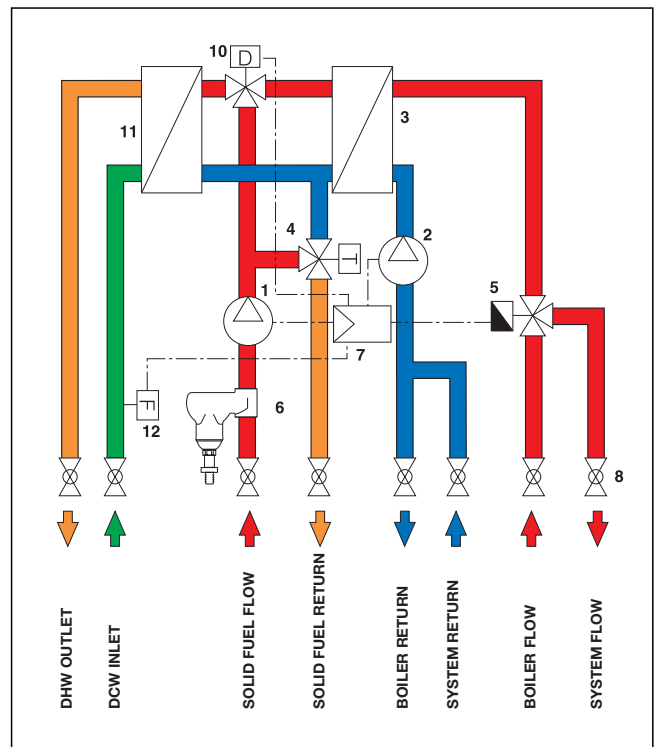
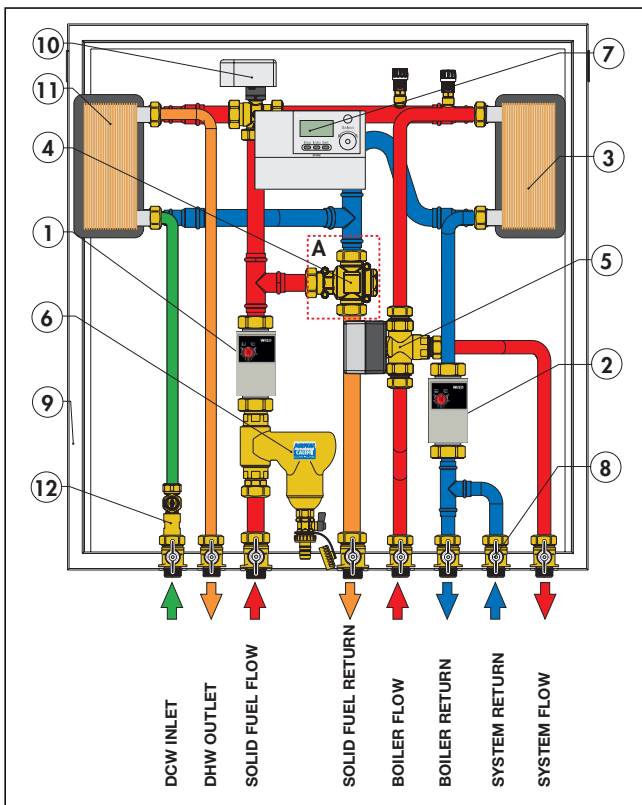
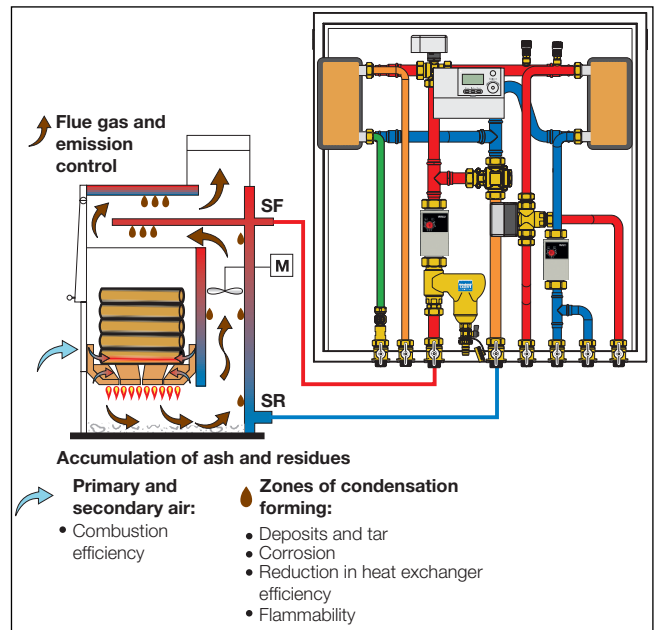

Characteristic components

- 1) Wilo YONOS PARA 25/6 pump on primary side solid fuel generator
- 2) Wilo YONOS PARA 15/6 pump on secondary side (system)
- 3) Brazed plate heat exchanger for heating
- 4) Anti-condensation valve (optional)
- 5) Three-way diverter valve with spring return
- 6) Dirt separator
- 7) Digital regulator
- 8) Shut-off ball valves
- 9) Box for exposed installation
- 10) Three-way three point diverter ball valve for DHW priority
- 11) Brazed plate heat exchanger for DHW
- 12) Flow switch

Code 28550WYP without anti-condensation valve

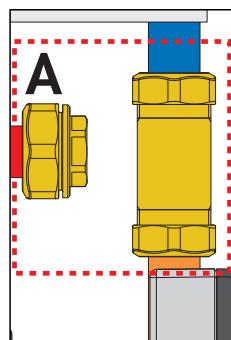

A) Code 28550WYP without anti-condensation valve

- Pump
- Brazed plate heat exchanger
- Three-way diverter valve with spring return
- Three-way three point diverter ball valve for DHW priority
- Anti-condensation valve (optional)
- Dirt separator
- Digital regulator
- Shut-off valve
- Flow switch

Operating conditions

The digital regulator automatically manages the unit's operation, receiving the signal from the probes and activating the pumps, the motorized valves and the generators. The heating circuit and the instantaneous preparation of domestic hot water are managed according to needs.

The room thermostat RT provides the regulator with information regarding the room temperature. When the room calls for thermal energy, the regulator activates either the solid fuel generator, with priority by checking the temperature with the probe S1 and operating the contact K, or alternatively activates the integration boiler by means of the contact C. The connection of the solid fuel generator with the secondary system is made via the plate heat exchanger, through the operation of the three-way motorized diverter valve with spring return V1 and the activation of the circulation pumps P1 and P2 (fig. 1). The connection of the integration boiler to the secondary system is performed by operating the motorized three-way valve V1 and simultaneously switching off the circulation pumps P1 and P2. In this situation, the secondary system receives energy directly from the integration boiler (fig. 2).

The flow switch indicates the opening of a domestic water tap. If the solid fuel generator is able to supply energy, the regulator diverts the domestic water priority ball valve V3 so as to supply water from the primary heating circuit to the primary side of the DHW heat exchanger, thereby producing domestic hot water instantaneously (fig. 3). If the generator is switched off or not yet at temperature, the SOLARINICAL kit (optional) is used to integrate into the boiler the domestic cold water entering the kit thus producing domestic hot water through the instantaneous gas boiler (fig. 4).

Heating with solid fuel generator

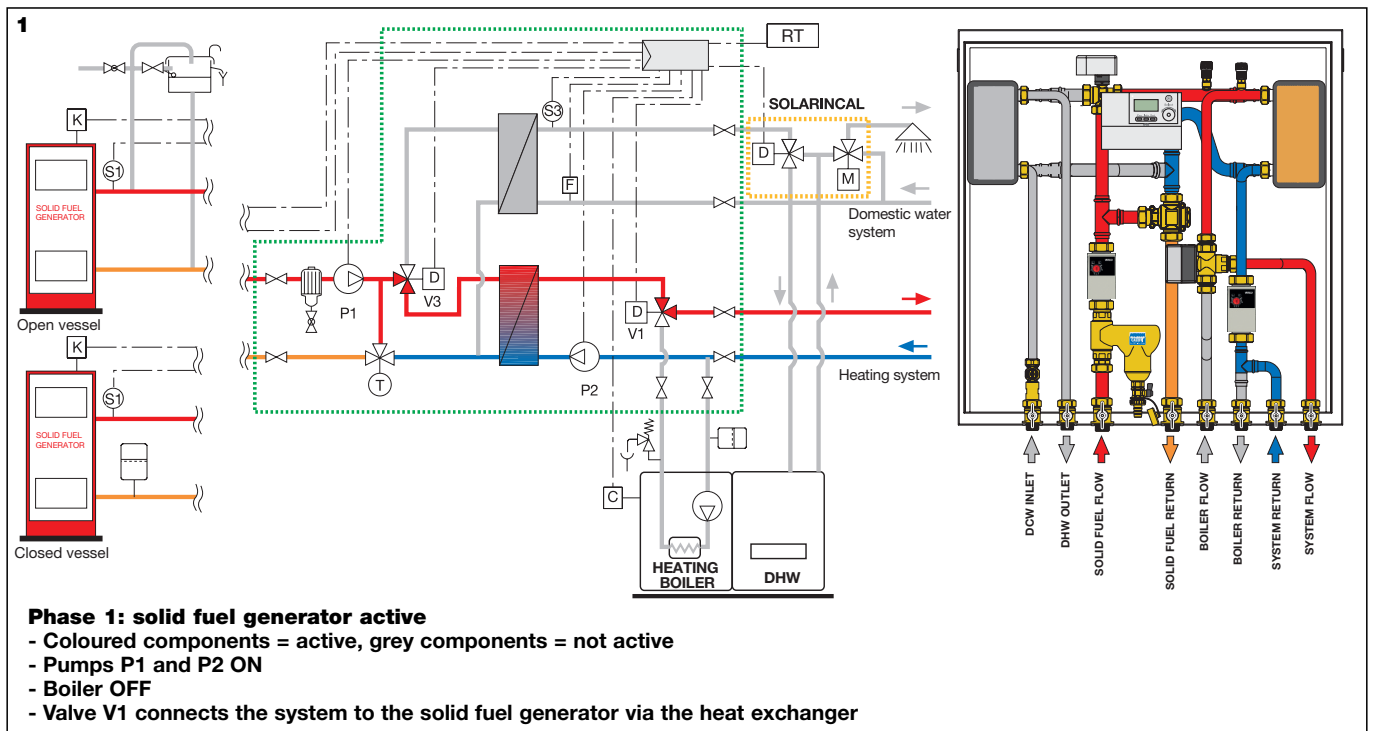

Heating with boiler

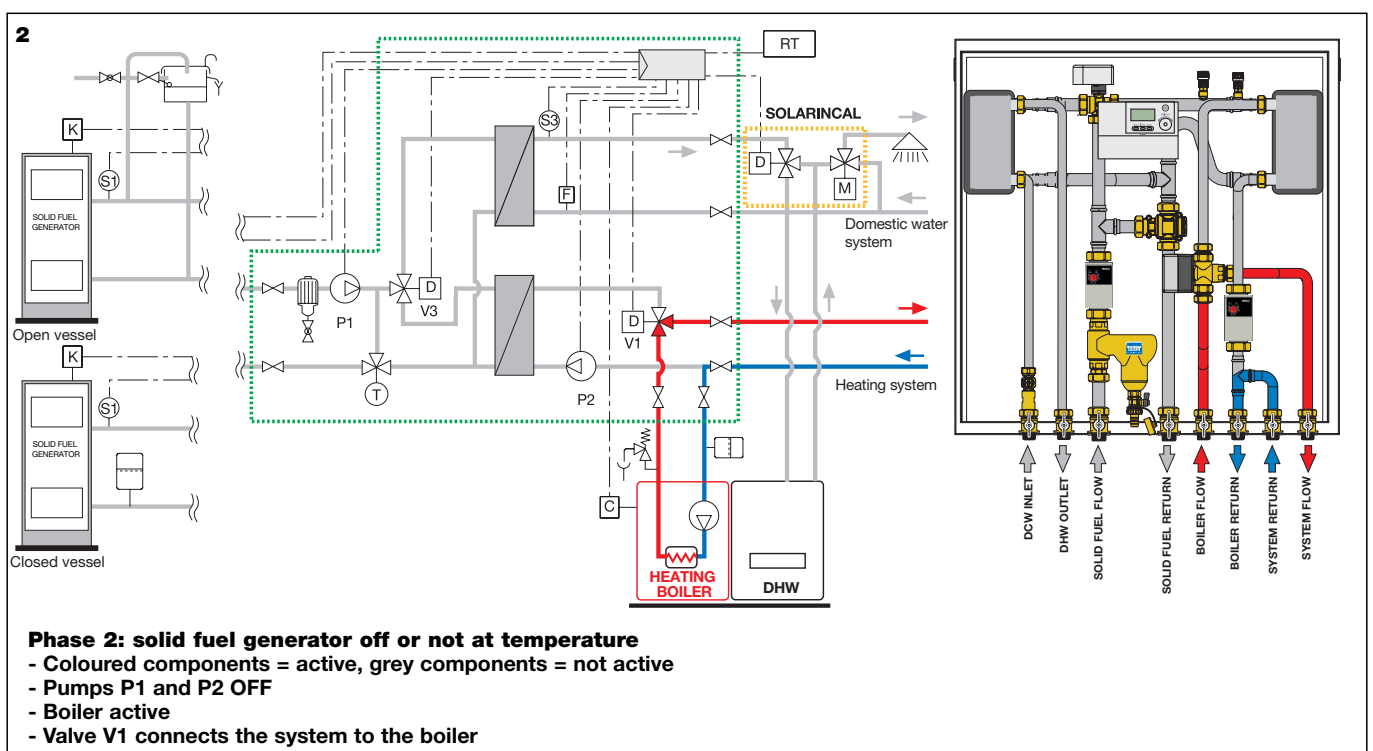

Domestic hot water production with solid fuel generator

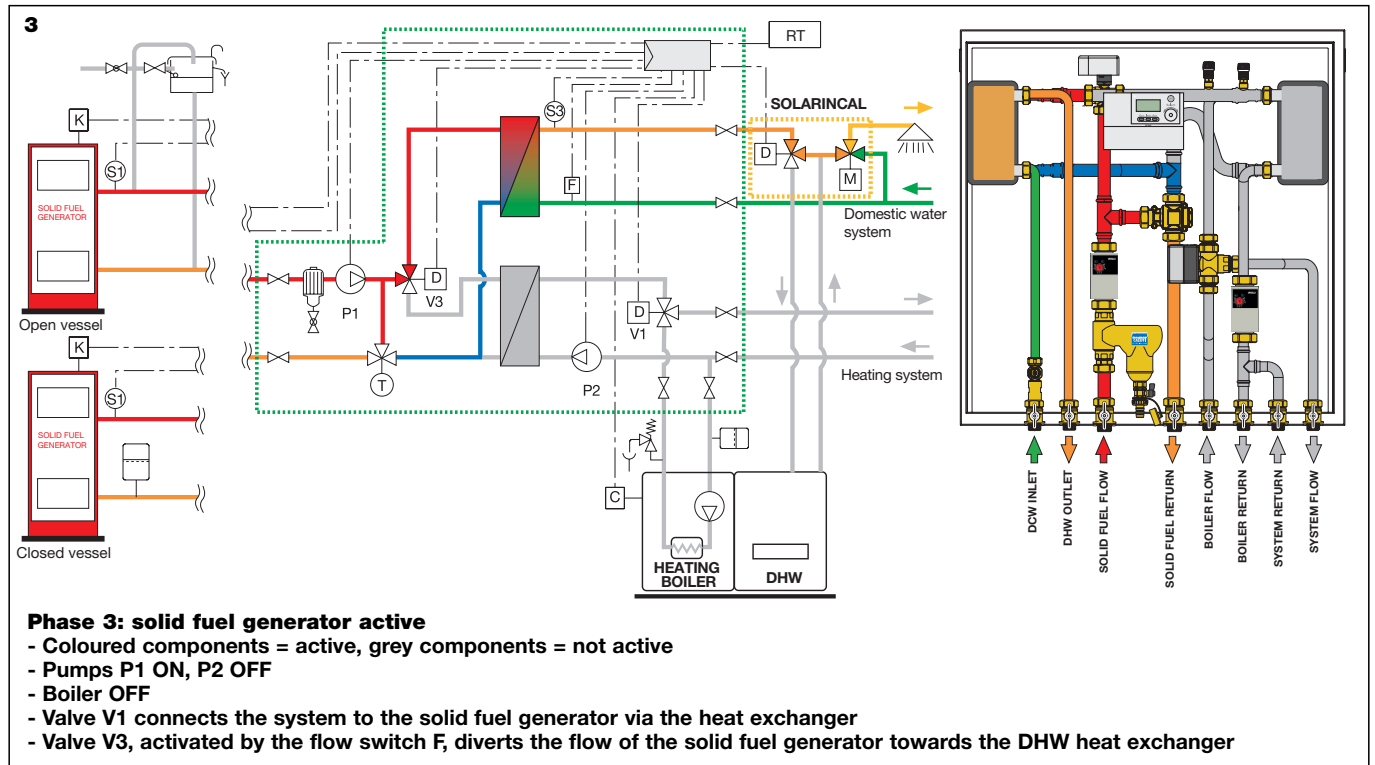

Domestic hot water production with boiler

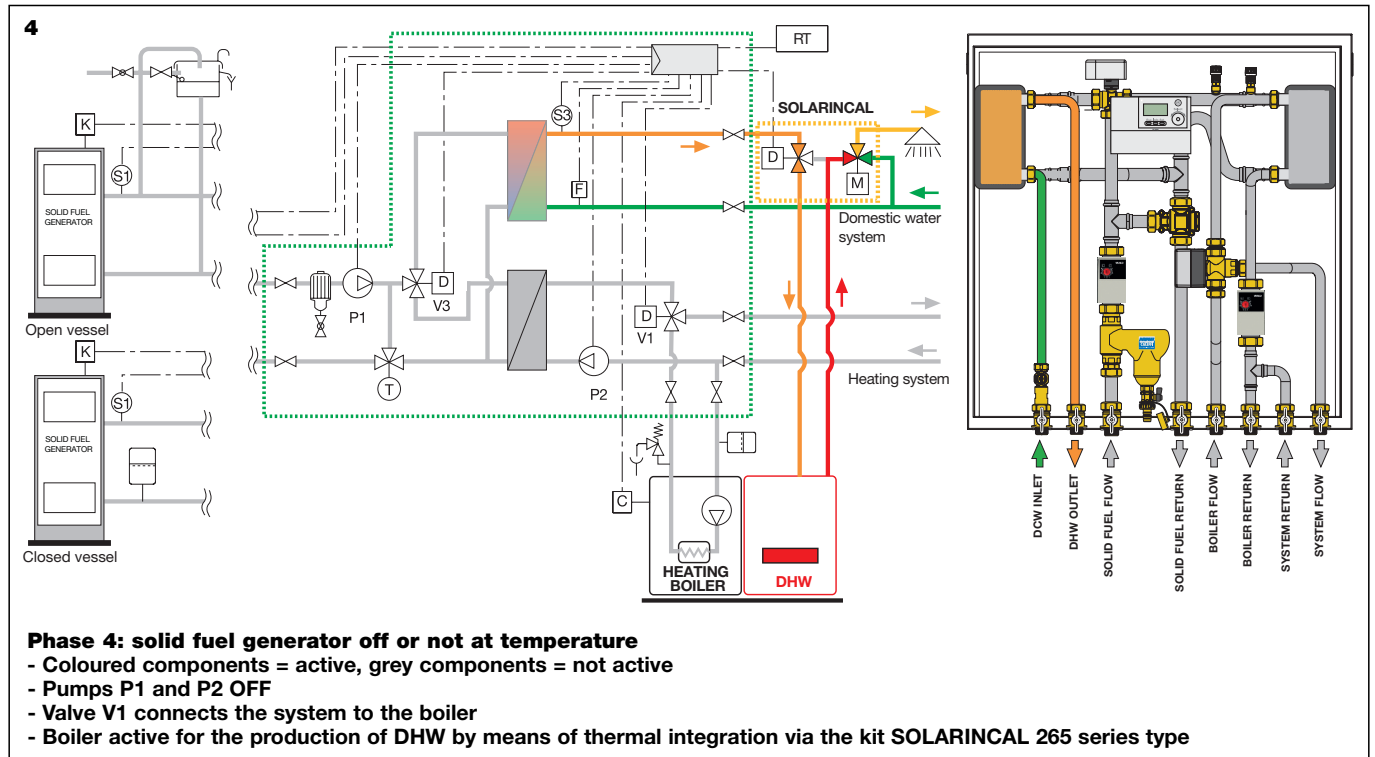

Construction details

Anti-condensation valve (optional)

The device incorporates a thermostatic sensor to control the temperature of water returning to the solid fuel generator so as to prevent condensation. The sensor has been specifically realised to be removed from the valve body for maintenance or replacement if necessary.

Maintenance and setting modification

The adjustment sensor of the anti-condensation valve (optional) can easily be removed for maintenance or setting change, according to the following procedure:

- close the shut-off valves of the primary circuit to isolate the anti-condensation valve from the system;
- remove the anti-condensation valve from the unit;
- unscrew the cap of the anti-condensation valve;
- take out the unit consisting of the spring, obturator and thermostatic sensor, noting the position of each component;
- perform maintenance or replace the sensor with a spare part, fitting it in the same position;
- re-fit the unit consisting of the spring, obturator and thermostatic sensor inside the valve body, positioned vertically;
- screw the cap back onto the valve body;
- re-fit the anti-condensation valve onto the unit with the port marked by the flame symbol  pointing the solid fuel generator;
- if the thermostat is replaced with a spare part featuring a different setting, apply the label indicating the new setting to the cap, label supplied in the spare part packaging.

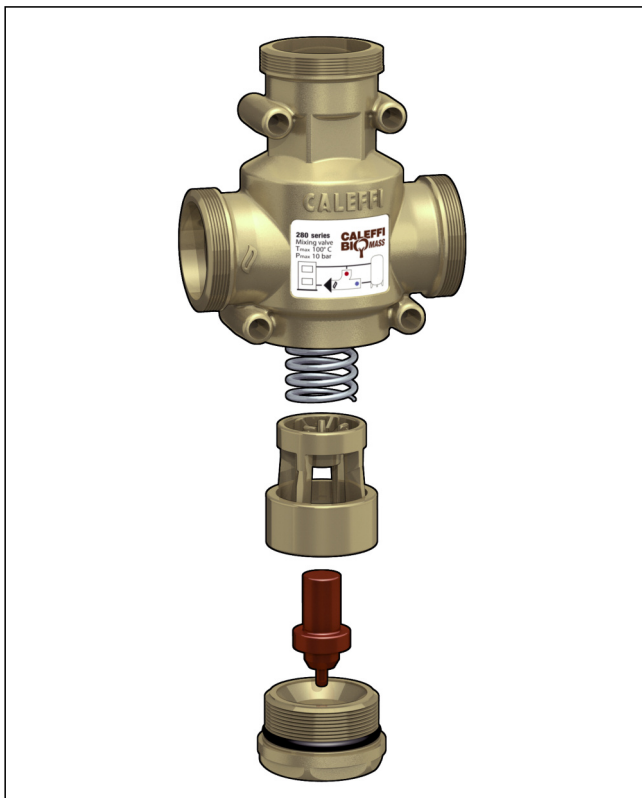

Heat exchanger

The presence of the heat exchanger allows the connection of an open or closed vessel solid fuel generator (or other type of generator) to a system, new or already in place, equipped with another type of closed vessel generator. The heat exchanger represents a hydraulic break, in other words a physical separation between the two circuits, therefore the power outputs of the two generators are not added together, as indicated by INAIL (Italy).

The heat exchanger also helps to protect the integrity of the solid fuel generator, since it physically separates the two circuits and prevents impurities in the existing circuit from clogging the solid fuel generator.

Three-way diverter valve with spring return

The three-way diverter valve provides a further mechanical separation between the primary circuit and the secondary circuit.

In the event of an electric supply failure, the valve positions itself mechanically in diversion towards the generator of the secondary side, thereby guaranteeing that only one of the two generators actually remains connected to the system. The valve also enables correct circulation of the medium, without any need to install check valves.

Dirt separator

To allow continuous removal of dirt from the primary circuit connected to the solid fuel generator, the unit is equipped as standard with a DIRTCAL® vertical dirt separator.

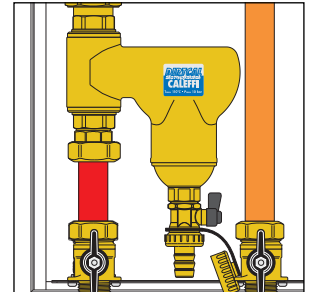

Installation

The connection and energy management unit is supplied preassembled in a box for wall installation. The unit can be installed only in vertical position, with all the threaded connections pointing downwards.

It is recommended to clean accurately the existing system, so as to minimize clogging problems at the heat exchanger. For this purpose, it is advisable to install strainers of suitable capacity in the existing secondary system as well, to ensure a continuous cleaning action.

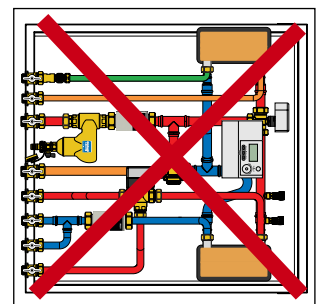
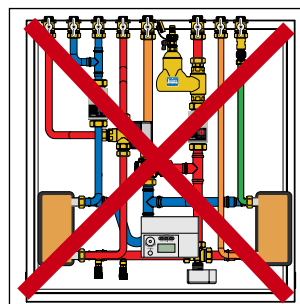
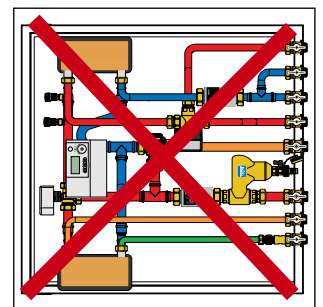
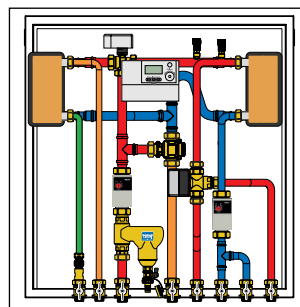

Production of domestic hot water

The 2855 series unit allows instantaneous production of domestic hot water. The circuit fitted for this function is complete with a stainless steel plate heat exchanger, a priority diverter ball valve with 10-second rotation, a flow switch and stainless steel pipes.

The regulator allows the control of a further motorized external kit (optional) SOLARINCAL, code 265359, for the integration into the boiler of the DHW produced by the unit.

The regulator utilizes the thermal energy arriving from the solid fuel generator to produce domestic hot water instantaneously and, in the event that the temperature at the heat exchanger outlet is not high enough to provide sufficiently hot water at the point of use, operates the diverter valve incorporated into the SOLARINCAL kit (optional), code 265359, to integrate it into the boiler. The boiler can be equipped with a built-in DHW storage or can be a modulating instantaneous type (see tech. broch. 01163).

SOLARINCAL 265 series

Characteristic components of code 265359

- 1) Diverter valve
- 2) Diverter valve actuator
- 3) Thermostatic mixing valve

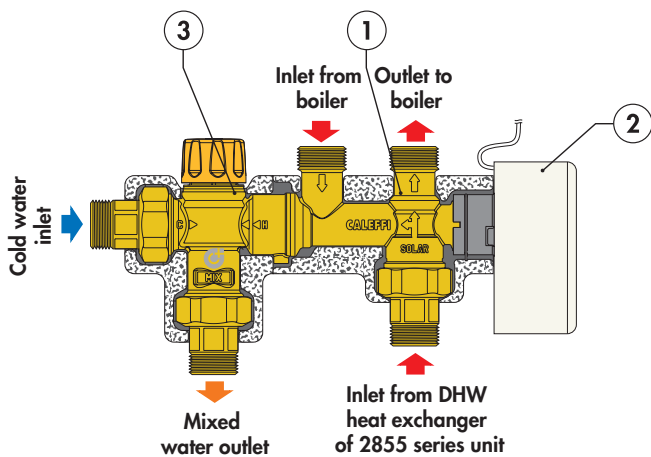

Operating principle

The regulator of the 2855 unit operates the diverter valve, installed at the inlet of the kit, in response to the signal from the probe S3 installed at the outlet of the DHW instantaneous heat exchanger. Depending on the temperature set inside the regulator (factory setting 40°C), the valve diverts the water towards the user circuit or activates the boiler circuit, **with thermal integration**.

A thermostatic anti-scald mixing valve, at the kit outlet, constantly controls the temperature of the water sent to the user.

Hydraulic diagram

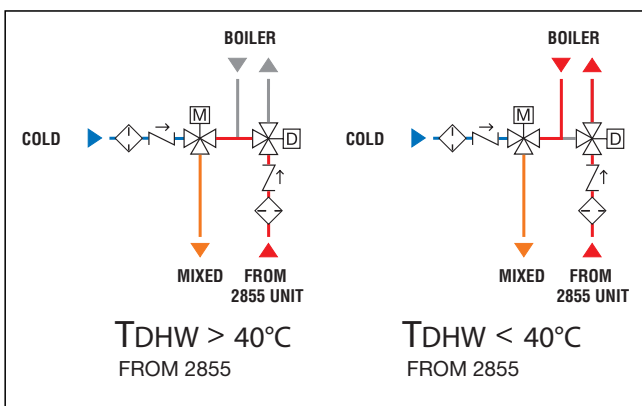

Construction details

Mixing valve

High resistance to temperature

Internal control components are designed to maintain constant the mixing valve performance with inlet hot water temperatures up to 100°C, in continuous operation.

Anti-scale materials

The materials used in constructing the mixing valve were selected to eliminate seizing due to limescale deposits. All functional parts have been made using a special anti-scale material with low friction coefficient, which ensures over time performance.

Anti-scald safety function

As a safety measure, in case of failure of the cold water supply at the inlet, the valve immediately shuts off the flow of the hot water. This prevents dangerous burns. This performance is guaranteed if there is a minimum temperature difference between the inlet hot water and the outlet mixed water of 10°C. Also in case of failure of the hot water supply, the valve shuts off the cold water port and thus the outlet mixed water to prevent dangerous thermal shocks.

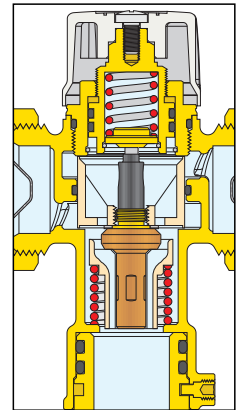

Thermal transients

During transient, following rapid changes in pressure, temperature or flow rate, the outlet mixed water temperature increases with respect to the initial set point and this increase must be of limited duration to guarantee safety.

The anti-scald mixing valve always ensures that these conditions are respected.

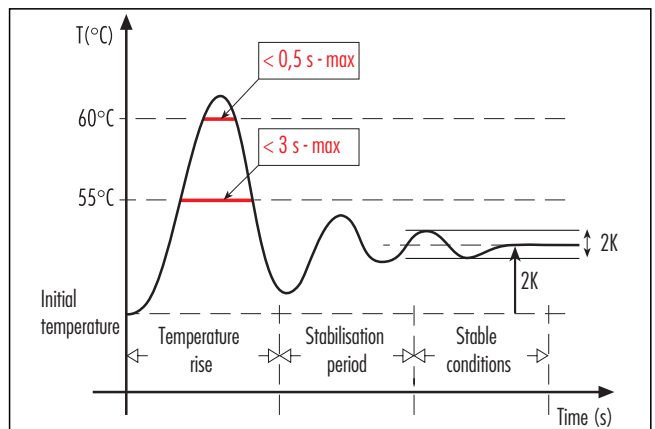

Digital regulator

The digital regulator automatically manages the unit's operation, receiving the signal from the probes and activating the pumps, the motorized valves and the generators, according to the heating and domestic water system needs.

The regulator has a display for the activation of preset programs and for viewing and setting control parameters, such as cut-in temperatures, delay times for the activation of functions, etc.

In addition to programs controlling the operation of the heating and instantaneous domestic hot water system, the device also activates automatic monitoring and safety functions to protect the system, including antiblock for the pumps and diverter valve, anti-freeze, overtemperature control for the solid fuel generator etc.

Description of controls

1. Operating status indicator LED.
2. Mini DIN connector on front of panel for PC connection.
3. Display: visualisation of menu.
4. Select knob: selection of menu, functions and parameter changes.
5. Function buttons.

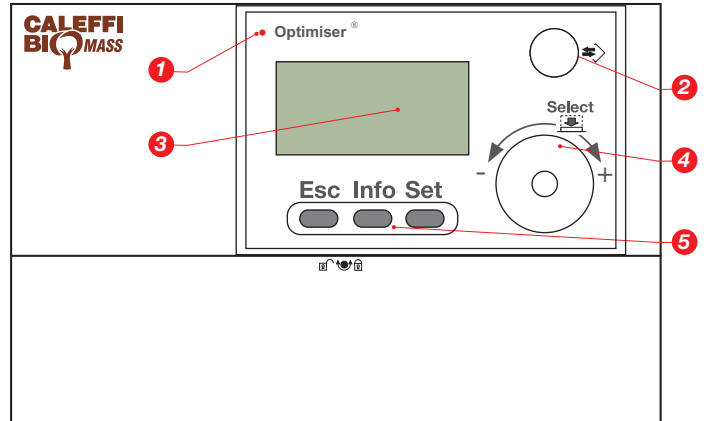

Optional programs

Besides the functionality of the heating and instantaneous domestic hot water system, the regulator menu includes a specific section to manage independently the following circuits:

- **storage in parallel on the heating circuit** (diagram P): the storage is loaded by the surplus energy provided by the solid fuel generator. The storage functions as a reserve of energy to be utilized in response to the next call for heat from the user circuit.
- **simple solar thermal circuit** (diagram A) composed of solar collector and domestic hot water storage: the regulator activates the circulation pump of the solar unit by checking the temperature differential between the top of the solar panels and the bottom part of the storage;
- **loading of two storages** (diagram B): when reaching the temperature differential between the two storages, the regulator activates the pump to transfer energy from the priority storage 1 to the secondary storage 2.

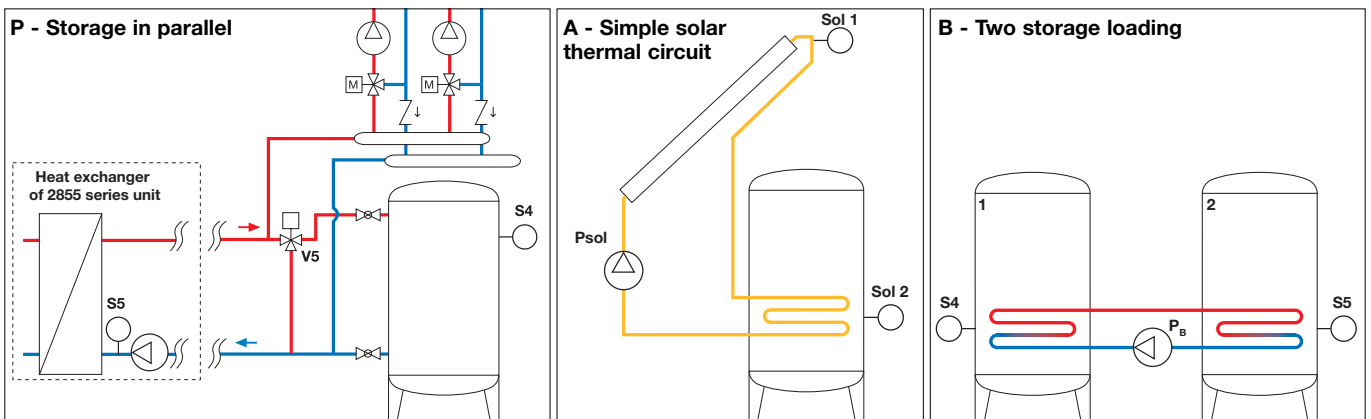

If there are no special needs, the factory-set parameters of the regulator ensure optimum operation of the system without further changes.

For operating details of the various programs, see instruction sheets 28169 and 28180.

Electric connections

The 2855 series unit is provided internally pre-wired. The cables emerging from the unit should be connected by the installer as follows:

- 1) contact **K** for the activation of the solid fuel generator (check the presence of regulator/contact on board the generator);
- 2) probe **S1** to be applied on the solid fuel generator flow pipe;
- 3) contact **C** for the activation of the integration gas boiler;
- 4) contact for room thermostat **RT**;
- 5) electric supply **230 V**;
- 6) contacts for the diverter valve actuator of the optional SOLARINICAL 265 series kit.

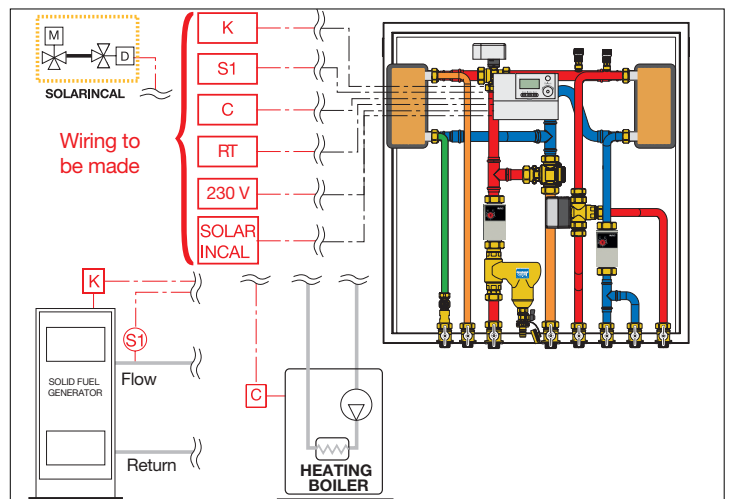

Application diagram

Solid fuel generator combined with auxiliary boiler for direct heating

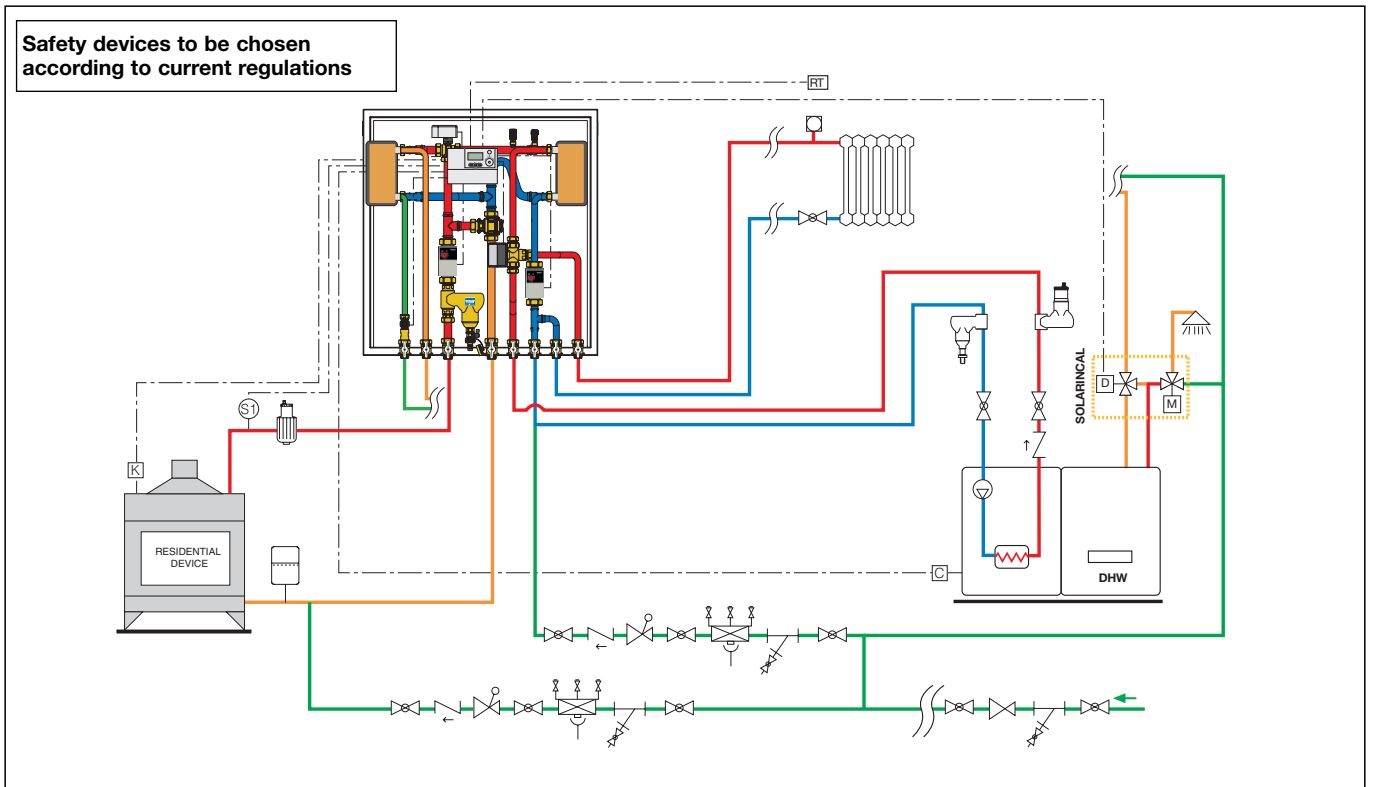

Solid fuel generator, combined with auxiliary boiler for direct heating by way of hydraulic separator

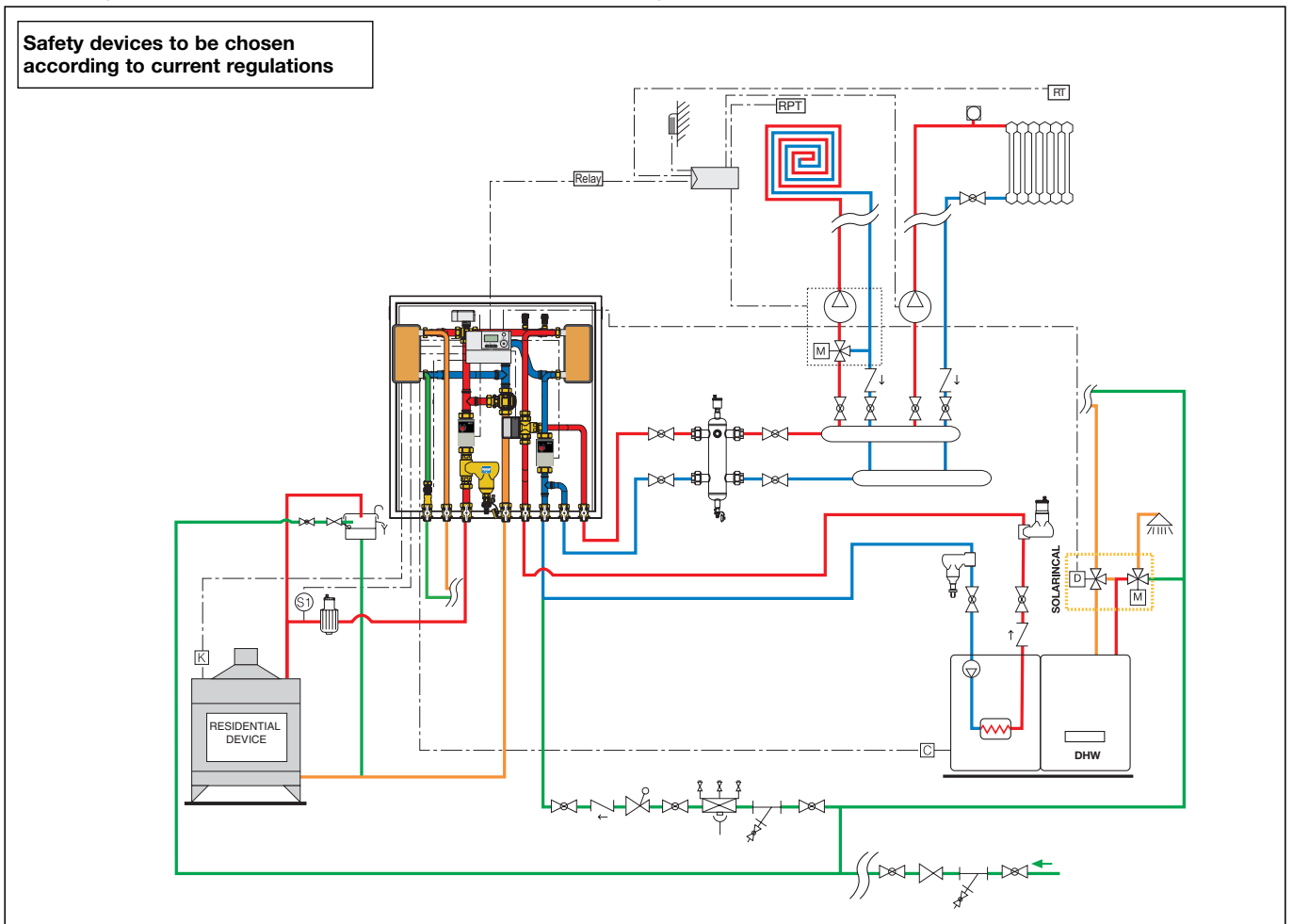

Solid fuel generator, combined with auxiliary boiler for heating with water storage in parallel

Safety devices to be chosen according to current regulations

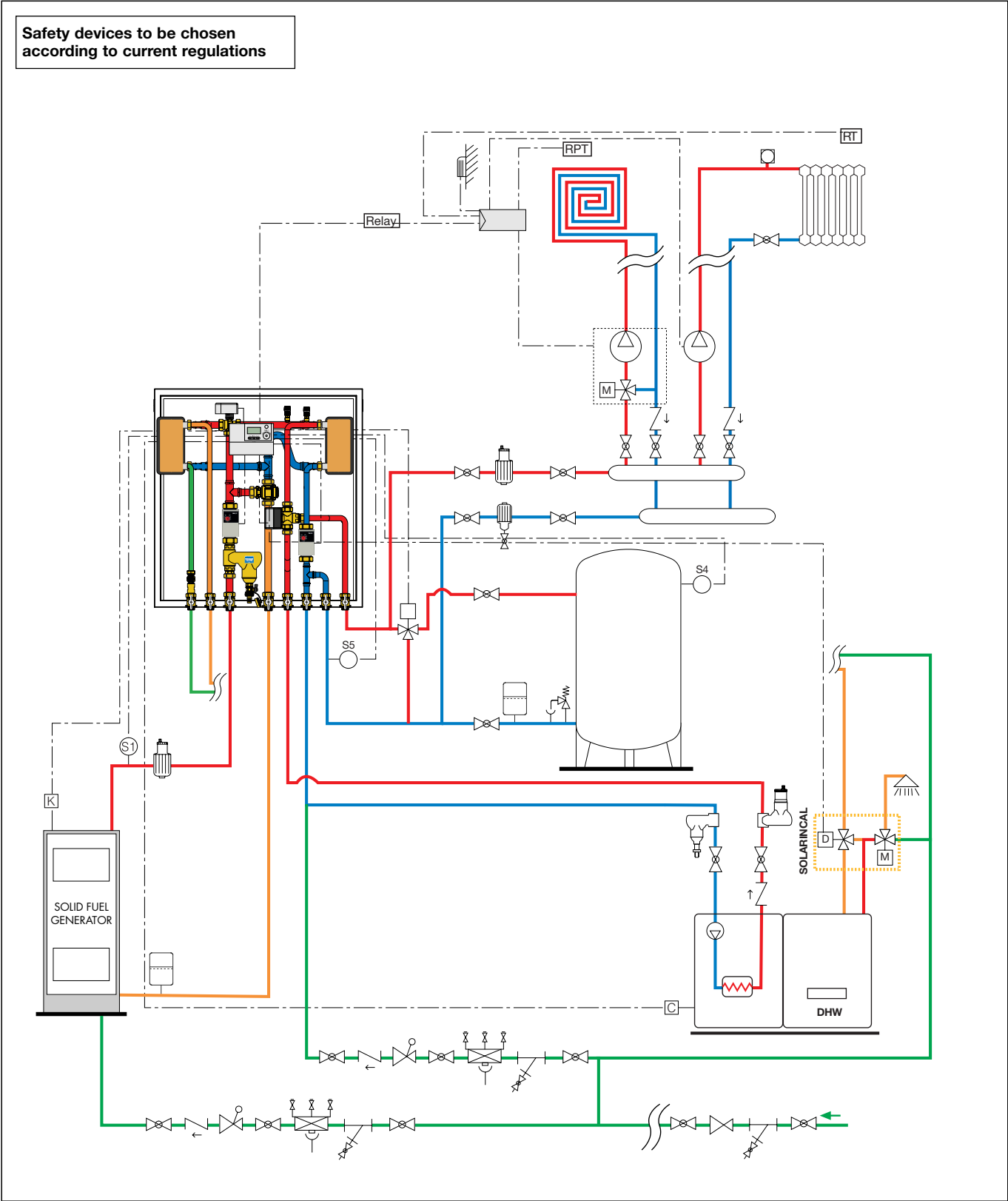

Solid fuel generator, combined with auxiliary boiler for heating and DHW production with direct tank-in-tank storage integrated to a simple solar thermal system

Safety devices to be chosen according to current regulations

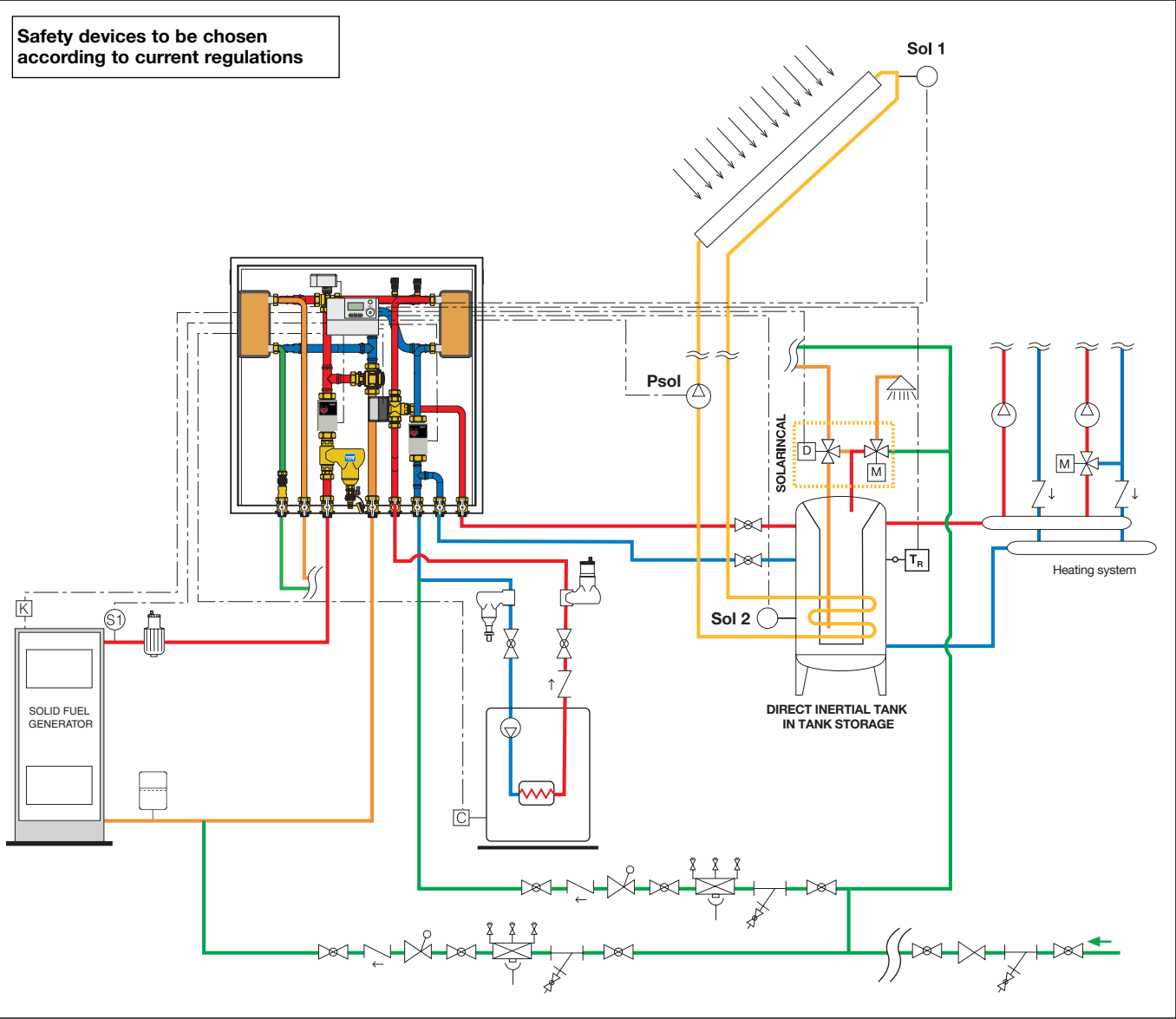

	Deaerator		Motorised mixing valve		Dirt separator for vertical pipes
	Dirt separator		Pressure reducing valve		Deaerator for vertical pipes
	Pump		Regulator		Hydraulic separator
	Shut-off valve		Filling unit		Y-strainer
	Expansion vessel		Backflow preventer		Room thermostat
	Check valve		Safety relief valve		Room probe thermostat
	Outside probe		Thermostatic valve		Adjustable thermostat

SPECIFICATION SUMMARY

2855 series

Connection and energy management unit, heating and instantaneous domestic hot water version. Connections 3/4" M (ISO 228-1). Copper connection pipes. Stainless steel domestic hot water pipes. Medium water and glycol solutions. Maximum percentage of glycol 30%. Maximum working pressure 10 bar. Working temperature range 5–100°C. Complete with: anti-condensation valve (optional) with brass body, brass cap, PSU obturator, stainless steel spring, EPDM seal, anti-condensation temperature setting 45°C, 55°C, 60°C, 70°C, setting accuracy $\pm 2^\circ\text{C}$, by-pass complete closing temperature $T_{set} + 10^\circ\text{C}$; brazed plate heat exchanger with stainless steel body, complete with insulation, maximum net output 35 kW, maximum recommended primary circuit flow rate 1,5 m³/h, maximum recommended secondary circuit (system) flow rate 1,5 m³/h; manual air vents with brass body, POM knob, colour white RAL 9010, PTFE external seals, POM/EPDM internal seals; dirt separator with brass body, brass dirt collection chamber, stainless steel internal element, EPDM hydraulic seals, brass drain valve; shut-off valves with brass body and ball, EPDM sealing elements; diverter valve with spring return, brass body, stainless steel obturator stem, EPDM obturator, actuator with synchronous motor, normally closed, electric supply 230 V - 50 Hz, opening time 70–75 s, closing time 5–7 s, protection class IP 40, maximum ambient temperature 40°C, compliance with Directives 73/23/EC and 89/336/EC; flow switch with magnetically operated contacts, brass body, voltage 230 V (ac), maximum current intensity 0,02 A, contacts normally open, contacts close with increasing flow at 156 l/h, contacts open with decreasing flow at 108 l/h, maximum working pressure 6 bar, protection class IP 65. Motorized three-way ball diverter valve with three-contact actuator for domestic hot water priority. Brass body. Chrome plated brass ball. PTFE ball seal with EPDM O-Ring. Control stem seal with double EPDM O-Ring. Union seals with EPDM O-Ring. Maximum working differential pressure 10 bar. Self-extinguishing polycarbonate actuator. Colour grey RAL 9002. Three-contact synchronous motor with auxiliary microswitch. Electric supply 230 V (or 24 V $\pm 10\%$) -50–60 Hz. Power consumption 8 VA. Dynamic torque 8 N·m. Auxiliary microswitch contact rating 0,8 A. Protection class IP 44 with control stem in vertical position. Operating time (angle of rotation 90°) 10 s. Ambient temperature range 0–55°C. Digital regulator complete with temperature probe for solid fuel generator, electric supply 230 V - 50 Hz, protection class IP 40; high-efficiency pumps, model YONOS PARA 25/6 (primary side, solid fuel generator) and model YONOS PARA 15/6 (secondary side, system) with cast iron body, electric supply 230 V - 50 Hz, maximum ambient humidity 95%, maximum ambient temperature 80°C, protection class IPX4D. NTC type temperature probe for solid fuel generator and instantaneous domestic hot water; NTC and Pt1000 optional probe for simple solar thermal circuit. Provided preassembled in painted sheet metal box for wall installation. Closure with a push-fit clamp.

We reserve the right to change our products and their relevant technical data, contained in this publication, at any time and without prior notice.