

Connection and energy management unit, heating version

2851 series



01227/14 GB
replaces dp 01227/11 GB



Function

The connection and energy management unit, preassembled in the box, enables combining solid fuel generators with another type of generator, which may already be present in the heating system.

Main functional features:

- connection of solid fuel generators **(with open or closed vessel)** with other closed vessel generators
- possibility of **not adding the power outputs of the two generators**
- automatic system management with a specific digital regulator for heating circuits and simple solar thermal system
- built-in anti-condensation system (optional) for solid fuel generator
- easy access to components for maintenance
- practical installation thanks to the arrangement in a box.

Reference documentation

- Tech. broch. 01223 Anti-condensation valve 280 series

Product range

Code 2851..WYP Connection and energy management unit, heating version _____ size 3/4" M
Code 285150WYP Connection and energy management unit, heating version without anti-condensation valve _____ size 3/4" M

Technical specifications

Materials

Connection pipes: copper EN 12735-1 Cu-DHP

Anti-condensation valve (optional)

Body: brass EN 1982 CB753S
Cap: brass EN 12164 CW614N
Obturator: PSU
Spring: stainless steel EN 10270-3 (AISI 302)
Seal: EPDM
Union seal: non-asbestos fibre
Thermostatic wax sensor

Dirt separator

Body: brass EN 1982 CB753S
Dirt collection chamber: brass EN 12165 CW617N
Internal element: stainless steel EN 10088-2 (AISI 304)
Hydraulic seals: EPDM
Drain valve: brass EN 12165 CW617N

Heat exchanger

Body: brazed stainless steel

Diverter valve with spring return

Body: brass EN 12165 CW617N
Obturator stem: stainless steel EN 10088-2 (AISI 303)
Obturator: EPDM
 Δp max: 1 bar

Shut-off valves

Body: brass EN 12165 CW617N
Ball: brass EN 12164 CW614N
Seal elements: EPDM

Performance

Medium: water, glycol solutions
Max. percentage of glycol: 30%
Max. working pressure: 10 bar
Working temperature range: 5–100°C
Anti-condensation setting temperature (Tset): 45°C, 55°C, 60°C, 70°C
Setting accuracy: $\pm 2^\circ\text{C}$
By-pass complete closing temperature: $T_{mix} = T_{set} + 10^\circ\text{C} = T_r$
Max. heat exchanger net output: 35 kW
Max. recommended primary circuit flow rate: 1,5 m³/h
Max. recommended secondary circuit flow rate (system): 1,5 m³/h

Connections: 3/4" M (ISO 228-1)

Regulator

Electric supply: 230 V - 50 Hz
Power consumption: 5,5 VA
Protection class: IP 40

Diverter valve actuator with spring return

Synchronous motor
Normally closed
Electric supply: 230 V - 50 Hz
Power consumption: 6,5 W; 7 VA
Opening time: 70–75 s
Closing time: 5–7 s
Auxiliary microswitch contact rating: 0,8 A
Protection class: IP 40
Maximum room temperature: 40°C
Complies with Directives: 73/23/EC and 89/336/EC

Temperature probe for solid fuel generator (supplied) and solar thermal circuit (optional)

NTC type
Working temperature range: -20–100°C
Two-wire cable

Temperature probe for solar thermal circuit (optional)

Type Pt1000 3 m SIHF cable, 2x0,5 mm² Tmax 180°C

Pump

High efficiency pump:
- primary side, solid fuel generator: model YONOS PARA 25/6
- secondary side, system: model YONOS PARA 15/6

Material

Body: cast iron GG 15/20
Electric supply: 230 V - 50 Hz
Max. ambient humidity: 95%

Max. ambient temperature: 80°C
Protection class: IPX4D
Pump centre distance: 130 mm
Pump connections:
- primary side, solid fuel generator: 1 1/2" with nut
- secondary side, system: 1" with nut

Heat exchanger insulation

Material: closed cell expanded PE-X
Thickness: 20 mm
Density:
- inner part 30 kg/m³
- outer part 50 kg/m³
Thermal conductivity (DIN 52612):
- at 0°C 0,038 W/(m·K)
- at 40°C 0,045 W/(m·K)
Coefficient of resistance to diffusion of water vapour (DIN 52615): > 1300
Working temperature range: 0–100°C
Reaction to fire (DIN 4102): class B2

Head available at unit connections

Primary side YONOS PARA 25/6

Solid fuel generator flow/return connections

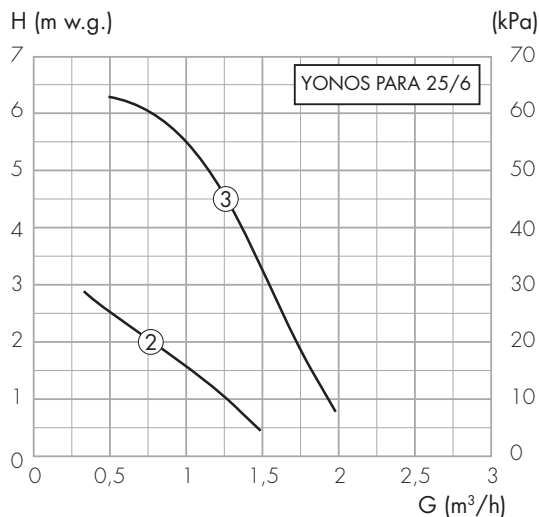

Secondary side YONOS PARA 15/6

Heating system flow/return connections

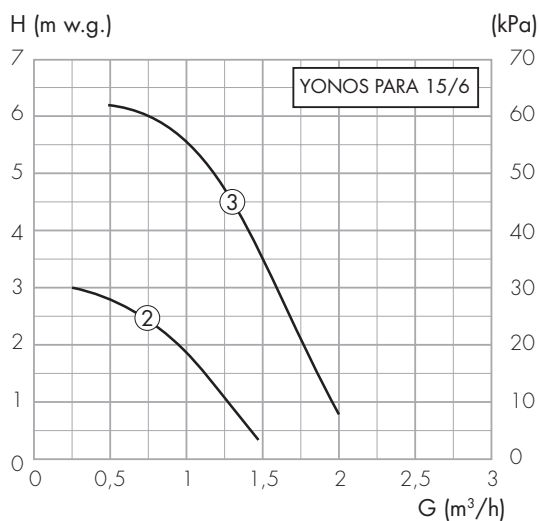

Dimensions

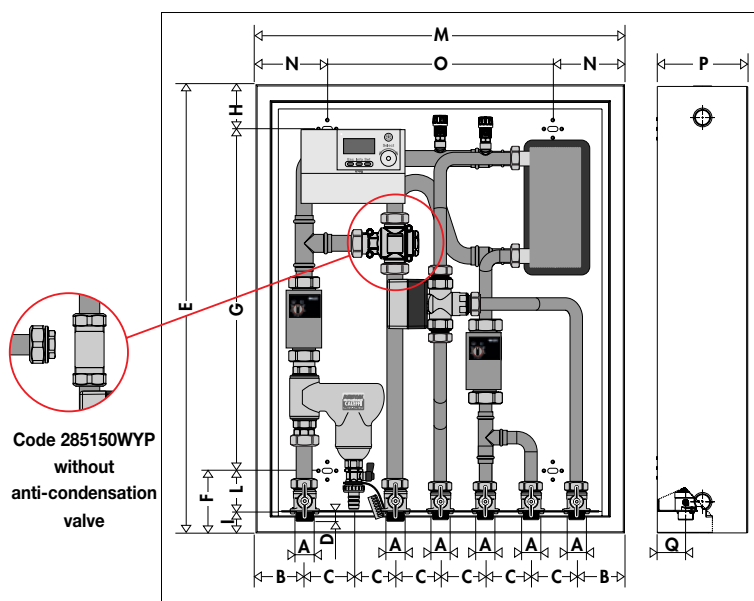

code	A	B	C	D	E	F	G	H
28515.WYP	3/4"	85	80	15	790	115	600	75
	I	L	M	N	O	P	Q	Mass (kg)
	38	77	650	125	400	160	50	30

• Code completion

Setting	45°C	55°C	60°C	70°C
•	4	5	6	7

• = 0 Without anti-condensation valve

Connecting circuit between integration gas boiler and heating system (diverter valve + pipes): Kv (m³/h) = 4,5

Note:

The YONOS PARA pump can operate with proportional pressure control, which adapts the performance to the system requirements. For further details, see the installation instruction sheet of the pump supplied in the package.

Wooden biomass and condensation build-up

Wooden solid fuel contains a variable moisture percentage depending on the type (logs, pellets, woodchips etc.) and seasoning. Water vapour is released during the solid fuel drying phase inside the combustion chamber. The presence of cold zones in the generator or flue gas chimney can lower the temperature of the flue gas down to the dew point, causing condensation to occur. Water vapour condenses on the generator surfaces, together with soot and part of the unburned hydrocarbons contained in the flue gas, producing deposits and tar. These substances stick to the walls of the generator, covering most of the inner surfaces. In addition to being dangerous due to its flammability, tar is damaging to the integrity of the generator and limits the efficiency of the flue gas-system water exchanger.

By keeping the generator walls at the highest possible temperature, the anti-condensation valve (optional) incorporated into the unit limits the formation of these substances, thereby increasing the combustion efficiency, controlling the emissions into the environment and prolonging the generator life.

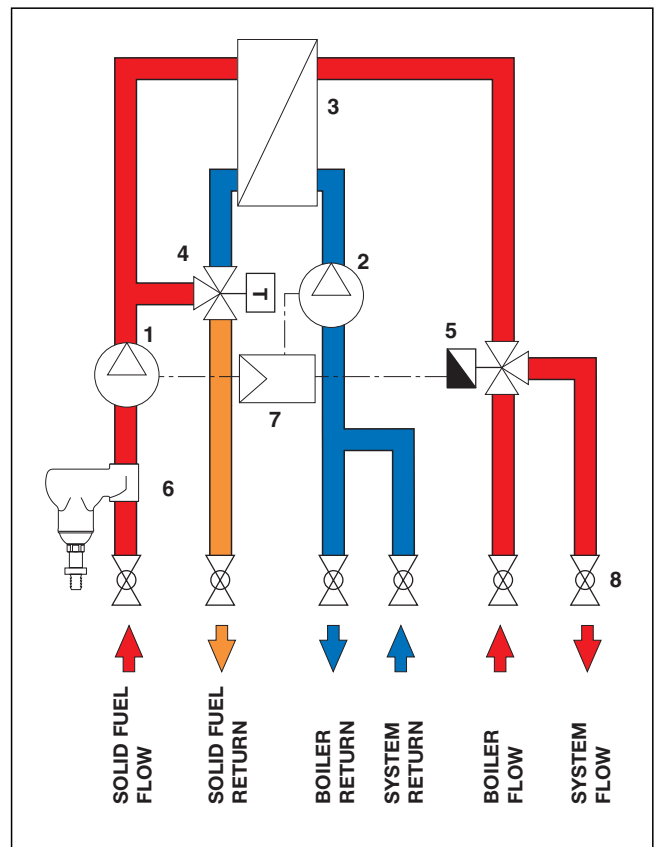
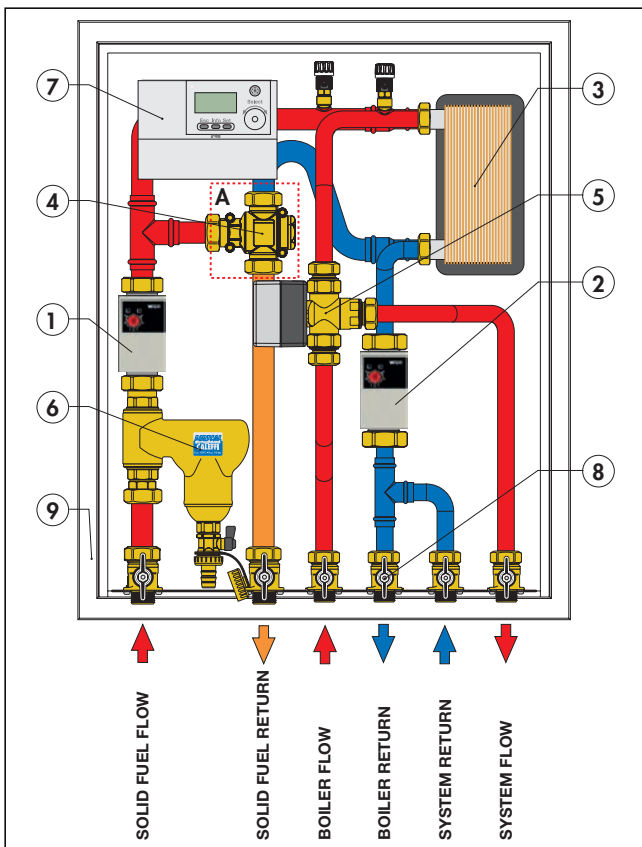
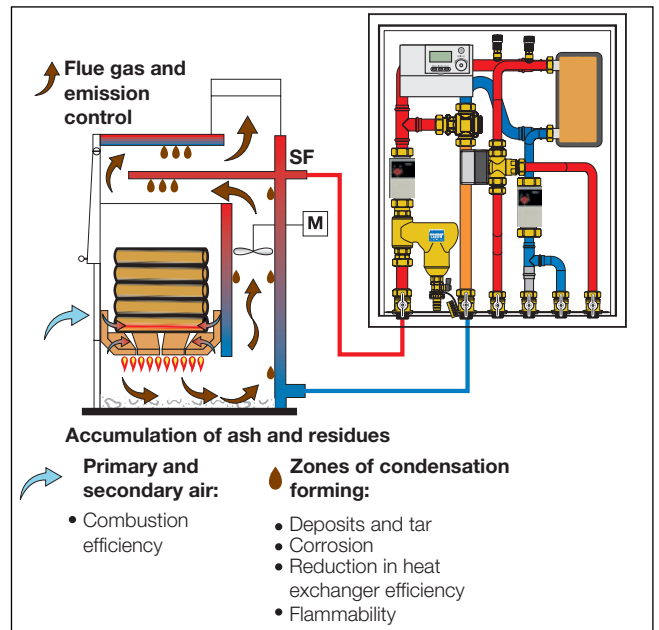

Characteristic components

- 1) Wilo YONOS PARA 25/6 pump on primary side for solid fuel generator
 - 2) Wilo YONOS PARA 15/6 pump on secondary side (system)
 - 3) Brazed plate heat exchanger
 - 4) Anti-condensation valve (optional)
 - 5) Three-way diverter valve with spring return
 - 6) Dirt separator
 - 7) Digital regulator
 - 8) Shut-off ball valves
 - 9) Box for exposed installation
- A) Code 285150WYP without anti-condensation valve

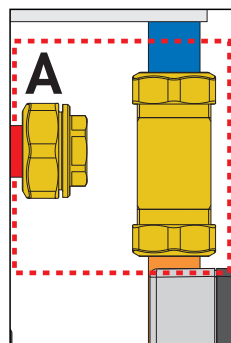

Code 285150WYP without anti-condensation valve

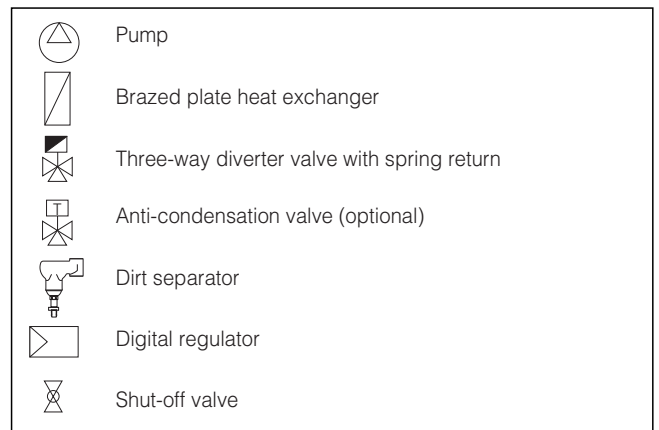

Operating conditions

The digital regulator automatically manages the unit's operation, receiving the signal from the probes and activating the pumps, the motorized valve and the generators. The heating circuit is managed according to needs.

The room thermostat RT provides the regulator with information regarding the room temperature. When the room calls for thermal energy, the regulator activates either the solid fuel generator, with priority by checking the temperature with the probe S1 and operating the contact K, or alternatively activates the integration boiler by means of the contact C. The connection of the solid fuel generator with the secondary system is made via the plate heat exchanger, through the operation of the three-way motorized diverter valve with spring return V1 and the activation of the circulation pumps P1 and P2 (fig. 1). The connection of the integration boiler to the secondary system is performed by operating the motorized three-way valve V1 and simultaneously switching off the circulation pumps P1 and P2. In this situation, the secondary system receives energy directly from the integration boiler (fig. 2).

Heating with solid fuel generator

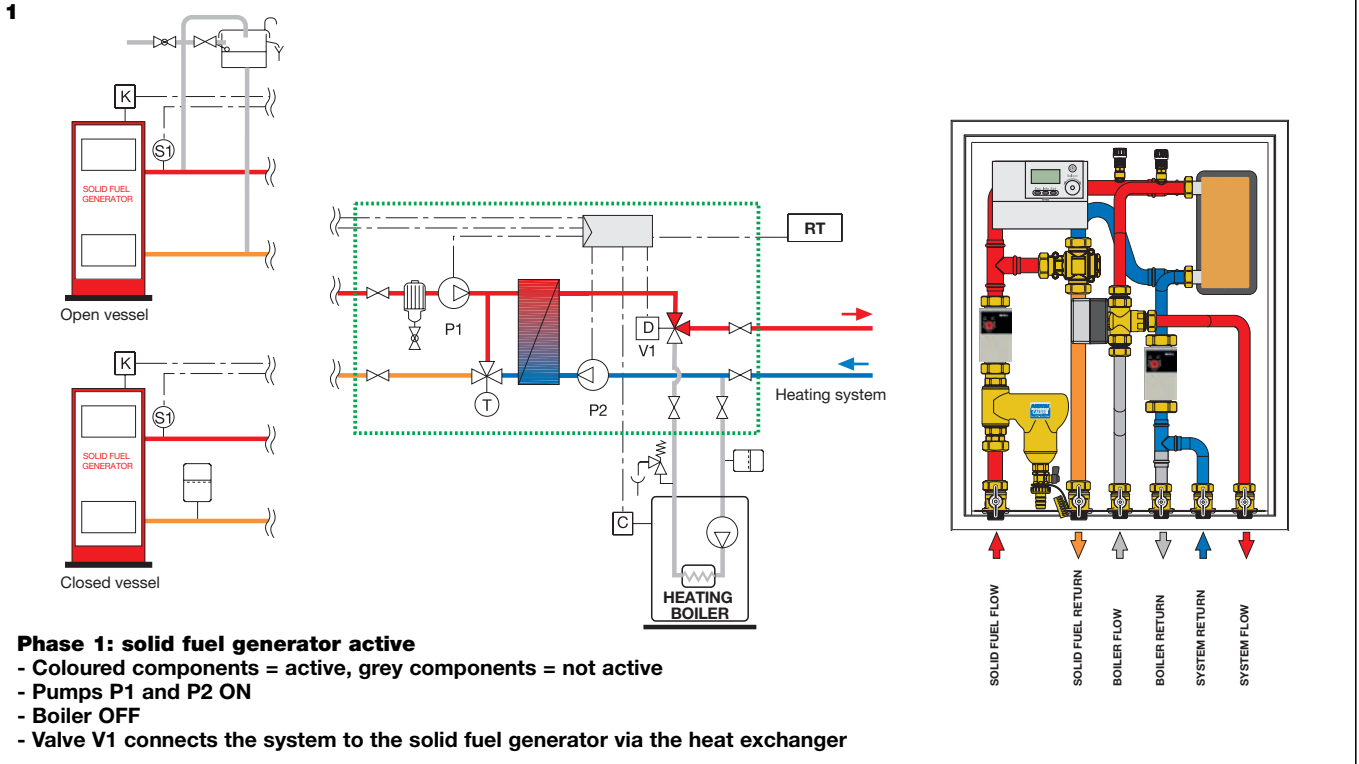

Heating with boiler

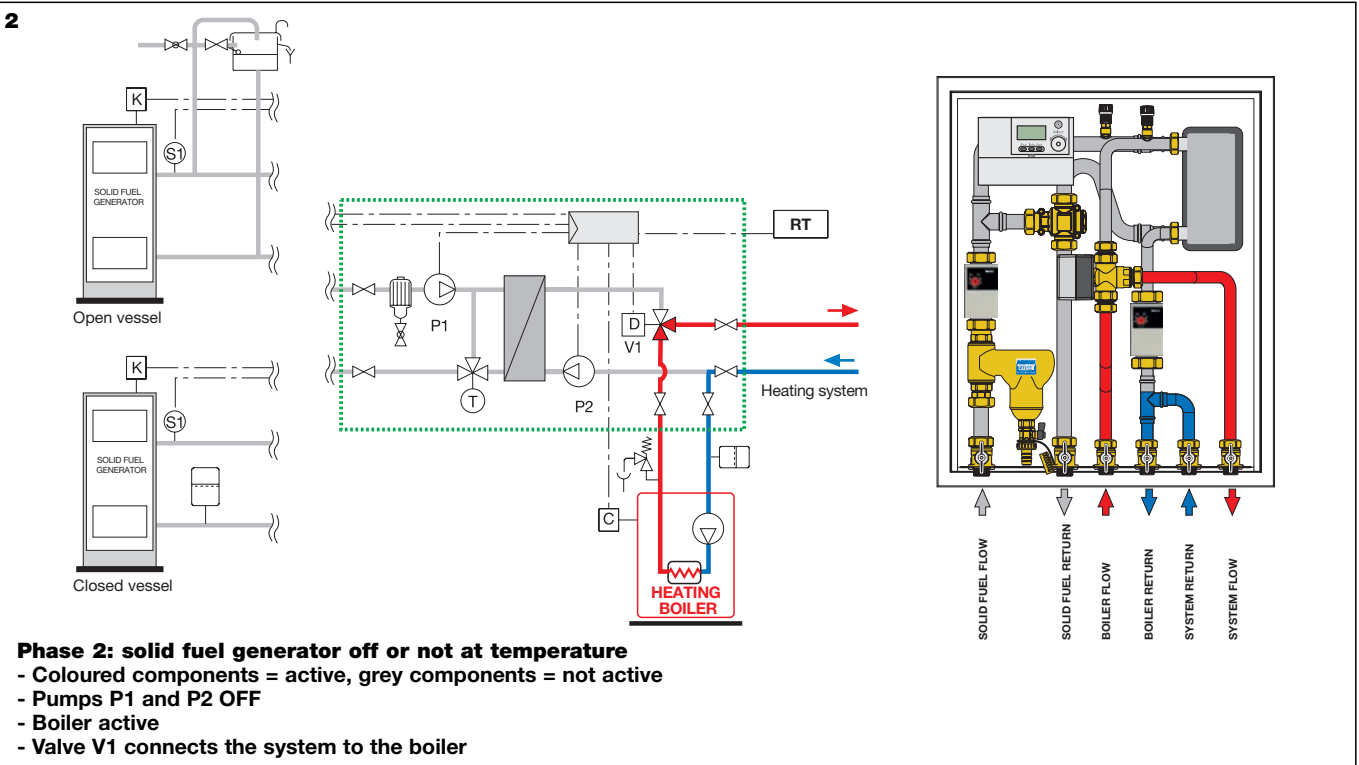

Construction details

Anti-condensation valve (optional)

The device incorporates a thermostatic sensor to control the temperature of water returning to the solid fuel generator so as to prevent condensation. The sensor has been specifically realised to be removed from the valve body for maintenance or replacement if necessary.

Maintenance and setting modification

The adjustment sensor of the anti-condensation valve (optional) can easily be removed for maintenance or setting change, according to the following procedure:

- close the shut-off valves of the primary circuit to isolate the anti-condensation valve from the system;
- remove the anti-condensation valve from the unit;
- unscrew the cap of the anti-condensation valve;
- take out the unit consisting of the spring, obturator and thermostatic sensor, noting the position of each component;
- perform maintenance or replace the sensor with a spare part, fitting it in the same position;
- re-fit the unit consisting of the spring, obturator and thermostatic sensor inside the valve body, positioned vertically;
- screw the cap back onto the valve body;
- re-fit the anti-condensation valve onto the unit with the port marked by the flame symbol pointing the solid fuel generator;
- if the thermostat is replaced with a spare part featuring a different setting, apply the label indicating the new setting to the cap, label supplied in the spare part packaging.

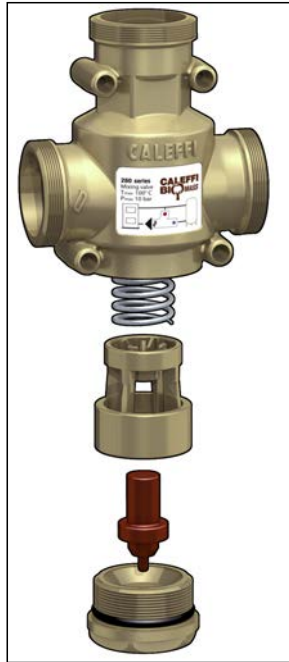

Heat exchanger

The presence of the heat exchanger allows the connection of an open or closed vessel solid fuel generator (or other type of generator) to a system, new or already in place, equipped with another type of closed vessel generator. The heat exchanger represents a hydraulic break, in other words a physical separation between the two circuits, therefore the power outputs of the two generators are not added together, as indicated by INAIL (Italy).

The heat exchanger also helps to protect the integrity of the solid fuel generator, since it physically separates the two circuits and prevents impurities in the existing circuit from clogging the solid fuel generator.

Three-way diverter valve with spring return

The three-way diverter valve provides a further mechanical separation between the primary circuit and the secondary circuit. In the event of an electric supply failure, the valve positions itself mechanically in diversion towards the generator of the secondary side, thereby guaranteeing that only one of the two generators actually remains connected to the system. The valve also enables correct circulation of the medium, without any need to install check valves.

Dirt separator

To allow continuous removal of dirt from the primary circuit connected to the solid fuel generator, the unit is equipped as standard with a DIRTICAL® vertical dirt separator.

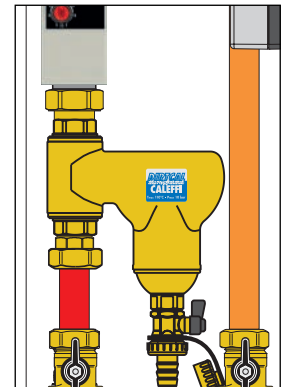

Installation

The connection and energy management unit is supplied preassembled in a box for wall installation. The unit can be installed only in vertical position, with all the threaded connections pointing downwards.

It is recommended to clean accurately the existing system, so as to minimize clogging problems at the heat exchanger. For this purpose, it is advisable to install strainers of suitable capacity in the existing secondary system as well, to ensure a continuous cleaning action.

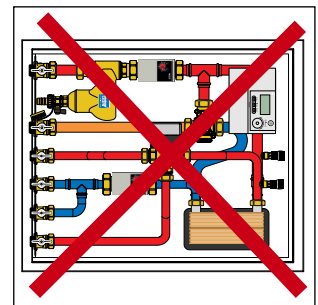
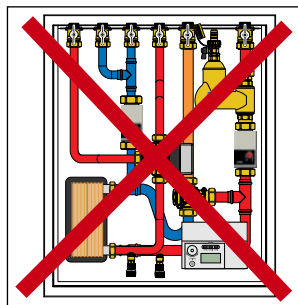
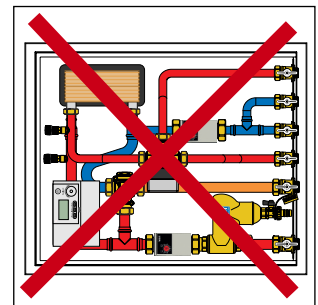
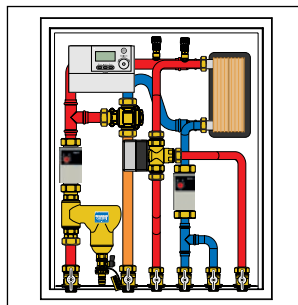

Digital regulator

The digital regulator automatically manages the unit's operation, receiving the signal from the probes and activating the pumps, the motorized valve and the generators, according to the heating system needs.

The regulator has a display for the activation of preset programs and for viewing and setting control parameters, such as cut-in temperatures, delay times for the activation of functions, etc.

In addition to programs controlling the operation of the heating system, the device also activates automatic monitoring and safety functions to protect the system, including antiblock for the pumps and diverter valve, anti-freeze, overtemperature control for the solid fuel generator etc.

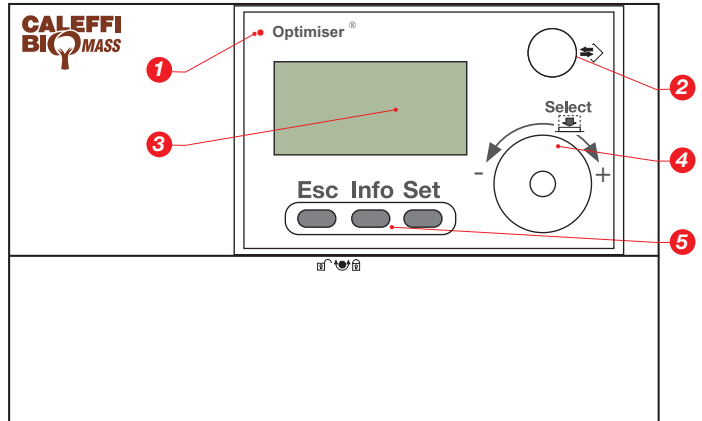

Description of controls

1. Operating status indicator LED.
2. Mini DIN connector on front of panel for PC connection.
3. Display: visualisation of menu.
4. Select knob: selection of menu, functions and parameter changes.
5. Function buttons.

Optional programs

Besides the functionality of the heating system, the regulator menu includes a specific section to manage independently the following circuits:

- **storage in parallel on the heating circuit** (diagram P): the storage is loaded by the surplus energy provided by the solid fuel generator. The storage functions as a reserve of energy to be utilized in response to the next call for heat from the user circuit.
- **simple solar thermal circuit** (diagram A) composed of solar collector and domestic hot water storage: the regulator activates the circulation pump of the solar unit by checking the temperature differential between the top of the solar panels and the bottom part of the storage;
- **loading of two storages** (diagram B): when reaching the temperature differential between the two storages, the regulator activates the pump to transfer energy from the priority storage 1 to the secondary storage 2.

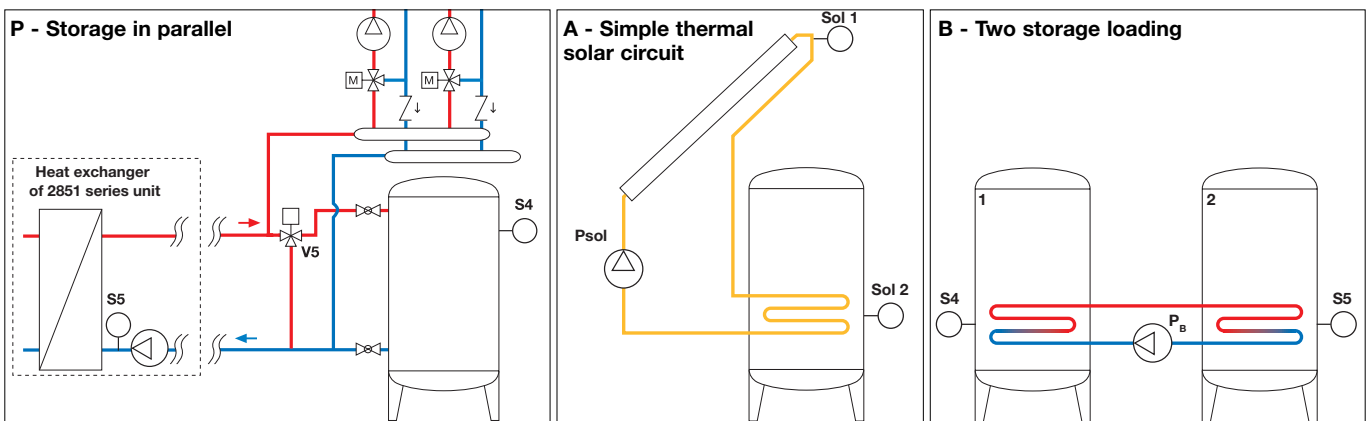

If there are no special needs, the factory-set parameters of the regulator ensure optimum operation of the system without further changes.

For operating details of the various programs, see instruction sheets 28169 and 28180.

Electric connections

The 2851 unit is provided internally pre-wired. The cables emerging from the unit should be connected by the installer as follows:

- 1) contact **K** for the activation of the solid fuel generator (check the presence of regulator/contact on board the generator);
- 2) probe **S1** to be applied on the solid fuel generator flow pipe;
- 3) contact **C** for the activation of the integration gas boiler;
- 4) contact for room thermostat **RT**;
- 5) electric supply **230 V**.

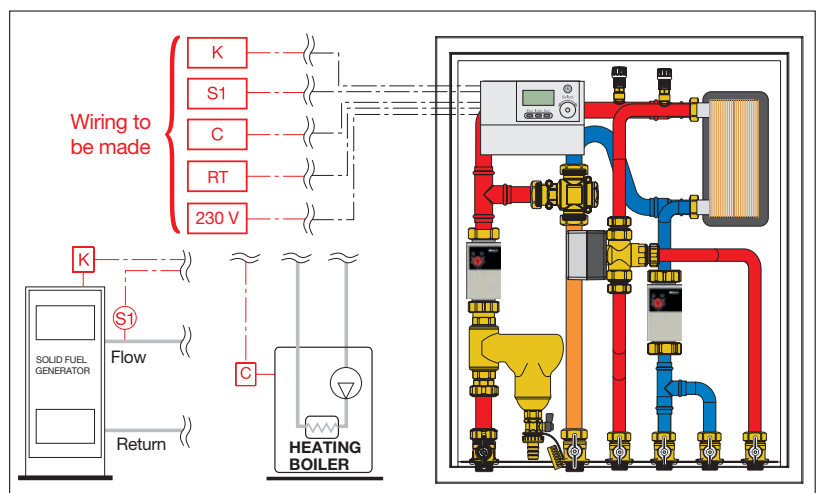

Application diagram

Solid fuel generator combined with auxiliary boiler for direct heating.

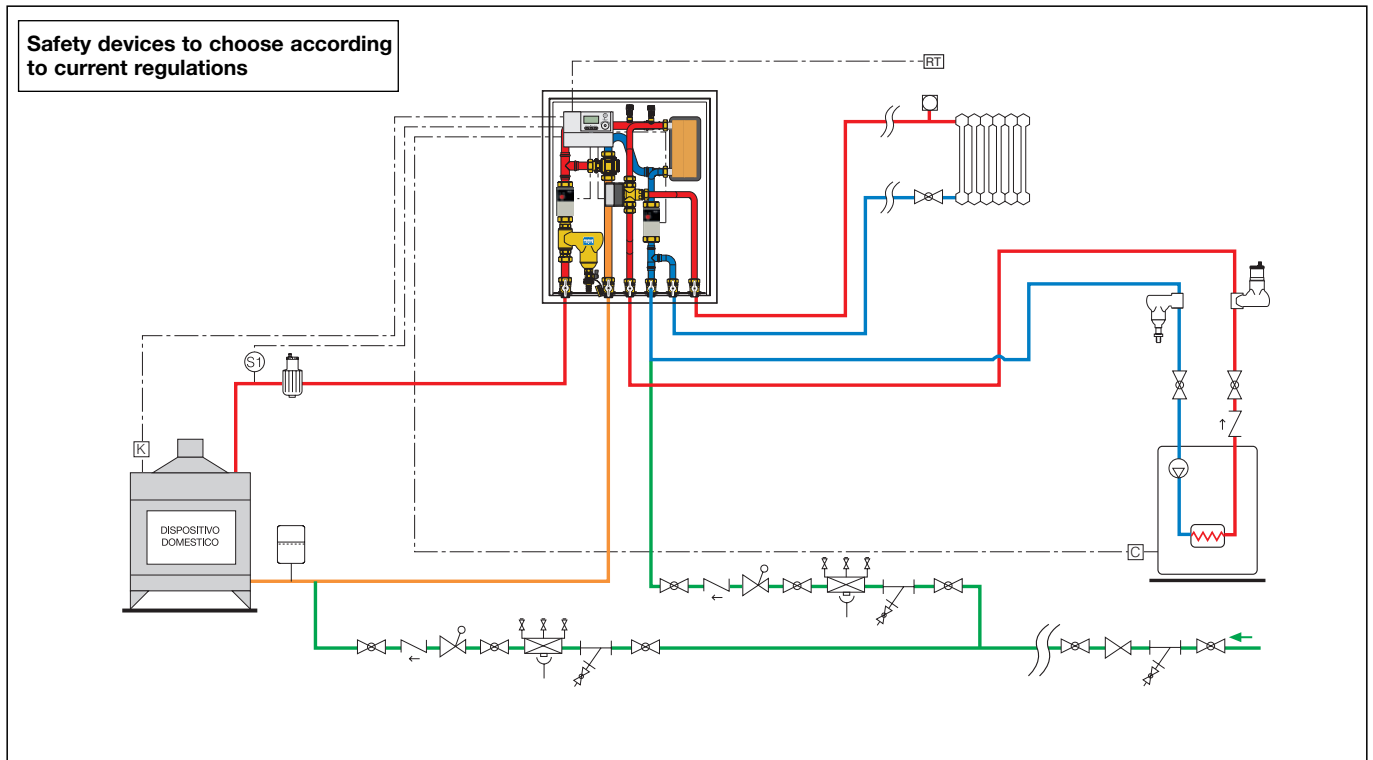

Solid fuel generator, combined with auxiliary boiler for direct heating by way of hydraulic separator

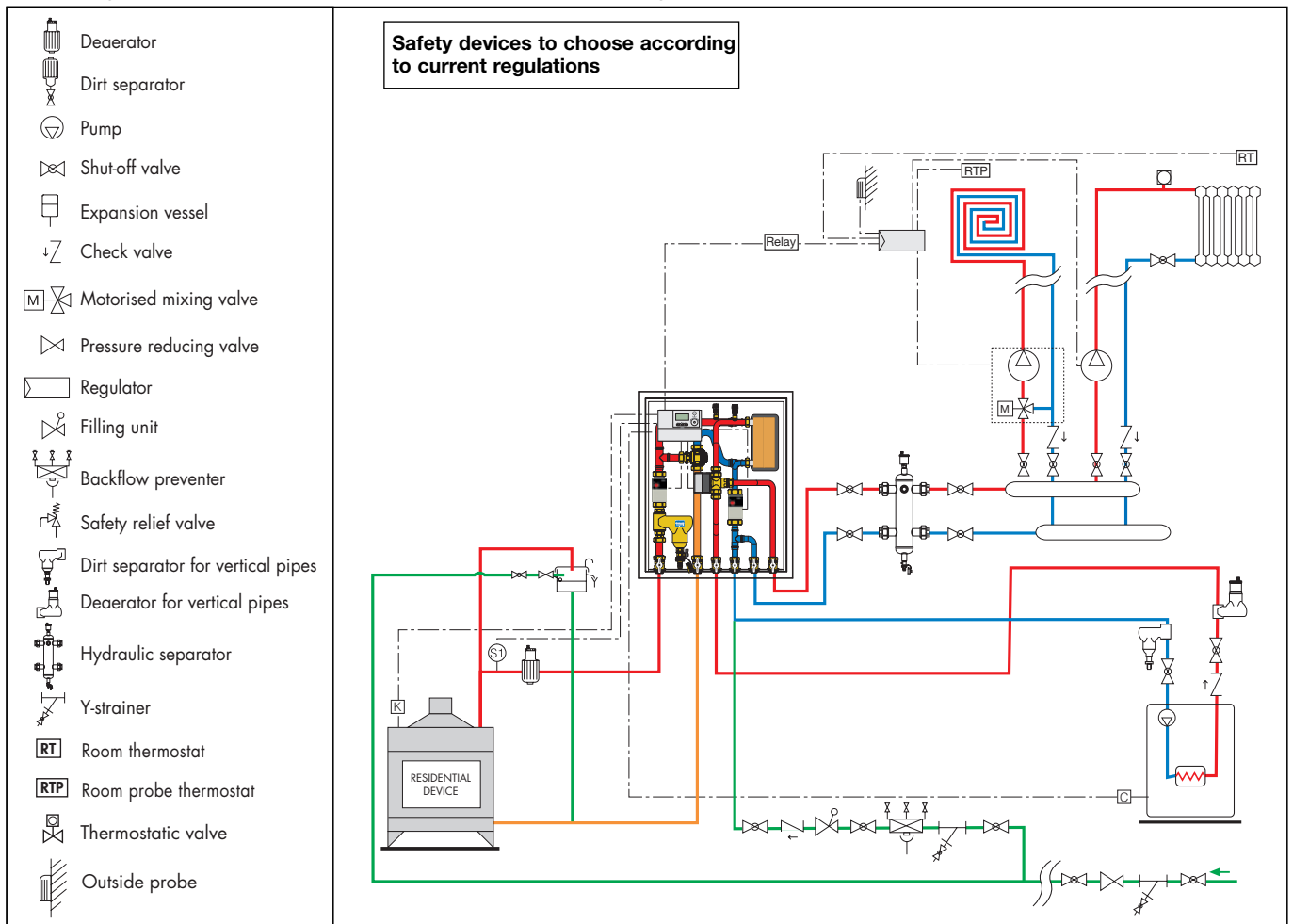

Solid fuel generator, combined with auxiliary boiler for heating with water storage in parallel

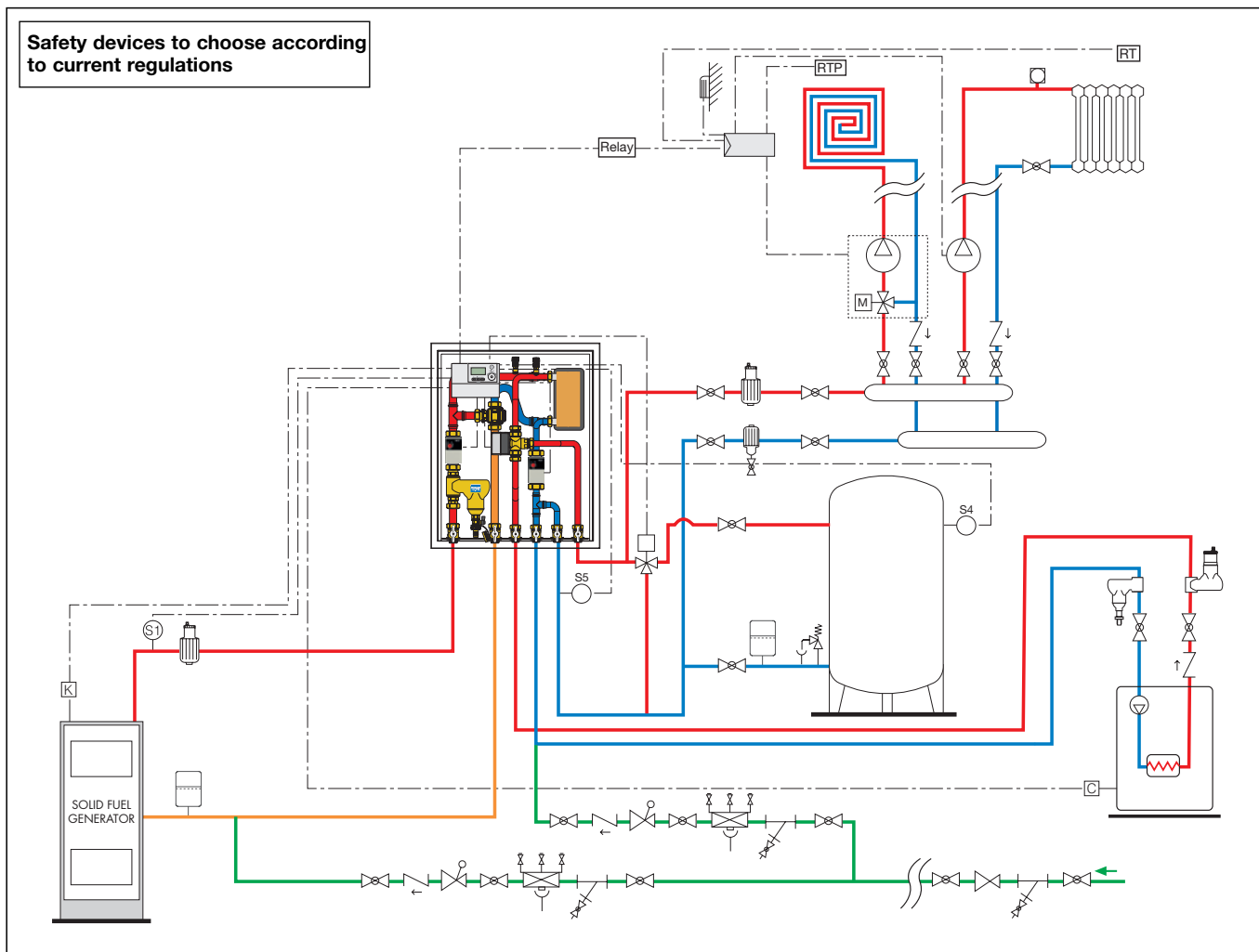

SPECIFICATION SUMMARY

2851 series

Connection and energy management unit, heating version. Connections 3/4" M (ISO 228/-1). Copper connection pipes. Medium water and glycol solutions. Maximum percentage of glycol 30%. Maximum working pressure 10 bar. Working temperature range 5–100°C. Complete with: anti-condensation valve (optional) with brass body, brass cap, PSU obturator, stainless steel spring, EPDM seal, anti-condensation temperature setting 45°C, 55°C, 60°C, 70°C, setting accuracy $\pm 2^\circ\text{C}$, by-pass complete closing temperature $T_{\text{set}} + 10^\circ\text{C}$; brazed plate heat exchanger with stainless steel body, complete with insulation, maximum net output 35 kW, maximum recommended primary circuit flow rate 1,5 m³/h, maximum recommended secondary circuit (system) flow rate 1,5 m³/h; manual air vents with brass body, POM knob, colour white RAL 9010, PTFE external seal, POM/EPDM internal seal; dirt separator with brass body, brass dirt collection chamber, stainless steel internal element, EPDM hydraulic seals, brass drain valve; shut-off valves with brass body and ball, EPDM sealing element; diverter valve with spring return, brass body, stainless steel obturator stem, EPDM obturator, actuator with synchronous motor, normally closed, electric supply 230 V - 50 Hz, opening time 70–75 s, closing time 5–7 s, protection class IP 40, maximum ambient temperature 40°C, compliance with Directives 73/23/EC and 89/336/EC; digital regulator complete with probe for solid fuel generator, electric supply 230 V - 50 Hz, protection class IP 40; high-efficiency pumps, model YONOS PARA 25/6 (primary side, solid fuel generator) and model YONOS PARA 15/6 (secondary side, system) with cast iron body, electric supply 230 V - 50 Hz, maximum ambient humidity 95%, maximum ambient temperature 80°C, protection class IPX4D. NTC type temperature probe for solid fuel generator; NTC and Pt1000 optional probe for simple solar thermal circuit. Provided preassembled in painted sheet metal box for wall installation. Closure with a push-fit clamp.

We reserve the right to change our products and their relevant technical data, contained in this publication, at any time and without prior notice.