

Anti-condensation recirculation and distribution unit

281 series

CALEFFI
BIO MASS



01224/14 GB
Replaces dp 01224/12 GB



Function

The anti-condensation recirculation and distribution unit enables the connection of the solid fuel generator to the user system (direct or with inertial storage). It controls the return temperature to the generator to avoid condensation, by means of the built-in thermostatic sensor.

Keeping the generator at a high temperature prevents condensation of the water vapour contained in the flue gas.

It can be used both on boilers and residential generators such as fireplace heating systems, thermostoves and thermocookers.

The anti-condensation recirculation and distribution unit gives the generator a longer life and ensures greater efficiency.

The compact unit incorporates a circulation pump, an anti-condensation thermostatic sensor, a natural circulation clapet valve, the temperature gauges and is equipped with an insulation shell.



Product range

Code 2810.. Anti-condensation recirculation and distribution unit _____ size DN 25 (1" and 1 1/4")
Code 2810..YYP Anti-condensation recirculation and distribution unit with high-efficiency pump _____ size DN 25 (1" and 1 1/4")

Technical specifications

Materials

Body: brass EN 1982 CB753S
Obturator locking nut: brass EN 12164 CW614N
Unions: brass EN 12165 CW617N
Ball built into the unions: brass EN 12164 CW614N
Obturator: PSU
Spring: stainless steel EN 10270-3 (AISI 302)
Clapet valve: PPS
Seal elements: EPDM

Performance

Medium: water, glycol solutions
Maximum percentage of glycol: 50%
Max. recommended flow rate: 2 m³/h
Max. working pressure: 10 bar
Working temperature range: 5–100°C
Temperature gauge scale: 0–120°C

Connections: 1" and 1 1/4" F (ISO 228-1) with union

Anti-condensation valve

Setting temperature (Tset): 45°C, 55°C, 60°C, 70°C
Setting accuracy: ±2°C
By-pass complete closing temperature: T_{mix}=T_{set} + 10°C=Tr

Pump

Three-speed pump: model RS 4-3
High-efficiency pump: YONOS PARA 25/6
Electric supply: 230 V - 50 Hz
Max. ambient humidity: 95%
Max. ambient temperature: 80°C
Protection class: - RS 4-3 IP 44
- YONOS PARA 25/6 IPX4D

Head available at the unit connections

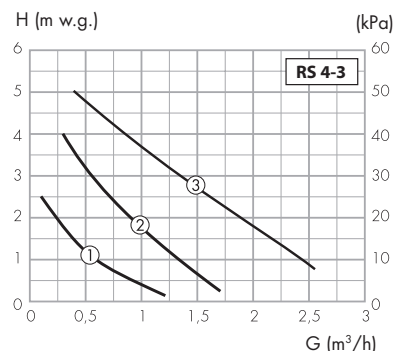

Power consumption

Speed	n (rpm)	P (W)	I (A)
3	2050	65	0,28
2	1650	45	0,20
1	1300	30	0,13

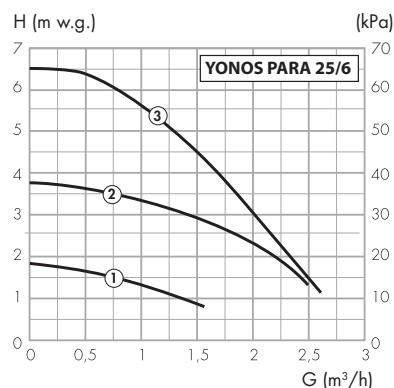

Note:

The YONOS PARA pump can operate with proportional pressure control, which adapts the performance to the system requirements. For further details, see the installation instruction sheet of the pump supplied in the package.

Technical specifications of insulation

Material:	EPP
Mean thickness:	30 mm
Density:	45 kg/m ³
Working temperature range:	5–100°C
Thermal conductivity:	0,037 W/(m·K) at 10°C
Reaction to fire (UL94):	class HBF

Dimensions

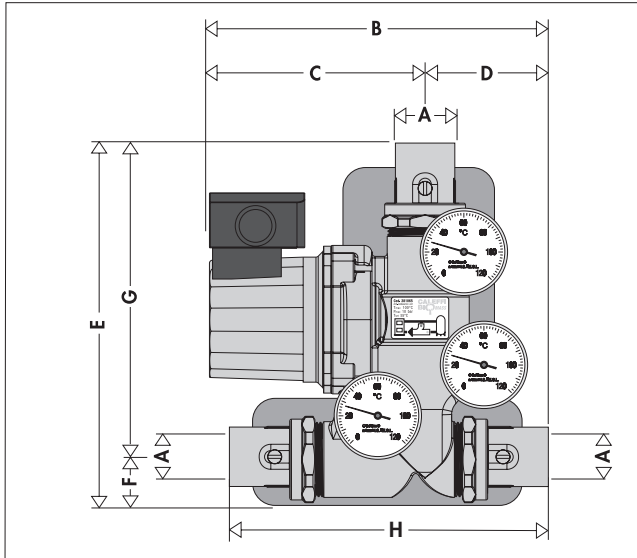

Code	DN	A	B	C
28106./28106.WYP	25	1"	221,5/223	143/144,5
28107./28107.WYP	25	1 1/4"	221,5/227	143/144,5

D	E	F	G	H	Mass (kg)
78,5	249,5	47	202,5	203	4,85/4,41
78,5	253	47	206	210	5,15/4,71

• Code completion

Setting	45°C	55°C	60°C	70°C
•	4	5	6	7

Wooden biomass and condensation build-up

Wooden solid fuel contains a variable moisture percentage depending on the type (logs, pellets, woodchips etc.) and seasoning. Water vapour is released during the solid fuel drying phase inside the combustion chamber.

The presence of cold zones in the generator or flue gas chimney can lower the temperature of the flue gas down to the dew point, causing condensation to occur. Water vapour condenses on the generator surfaces, together with soot and part of the unburnt hydrocarbons contained in the flue gas, producing deposits and tar. These substances stick to the walls of the generator, covering most of the inner surfaces.

In addition to being dangerous due to its flammability, tar is damaging to the integrity of the generator and limits the efficiency of the flue gas-system water exchanger.

By keeping the generator walls at the highest possible temperature, the anti-condensation recirculation and distribution unit limits the formation of these substances, thereby increasing the combustion efficiency, controlling the emissions into the environment and prolonging the generator life.

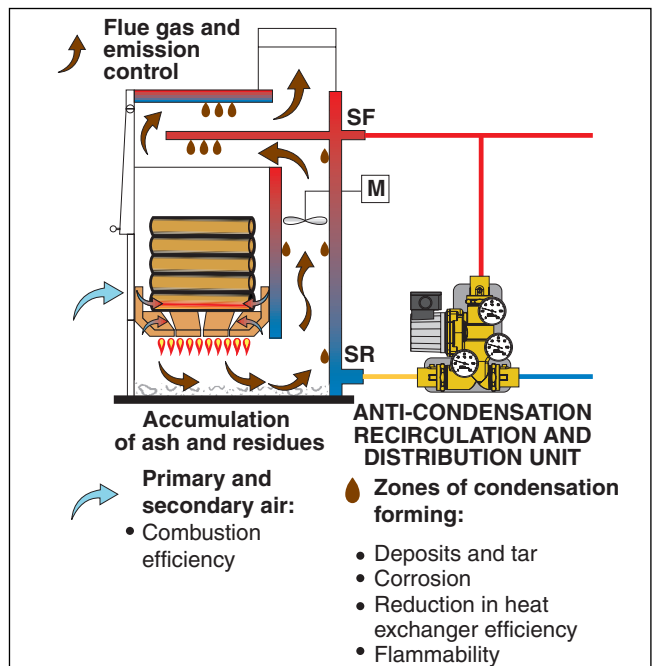

Characteristic components

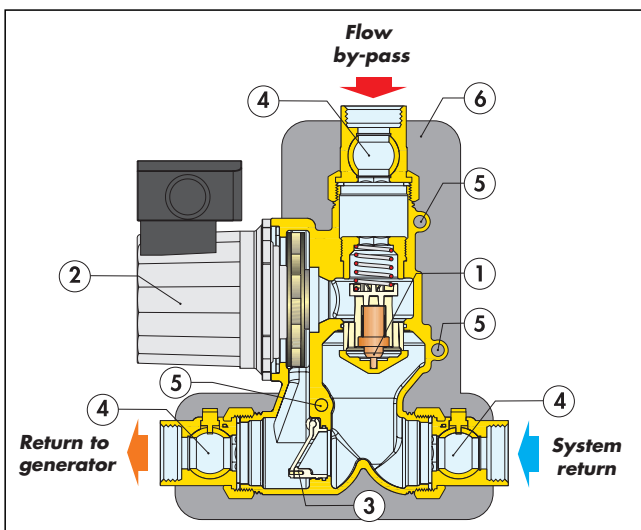

- 1) Anti-condensation thermostatic sensor
- 2) Three-speed pump/ high-efficiency pump
- 3) Natural circulation clapet valve
- 4) Union with built-in ball valve
- 5) Temperature gauge housing
- 6) Insulation

Hydraulic diagram

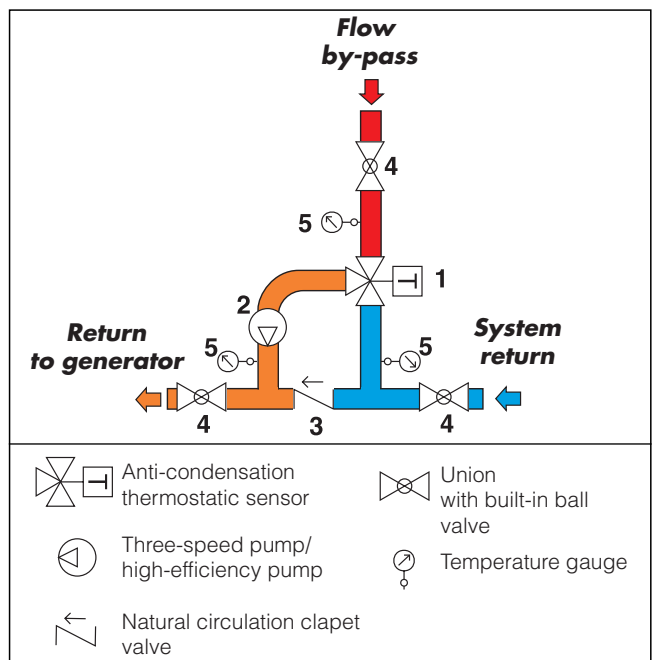

Operating principle

The thermostat (1), completely immersed in the medium, controls the movement of an obturator (2) that regulates the flows in by-pass (3) and toward the system. At the start-up of the heat generator, the recirculation unit recirculates the flow water so as to bring the generator up to temperature as quickly as possible (fig. 1). When the flow temperature T_f exceeds the setting of the anti-condensation valve T_{set} , the unit's cold port (4) starts opening to produce the water mixing T_{mix} : in this phase the system loading begins (fig. 2). When the return temperature to the generator T_{mix} is greater than the setting of the anti-condensation valve by approximately 10°C, the by-pass port (3) closes and water returns to the generator at the same temperature as the system return (fig. 3). In the event of pump stop (5), the clapet valve (6), which is closed due to the thrust of the pump during normal operation, allows natural circulation of the medium, by-passing the anti-condensation valve (1) in order to dissipate heat and prevent the temperature in the generator from reaching high levels that could be dangerous for the system safety (fig. 4).

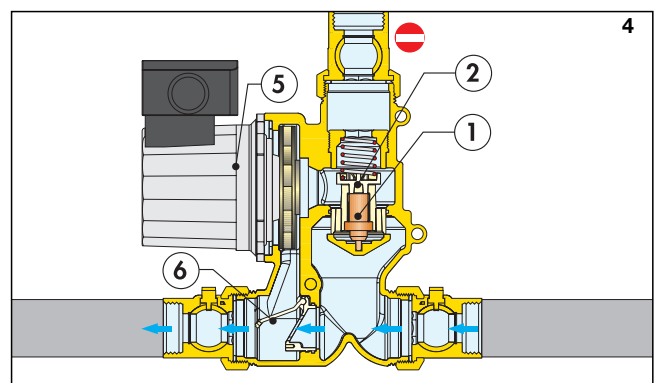
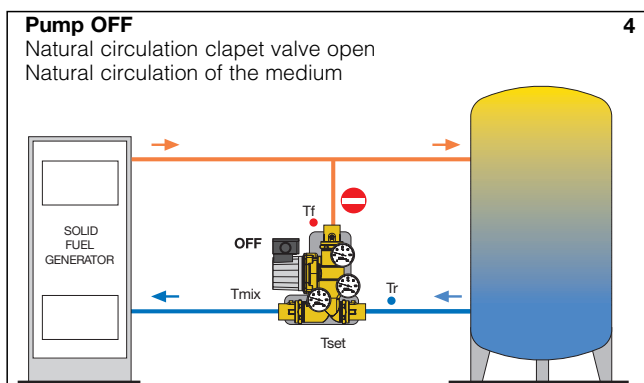
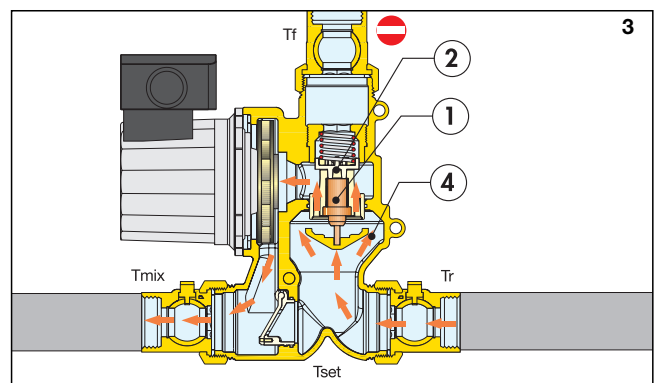
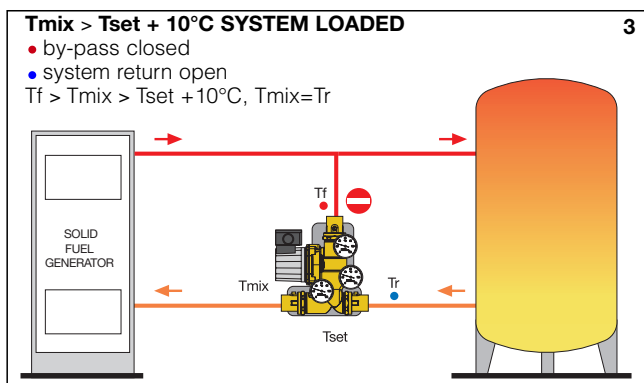
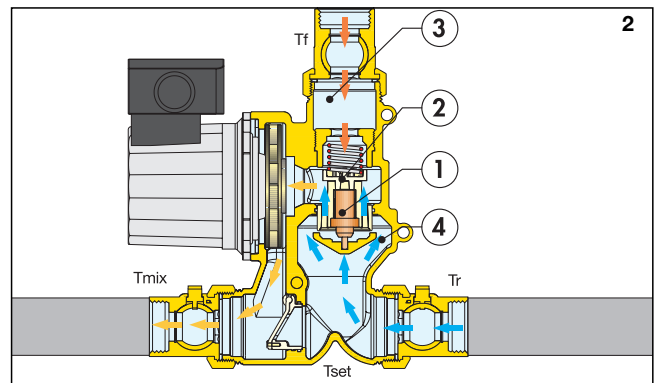
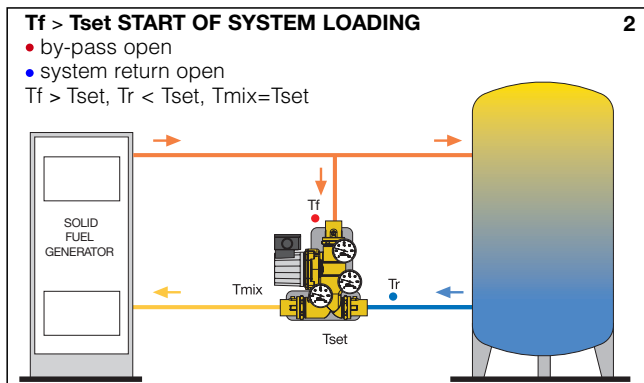
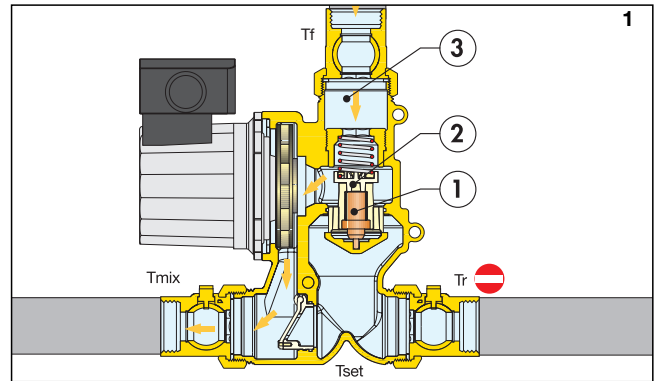
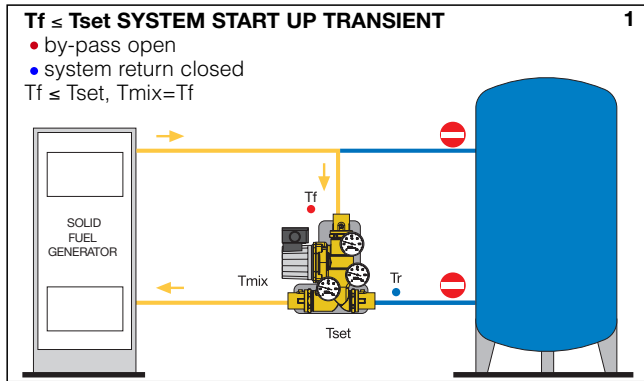

T_f = Flow temperature
 T_{set} = Anti-condensation setting temperature

T_{mix} = Mixed water temperature of generator return
 T_r = System return temperature

Construction details

Single casting and reversibility

The compact brass single casting, that houses the pump and functional components, enables immediate installation of the device, either on the right or left of the solid fuel generator, respecting the flow directions as shown. The temperature gauges can be extracted from the housings and re-inserted in the same position on the back side of the unit.

Brass body

The brass body prevents the formation of ferrous residues in the system, thereby helping to prolong the life of the heat generator.

Anti-condensation valve

The device incorporates a thermostatic sensor to control the temperature of water returning to the solid fuel generator so as to prevent condensation. The sensor has been specifically realised to be removed from the valve body for maintenance or replacement if necessary.

Natural circulation clapet valve

The function of this clapet device is to ensure natural circulation of the medium in the event of pump stop due to an electric power failure. When the pump is active, the thrust of medium keeps the valve closed, forcing the water to flow through the anti-condensation thermostatic valve. In the event of pump stop, when the water within the generator is at high temperature, a natural circulation of the water begins, by-passing the anti-condensation valve, thus preventing the temperature in the generator from reaching dangerous high levels.

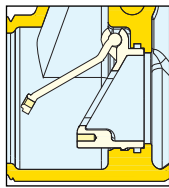

Clapet - lock

Before installation, it is necessary to remove the screw that keeps the clapet valve closed. This screw is factory supplied screwed in order to prevent breakage during transport. Removing the protective screw ensures the full functionality of the clapet valve as a natural circulation device. To do this, unscrew the union located on the mixed water outlet port of the unit and access the screw inside the valve body, unscrewing it using a cross-tip screwdriver.

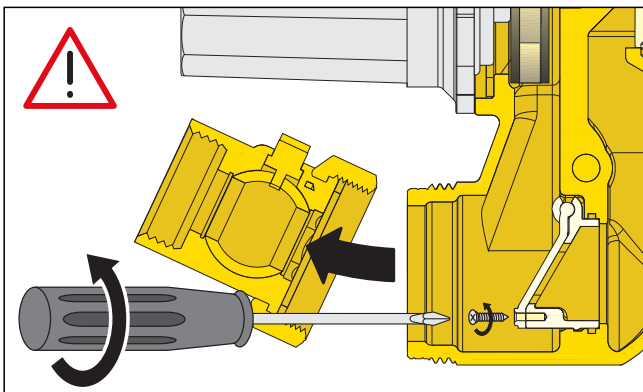

Dirt separator

In order to carry out continuous dirt separation in the system the 5462 series DIRTCAL® dirt separator is available as an accessory.

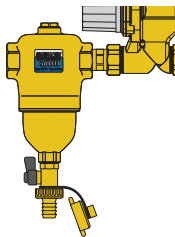

Insulation

The anti-condensation recirculation units are supplied with insulation shell to provide perfect thermal insulation.

Installation

The anti-condensation recirculation and distribution unit can be installed on both sides of the generator respecting the flow directions indicated on the body. Installation is only allowed on the return to the generator in mixing mode, in vertical position (axis of the pump horizontal and axis of the thermostatic sensor vertical). This permits the full mechanical and hydraulic functionality of the natural circulation clapet valve.

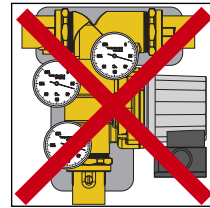
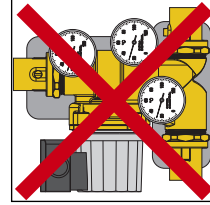
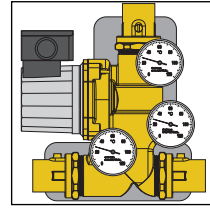

Installation on right side of generator

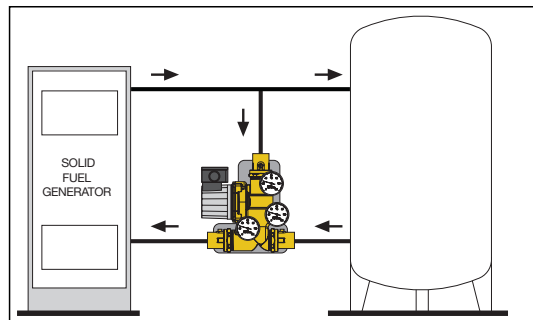

Installation on left side of generator

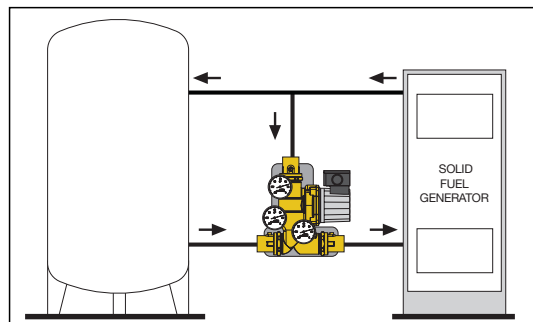

Maintenance / Setting modification

To remove the thermostatic sensor for maintenance or setting modification, proceed as follows, paying attention to the position of each component:

- 1) Remove the insulation and the temperature gauges, shut off the three ball valves built into the unions of the unit by means of a flat screwdriver or a 4 mm hexagonal spanner and remove the unit body from the pipes, fully unscrewing the unions with a 52 mm spanner (**fig. 1 and 2**).
- 1b) Alternatively, using a 52 mm hexagonal spanner slightly loosen nuts **B** and **C** and fully unscrew nut **A**. Rotate the unit on the **B-C** axis while still mounted on the pipe.
- 2) Using a 17 mm hexagonal spanner (**fig. 3**), unscrew and extract the obturator locking nut, entering through the upper by-pass port on the unit.
- 3) Extract the spring: fixed to it are the obturator and the thermostatic sensor (**fig. 4**).
- 4) Carry out maintenance or replace the thermostatic sensor with a suitable spare part. The sensor can be fully inserted into its seat with a slight interference.
- 5) Reassemble the obturator unit following the procedure in reverse order.

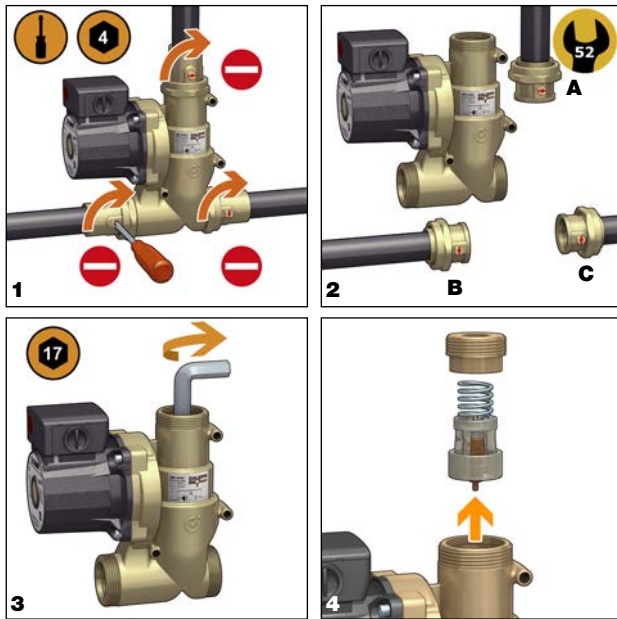

Application diagram

Solid fuel generator, system with inertial storage

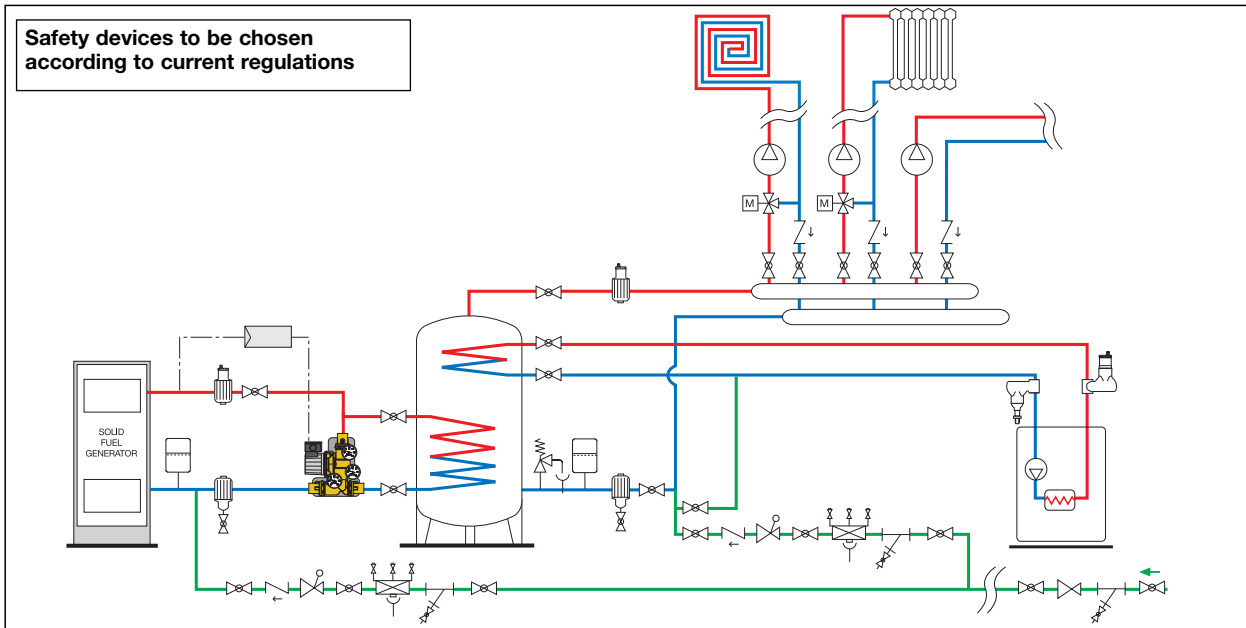

Solid fuel generator, connection to inertial storage in parallel

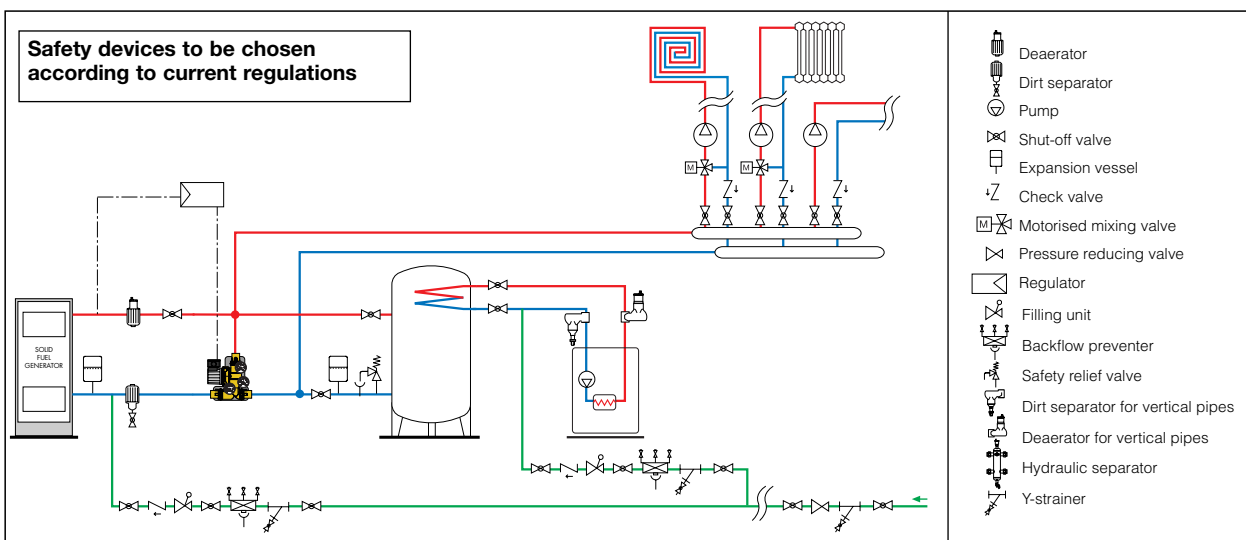

Solid fuel generator, direct supply to the system

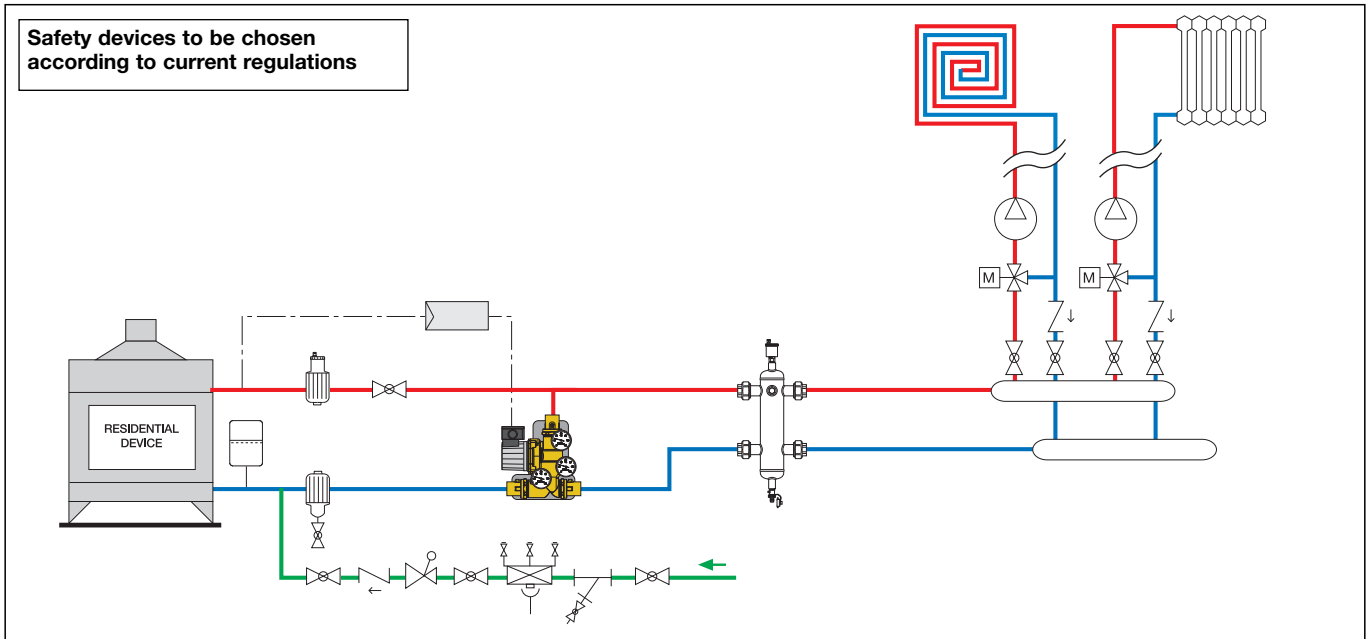

Solid fuel generator, direct connection to inertial storage

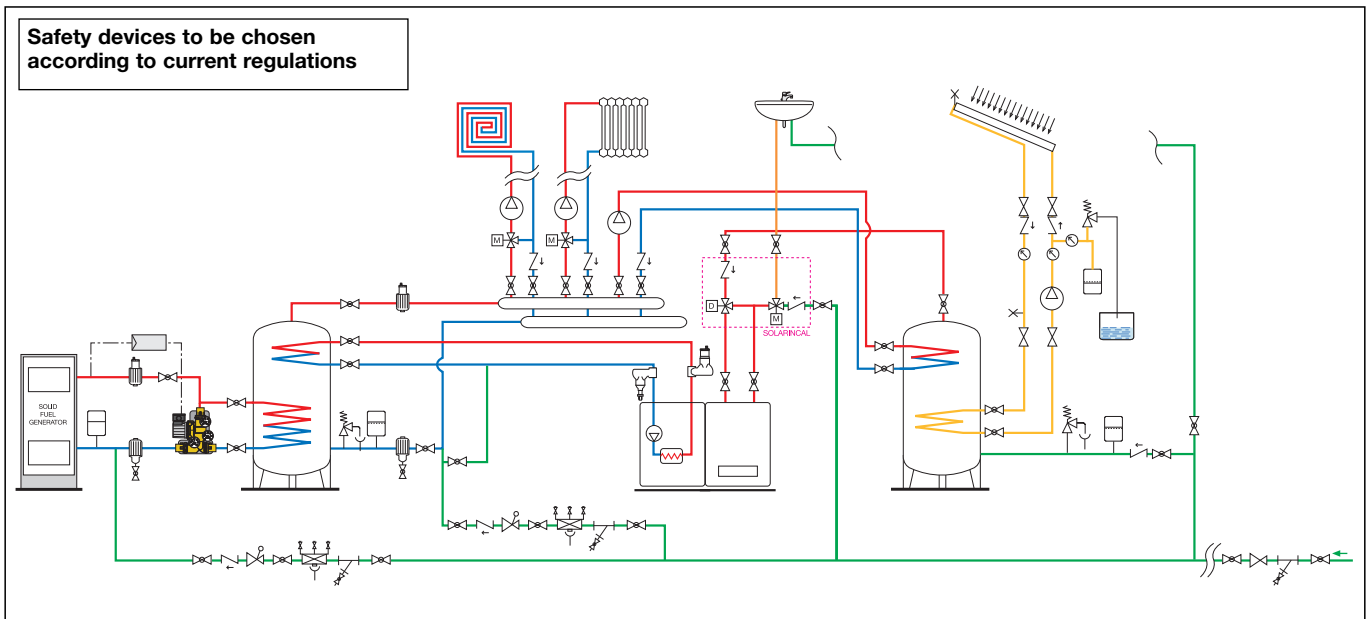

SPECIFICATION SUMMARY

281 series

Anti-condensation recirculation and distribution unit. Size DN 25. Connections 1" (and 1 1/4") F (ISO 228-1) with union. Brass body. Brass obturator locking nut. Brass unions and built-in ball. PSU obturator. Stainless steel spring. PPS clapet valve. EPDM seal elements. Medium water and glycol solutions. Maximum percentage of glycol 50%. Maximum working pressure 10 bar. Working temperature range 5–100°C. Temperature gauge scale 0–120°C. Built-in anti-condensation thermostatic valve: setting temperature 45°C, 55°C, 60°C, 70°C; setting accuracy ±2°C; by-pass complete closing temperature Tset + 10°C. Three-speed pump model RS 4-3 (or high-efficiency pump YONOS PARA 25/6); electric supply 230 V - 50 Hz; maximum ambient humidity 95%; maximum ambient temperature 80°C; protection class IP 44 (IPX4D). Complete with insulation.

We reserve the right to change our products and their relevant technical data, contained in this publication, at any time and without prior notice.



Caleffi S.p.A.
 S.R. 229 n. 25 · 28010 Fontaneto d'Agogna (NO) · Italy
 Tel. +39 0322 8491 · Fax +39 0322 863723
 info@caleffi.com · www.caleffi.com
 © Copyright 2014 Caleffi