

Tempering adjustable valve with knob

5219 series



01194/21 EN

replaces dp 01194/11 GB



Function

The tempering valve is used in systems for the domestic hot water production. Its function is to maintain the temperature of the mixed water supplied to the user constant at the set value when there are variations in the conditions of the hot and cold water at the inlet. The tempering valve also features a thermal shut-off function that operates in the event of a cold water supply failure at the inlet.



Product range

Code 521934/35/36 Tempering valve adjustable with knob size DN 15 (1/2"), DN 20 (3/4"), DN 25 (1")
Code 521914/15/16 Tempering valve adjustable with knob, complete with strainers and check valves at the inlet size DN 15 (1/2"), DN 20 (3/4"), DN 25 (1")

Technical specifications

Materials

Body: dezincification resistant alloy **CR**
 EN 12165 CW724R, chrome plated
 Obturator: PSU
 Springs: stainless steel EN 10270-3 (AISI 302)
 Seals: EPDM
 Knob: ABS

Performance

Adjustment temperature range: 35–65 °C
 Accuracy: ± 2 °C
 Max. working pressure (static): 10 bar
 Max. working pressure (dynamic): 5 bar
 Max. inlet temperature: 90 °C
 Max. inlet pressure ratio (H/C or C/H): 2:1
 Minimum temperature difference between hot water inlet and mixed water outlet, to ensure thermal shut-off function: 15 °C
 Minimum flow rate for stable operation 4 l/min (DN 15 and DN 20)
 6 l/min (DN 25)

Connections: 1/2" - 3/4" - 1" M (ISO 228-1) with union

Dimensions

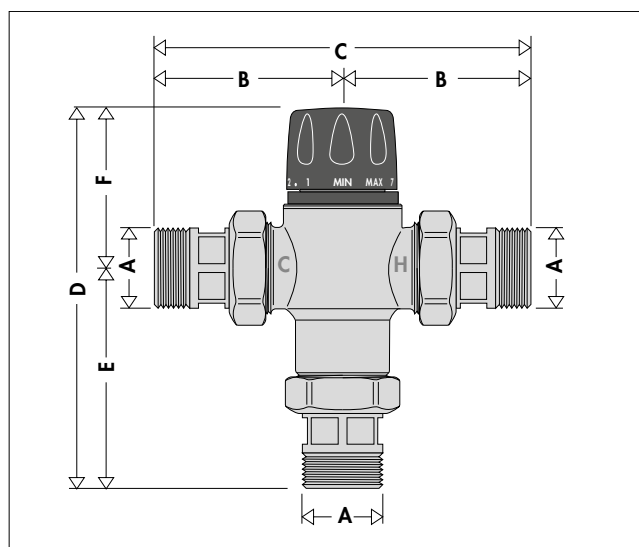

Code	DN	A	B	C	D	E	F	Mass (kg)
521914/34	15	1/2"	62,5	125	136	82	54	0,64
521915/35	20	3/4"	67	134	137	82	55	0,81
521916/36	25	1"	83,5	167	173	100,5	72	1,20

Legionella - point of distribution

According to the most recent legislation and standards, in order to prevent the growth of the dangerous Legionella bacterium in centralised systems producing domestic hot water with storage, the hot water must be stored at a temperature of at least 60°C. At this temperature it is certain that the growth of the bacteria will be totally eliminated.

The adjacent diagram shows the behaviour of Legionella Pneumophila bacteria as the temperature conditions of the water containing the bacteria vary. To ensure correct thermal disinfection, it is necessary to go up to values of at least 60 °C.

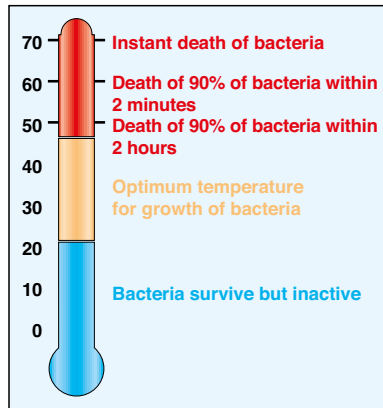

In this type of system, it often happens that the temperature at the storage outlet is unstable and highly variable. This occurs because of multiple operating conditions, in terms of pressure and heat exchange with the primary energy source and the drawn flow rate.

For all these reasons, therefore, a tempering valve must be installed on the hot water storage outlet line, at the inlet point of the distribution system, which is able to:

- reduce the temperature at the point of distribution to a value lower than that of the storage, in a controlled way to make it suitable for domestic use,
- have a temperature adjustment range that makes it possible to perform a thermal disinfection of the system, should this be necessary,
- allow the temperature to be adjusted at the desired value, with a tamper-proof locking system,
- keep the distribution temperature constant despite variations in temperature, inlet pressure and drawn flow rate,
- have a thermal shut-off function that operates in the event of a 0 cold water supply failure at the inlet.

Operating principle

Il miscelatore termostatico miscela l'acqua calda e fredda. In the tempering valve mixes the hot and cold water at the inlet so as to maintain the mixed water at a constant set temperature at the outlet.

A thermostatic element (1) is fully immersed in the mixed water flow (2). It contracts or expands, moving an obturator (3) which controls the passage of hot (4) or cold (5) water at the inlet. If the inlet temperature or pressure changes, the internal element automatically reacts to restore the set temperature at the outlet.

Construction details

Anti-scale materials

The materials used in constructing the tempering valve were selected to eliminate seizing due to limescale deposits. All functional parts are made using a special anti-scale material with low friction coefficient, which ensures that performance is maintained over time.

Thermal shut-off

In the event of accidental cold water supply failure, the obturator shuts off the hot water passage, thus preventing the delivery of mixed water. This performance is guaranteed only when there is a minimum temperature difference between the inlet hot water and the outlet mixed water of 15 °C.

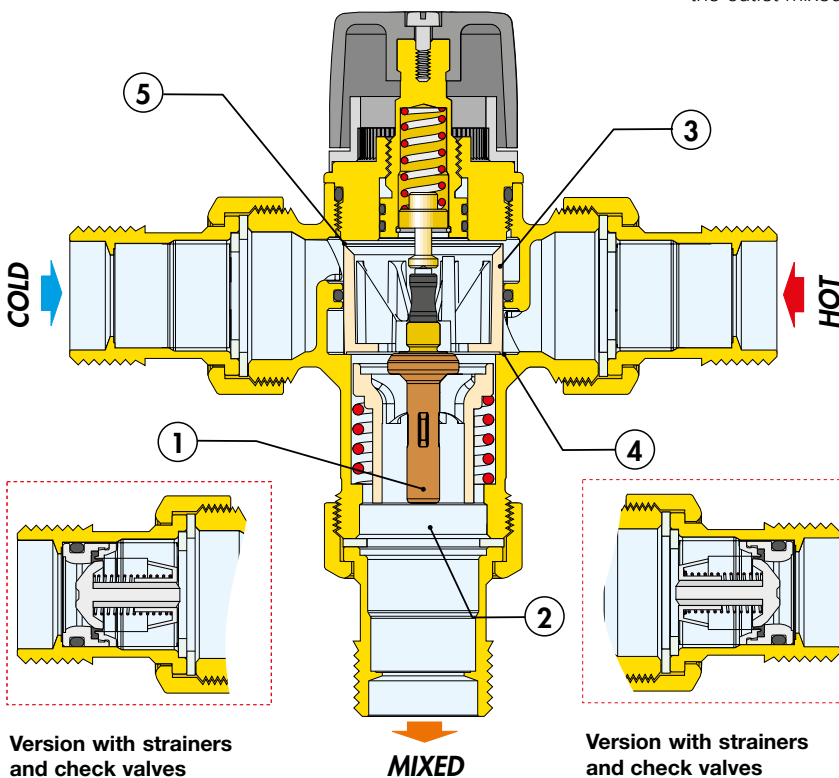

Hydraulic characteristics

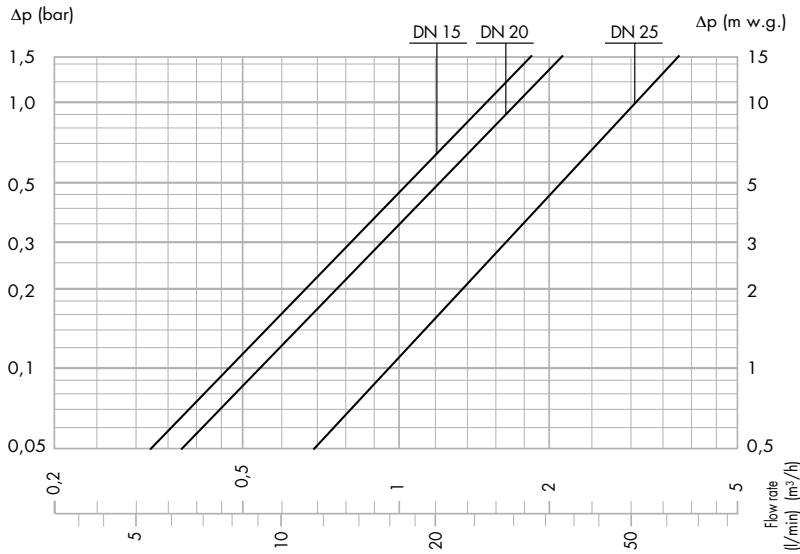

Recommended flow rate values to ensure stable operation with an accuracy of $\pm 2\text{ }^{\circ}\text{C}$

Code	DN	Size	Kv (m³/h)	* $\Delta p = 1,5\text{ bar}$	Minimum (m³/h)	Maximum*
521914/34	15	1/2"	1,5	1/2"	0,24	1,80
521915/35	20	3/4"	1,7	3/4"	0,24	2,00
521916/36	25	1"	3,0	1"	0,36	3,60

Application

The 5219 series tempering valves are used for applications at the point of distribution, to control the temperature of the domestic hot water distributed in the network. To ensure a stable operation, the tempering valve must have a minimum flow rate of 4 l/min (DN 15; DN 20) and 6 l/min (DN 25)

Choice of tempering valve size

Given the design flow rate, taking into account simultaneous use of the domestic appliances, the tempering valve size should be selected by checking the head loss on the provided graph. In this case, it is necessary to check the available pressure, the head loss in the system downstream of the tempering valve and the residual pressure to be guaranteed for user appliances.



Sizing software available at www.caleffi.com
Apple Store and Google play.

Installation

Before installing the tempering valve, the connecting pipes should be flushed to remove any impurities that could impair performance. The installation of strainers of adequate performance at the water inlet from the water supply network is always recommended.

The 5219 series tempering valves must be installed according to the diagrams shown in the instruction sheet or in this leaflet. The 5219 series tempering valves can be installed in any position, horizontally or vertically.

The following indications are on the valve body:

- hot water inlet, indicated by the letter "H" (Hot)
- cold water inlet, indicated by the letter "C" (Cold)
- mixed water outlet, indicated by the word "MIX".

Check valves

In systems with tempering valves, check valves must be installed to prevent undesired backflow. The 5219 series tempering valves are available in versions complete with check valves at the hot and cold water inlets.

Commissioning

In view of the special applications of the tempering valve, it must be commissioned in accordance with current regulations by qualified technicians, using appropriate temperature measurement equipment. We recommend using a digital thermometer for measuring the mixed water temperature.

Temperature adjustment

The temperature is set at the desired value using the control knob with the graduated scale on the valve.

Pos.	Min.	1	2	3	4	5	6	7	Max.
DN 15-DN 20 T(°C)	35	40	45	48	52	56	60	63	65
DN 25 T(°C)	35	38	41	45	50	53	56	60	65

With: $T_{\text{hot}} = 70\text{ }^{\circ}\text{C}$ $T_{\text{cold}} = 15\text{ }^{\circ}\text{C}$

$P_{\text{hot}} = 3\text{ bar}$ $P_{\text{cold}} = 3\text{ bar}$

Locking the setting

Turn the knob onto the required number, unscrew the upper screw, remove the knob and put it back on so that the internal reference couples with the protrusion on the knob holder nut.

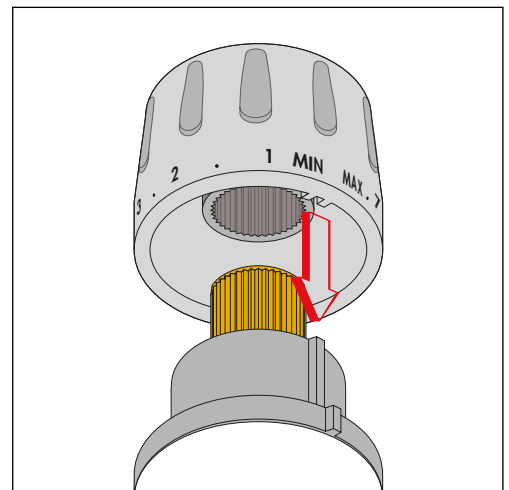

Application diagrams

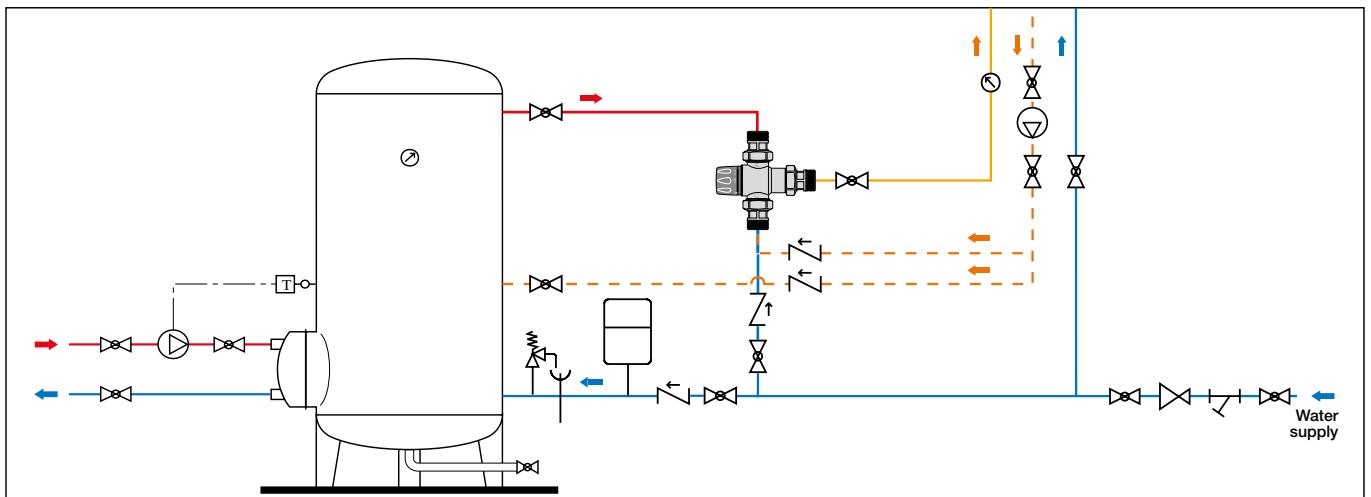
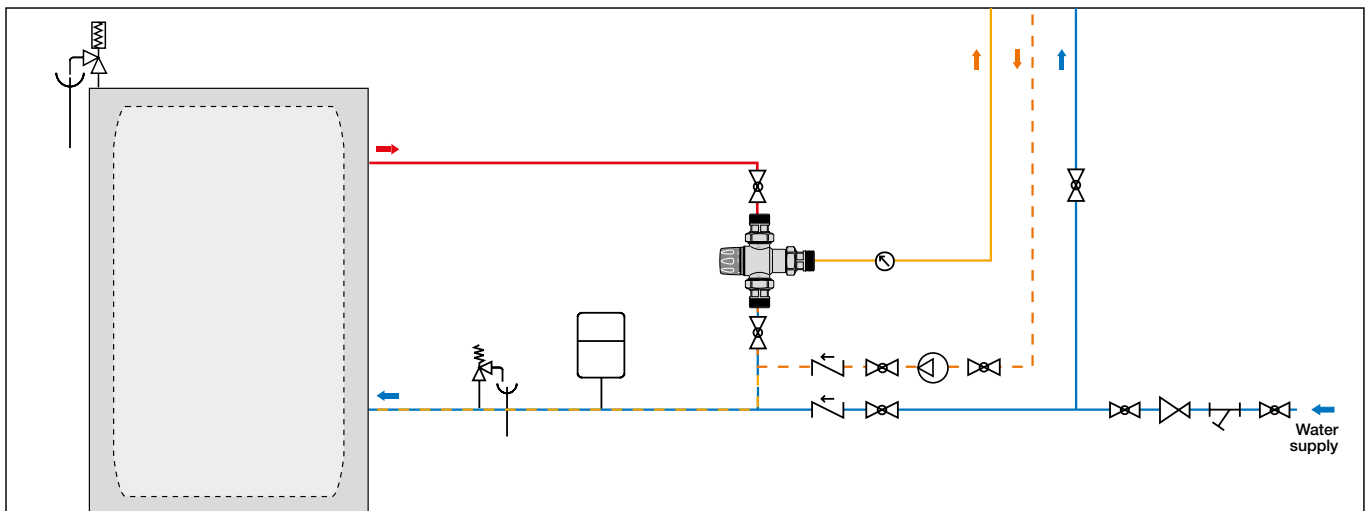
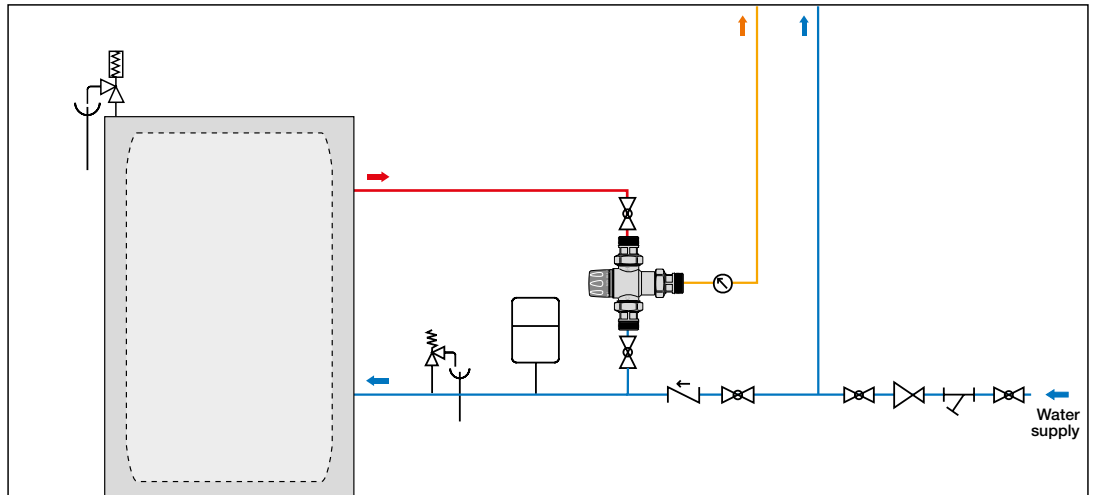
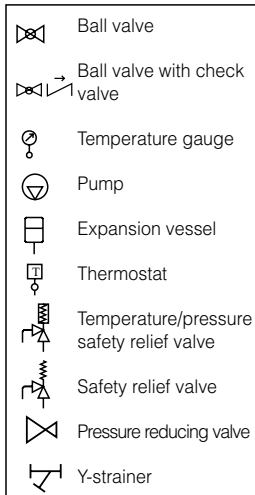

TESTO DI CAPITOLATO

5219 series

Tempering valve adjustable with knob. Size DN 15 (DN 20 or DN 25). Connections 1/2" (3/4" or 1") M (ISO 228-1) with union. Dezincification resistant alloy body. Chrome plated. PSU obturator. Stainless steel springs. EPDM seal elements. ABS control knob. Maximum inlet temperature 90 °C. Adjustment temperature range 35°C to 65°C. Accuracy ± 2 °C. Maximum working pressure (static) 10 bar. Maximum working pressure (dynamic) 5 bar. Maximum inlet pressure ratio (H/C or C/H) 2:1. Equipped with tamper-proof temperature setting lock.

We reserve the right to make changes and improvements to our products and the related technical data in this publication, at any time and without prior notice. The website www.caleffi.com always has the most up-to-date version of the document, which should be used for technical verifications.