

Set point thermostatic regulating unit



01190/18 GB

replaces dp 01190/15 GB

182 series

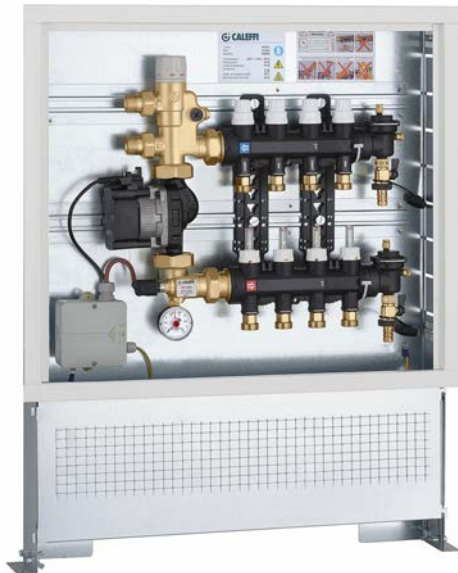

Function

The thermostatic regulating unit is made to be used in radiant panel systems, in combination with distribution manifolds.

The set point regulating unit performs the function of keeping the flow temperature constant, at the set value, for the medium distributed in a low temperature system for floor radiant panels.

In this particular series, the temperature is regulated by a specific hydraulic unit equipped with a thermostatic three-way valve with a built-in sensor.

Reference documentation

- Tech. broch. 01126 Manifolds in composite material specifically designed for radiant panel systems 670 series

Product range

Code 1825.1A2L Pre-assembled set point thermostatic regulating unit with manifolds and box, with UPM3 Auto L 25-70 pump

Technical specifications

Materials

Regulating unit with three-way thermostatic radiator valve

Body: brass EN 1982 CB753S
Headwork: brass EN 12164 CW614N
Obturator: PSU
Seals: EPDM

Flow adapter unit

Body: brass EN 1982 CB753S

Performance

Medium: water, glycol solutions
Max. percentage of glycol: 30%
Adjustment temperature range: 25–55°C
Accuracy: $\pm 2^\circ\text{C}$
Primary inlet max. temperature: 90°C
Maximum working pressure: 600 kPa (6 bar)
Minimum working pressure: 80 kPa (0,8 bar)
Panel manifold differential by-pass setting (optional, code 182000): 25 kPa (2.500 mm w.g.)

LCD digital thermometer scale: 24–48°C
Pressure gauge scale: 0–10 bar

Connections:

- to regulating unit: 3/4" M (ISO 228-1) with union
- panel circuit outlets: 3/4" for coupling with adapter code 675850
- outlet centre distance: 50 mm
- primary circuit connections centre distance: 60 mm

Panel circuit differential by-pass graph

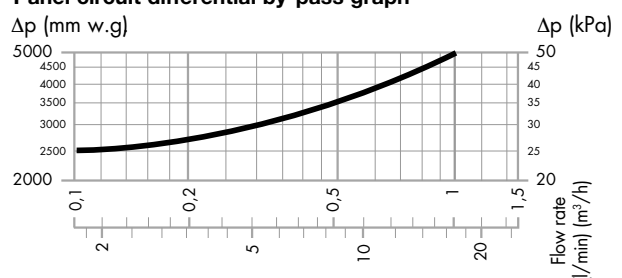

Safety thermostat

Factory setting: 55°C ±3°C
 Protection class: IP 55
 Contact rating: 10 A / 240 V

Electrical connection diagram

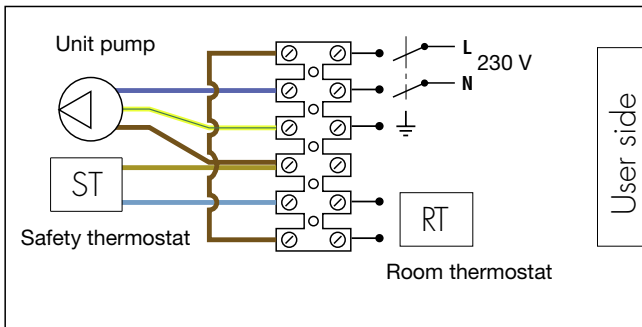

Pump

High-efficiency pump: model UPM3 Auto L 25-70
 Body: cast iron GG 15/20
 Electric supply: 230 V - 50 Hz
 Max. ambient humidity: 95%
 Max. ambient temperature: 70°C
 Protection class: IP 44
 Pump centre distance: 130 mm
 Pump connections: 1 1/2" F (ISO 228-1) with nut

Head available at the regulating unit connections

Tests carried out with constant speed control.

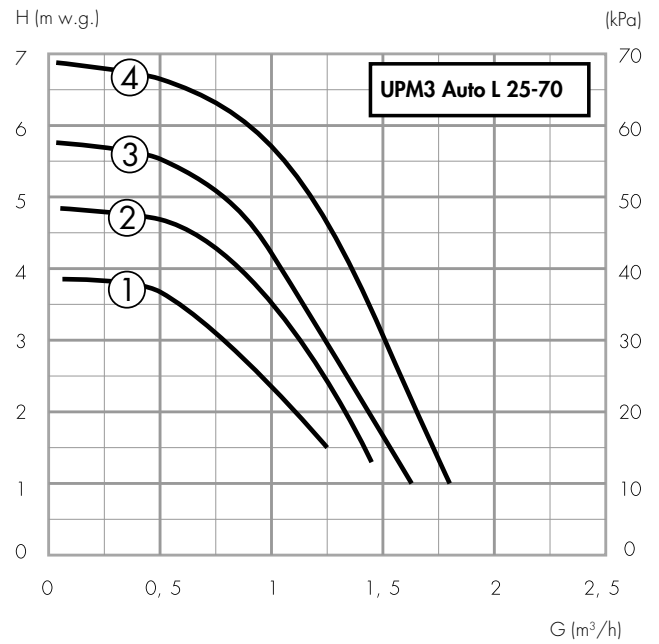

Note:

The pump can operate with constant speed, constant pressure and proportional pressure control, which adapts the performance to the system requirements. For further details, see the installation instruction sheet of the pump supplied in the package.

Dimensions

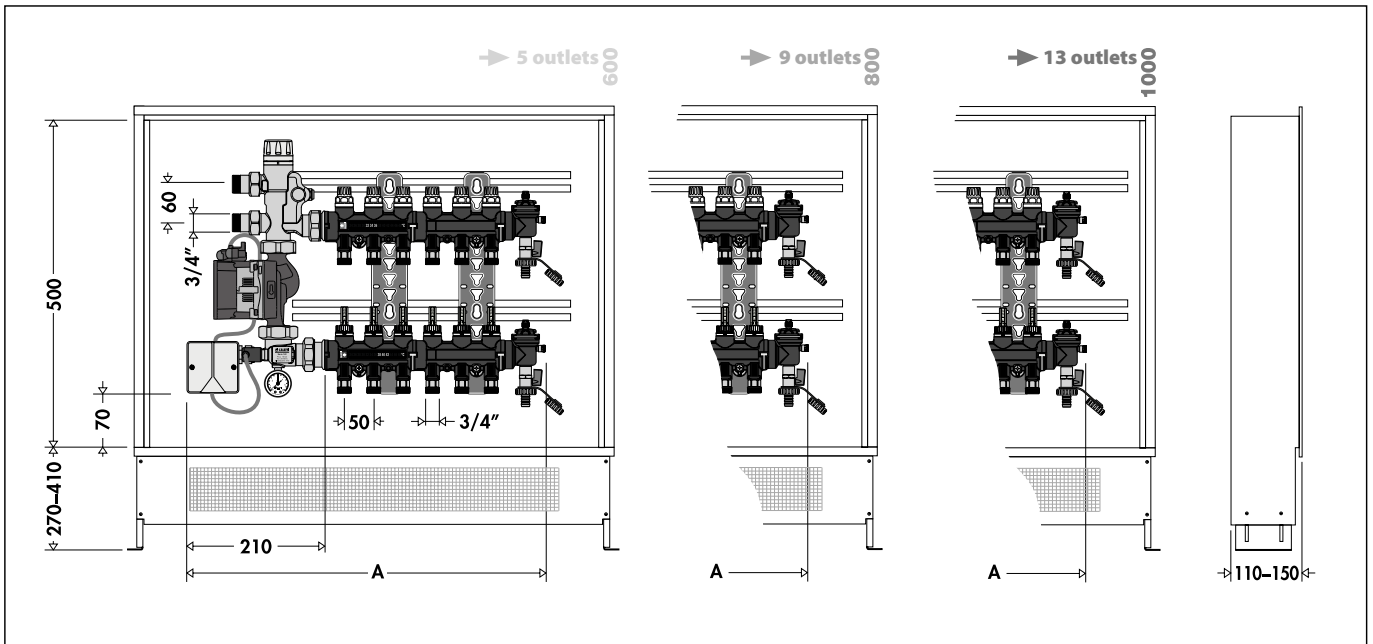

Code	1825C1	1825D1	1825E1	1825F1	1825G1	1825H1	1825I1	1825L1	1825M1	1825N1	1825O1
Panel outlets	3	4	5	6	7	8	9	10	11	12	13
A	435	485	535	585	635	685	735	785	835	885	935

Characteristic components

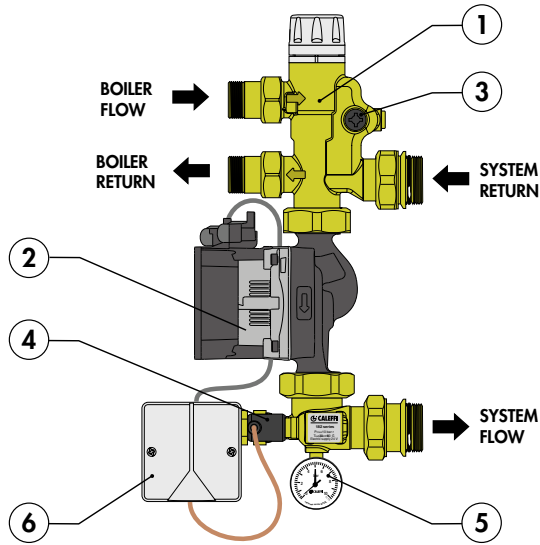

Return manifold equipped with shut-off valves.

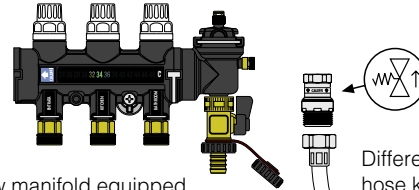

Flow manifold equipped with flow meters and balancing valves.

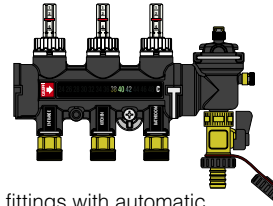

End fittings with automatic air vent and fill/drain cock.

Differential by-pass hose kit (optional, code 182000)

- | | |
|--|---|
| <ol style="list-style-type: none"> 1. Thermostatic three-way mixing valve with built-in sensor 2. High-efficiency pump UPM3 Auto L 25-70 3. Fitted for adjustable drain valve | <ol style="list-style-type: none"> 4. Safety thermostat 5. Pressure gauge 6. Electrical wiring box |
|--|---|

Hydraulic diagram

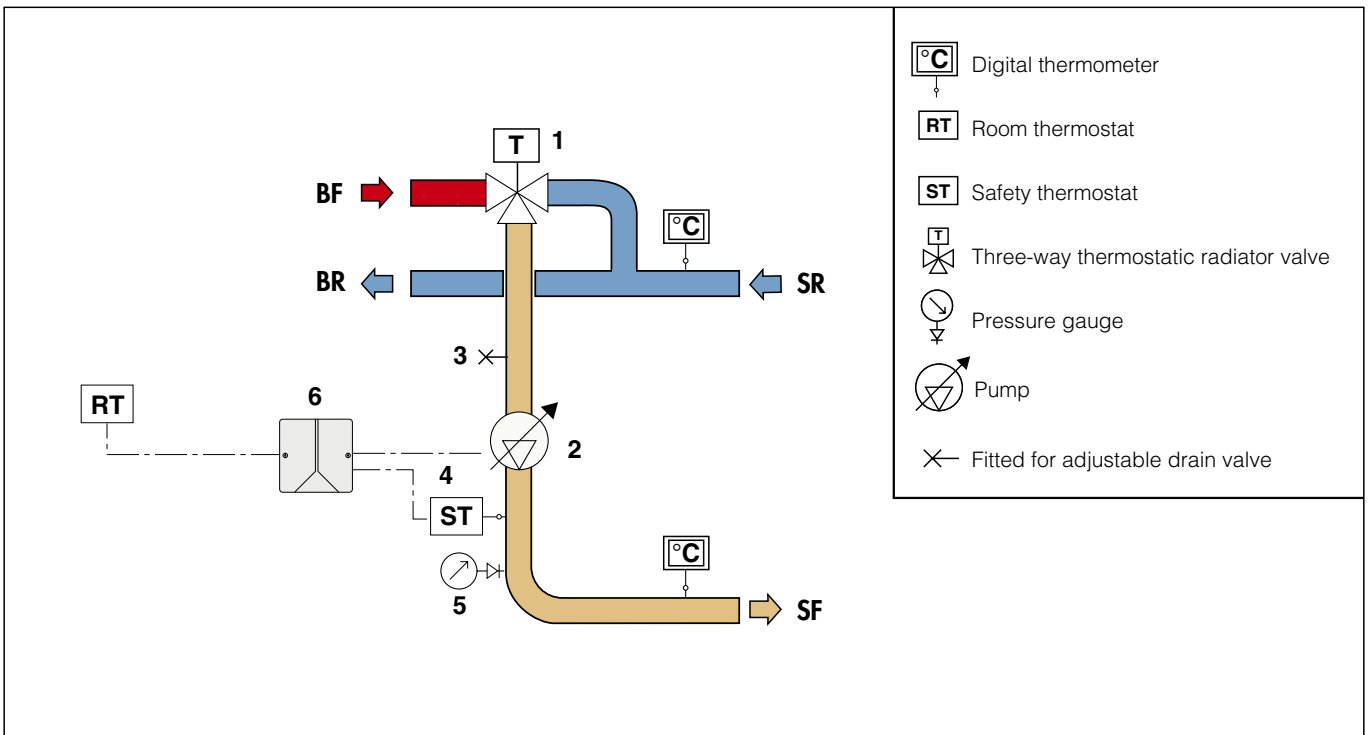

Operating principle

The regulator element inside the thermostatic three-way valve consists of a temperature sensor (1) fully immersed in the mixed water outlet chamber. By expanding and contracting, it continuously ensures a correct proportioning of hot water, coming from the boiler, and water returning from the panel circuit. The water intake is regulated by a shaped obturator (2) that slides inside a special cylinder placed between the hot water flow (3) and the water returning from the circuit (4).

Even if the thermal load of the secondary circuit or the inlet temperature from the boiler changes, the mixing valve automatically adjusts the flow rates until it obtains the set temperature.

Construction details

Regulating unit body

The valve body, containing the temperature regulating device, is made out of a single casting with connections to the primary and secondary circuits. A specific internal channel carries the system return medium to the regulating valve, making it possible to build a compact unit that is easy to connect.

Reduced head losses

The three-way mixing valve is equipped with a special obturator that acts on calibrated water orifices. This ensures a high flow rate and a compact size, while maintaining accurate temperature control.

Anti-seizing materials

The materials used for the mixing valve construction eliminate potential seizing due to scale. All functional parts, such as the obturator, valve seats and guides, have been made using a special material with low friction coefficient, which ensures product performance over time.

Low-inertia thermostatic sensor

The temperature-sensitive element, the “actuator” of the three-way thermostatic valve, has low thermal inertia; in this way it can react quickly to changes in the conditions of inlet pressure and temperature, shortening the valve response time to the changes in thermal load.

Temperature adjustment and locking

The control knob is used to adjust the temperature in a full turn (360°) between min. and max. It also has a tamper-proof system for locking the temperature at the set value.

Adjustment locking

Turn the knob onto the required number, unscrew the upper screw, remove the knob and put it back on so that the internal reference couples with the protrusion on the knob holder nut.

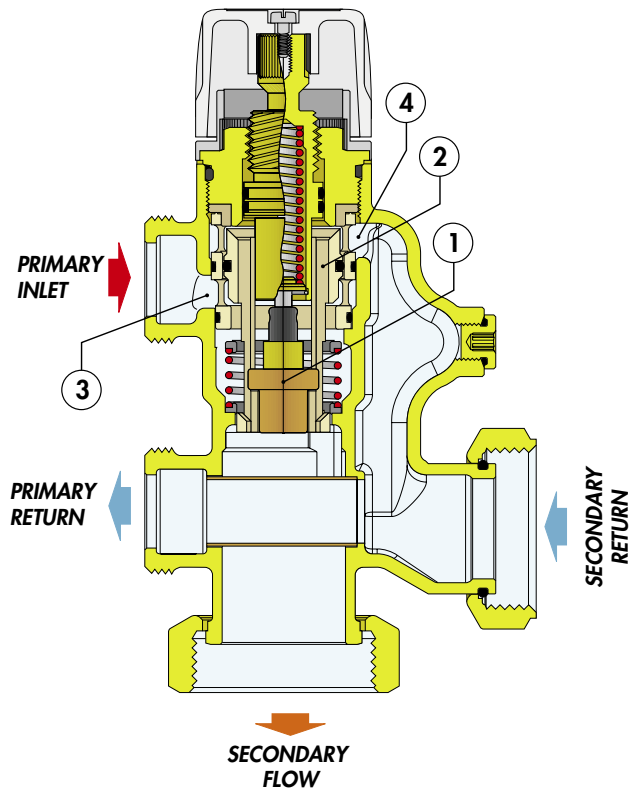
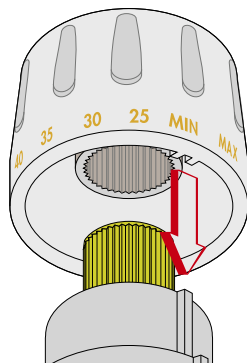

Flow unit

The flow unit is made out of a single casting with the necessary ports to connect with the functional components such as the safety thermostat and the pressure gauge.

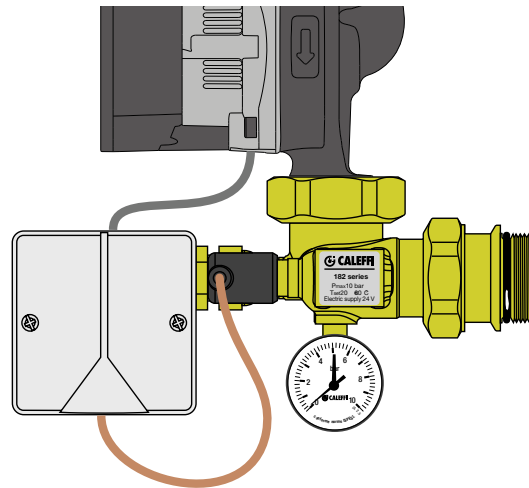

Safety thermostat

We recommend the safety thermostat is connected to the heat generator so that the electric supply is cut off when the triggering temperature is reached. To do so, connect the two safety thermostat wires directly to the generator and create an electrical jumper between the two contacts on the terminal board for unit 182, previously connected to the safety thermostat.

Application diagrams

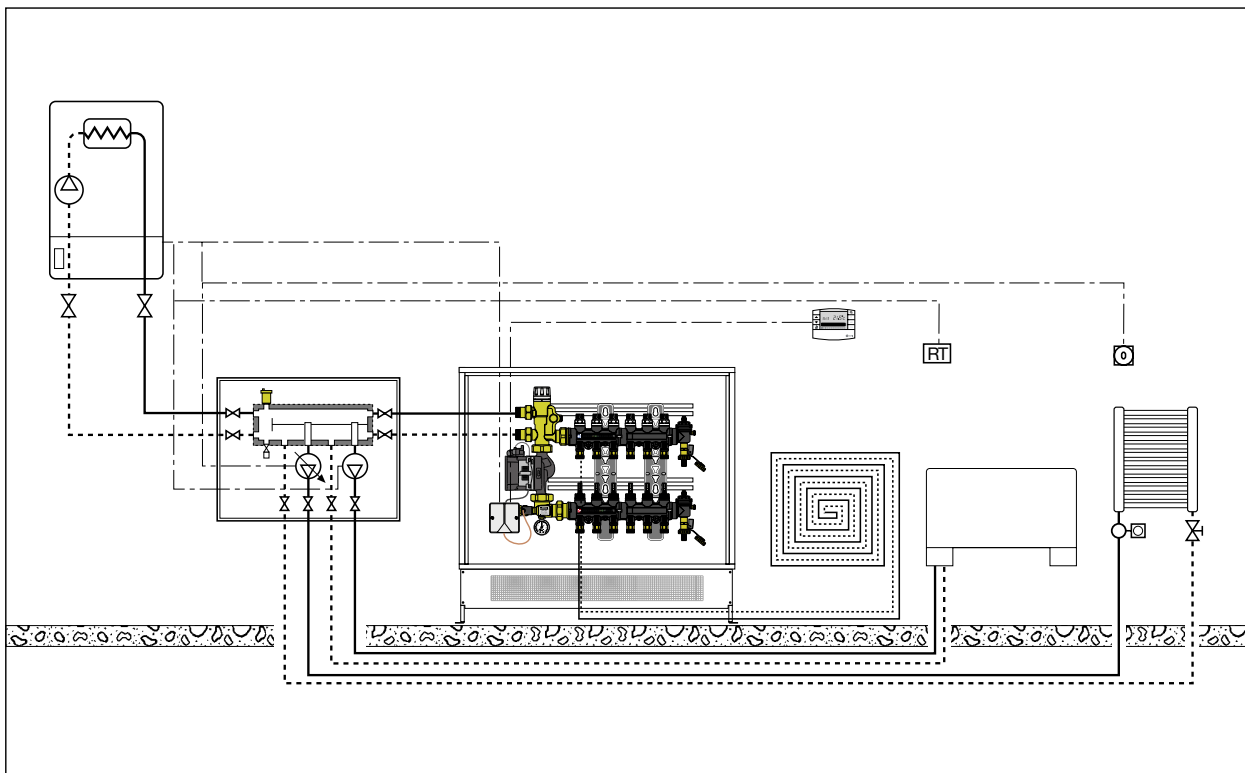
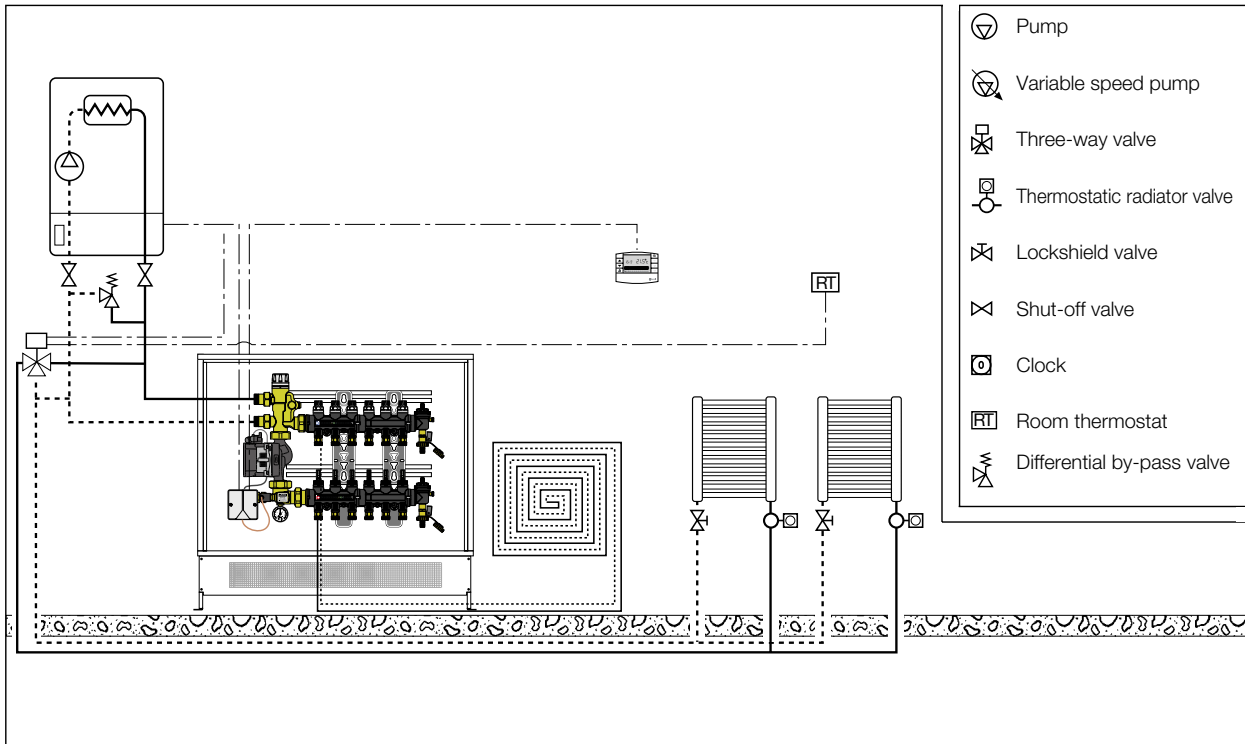

SPECIFICATION SUMMARY

182 series

Set point thermostatic regulating unit. Connections to the regulating unit 3/4" M (ISO 228-1) with union. Panel circuit outlet connections 3/4" for coupling with adapter code 675850. Medium water and glycol solutions; max. percentage of glycol 30%. Regulating temperature range 25–55°C. Maximum temperature at primary circuit inlet 90°C. Maximum working pressure 600 kPa (6 bar). Minimum working pressure 80 kPa (0,8 bar). Panel manifold differential by-pass (optional, code 182000) setting 25 kPa. LCD thermometer scale 24–48°C. Pressure gauge scale 0–10 bar.

Complete with: flow manifold for panel system with 3 outlets (from 3 to 13) with PA66GF body, flow rate regulating valve with flow meter with a scale of 1–4 l/min; return manifold for panel system with 3 outlets (from 3 to 13) with PA66GF body, shut-off valve. Regulating unit with three-way thermostatic valve with brass body and headwork, PSU obturator and EPDM seals. Flow adapter unit with brass body. Electric supply 230 V - 50 Hz. Safety thermostat: factory setting 55°C ± 3°C, protection class IP 55, contact rating 10 A / 240 V. Pump UPM3 Auto L 25-70, protection class IP 44. Supplied preassembled in painted sheet metal box. Closure with a push-fit clamp. Depth adjustable from 110 to 150 mm, including floor supports adjustable in height from 270 to 410 mm.

We reserve the right to make changes and improvements to the products and related data in this publication, at any time and without prior notice.