

# HydroCal™ Combination Air, Dirt and Hydraulic Separator

## 549 and NA549 series



### Function

The Caleffi HydroCal™ combination air, dirt and hydraulic separator is a device that combines high performance air and dirt removal with hydraulic separation. Primary and secondary circuits connected to it become hydraulically decoupled thus eliminating pump conflict.

A proven, time tested stainless steel internal coalescing element continuously and automatically eliminates all entrained air, including microbubbles, in the system. Air discharge capacity is very high. Over time, dirt particles as tiny as 5 microns are captured and collected away from the flow stream.

The 3 in 1 high performance functionality of the HydroCal™ saves system installation and maintenance cost as there is no need to include separate air and dirt separators. It can be used on either hot or chilled water systems.

### Product range

- 549 series HydroCal™ air, dirt and hydraulic separator in steel with flanged connections, drain and insulation \_\_\_\_\_ connections 2" - 4" ANSI
- NA549 series HydroCal™ air, dirt and hydraulic separator in steel with flanged connections, drain and insulation, \_\_\_\_\_ connections 2" - 4" ANSI  
ASME and CRN
- NA549 series HydroCal™ air, dirt and hydraulic separator in steel with flanged connections and drain, ASME and CRN \_\_\_\_\_ connections 6" & 8" ANSI

### Technical specification

- Connections: - Flanged: 2"–8" ANSI B16.5 150 CLASS RF
- Drain valve: 2"–6": 1-1/4" NPT female  
8": 2" NPT female
- Materials: - Separator body: epoxy resin painted steel body
- Air vent body: brass
- Shut-off and drain valve body: brass
- Internal element: stainless steel
- Air vent seal: VITON
- Air vent float: stainless steel

- Suitable fluids: water and non-hazardous glycol solutions up to 50%
- Max. operating pressure: 150 psi (10 bar)
- Temperature range: - with insulation 32–220°F (0 - 105°C)
- without insulation 32–250°F (0 - 120°C)
- Particle separation capacity: to 5 µm

### Agency Approval

Series NA549 is designed and built in accordance with Section VIII, Division 1 of the ASME Boiler and Pressure Vessel Code and tagged and registered with the National Board of Boiler and Pressure Vessel Inspector, and CRN registered.

### Technical specifications of insulation

#### Inner part

- Material: rigid closed cell expanded polyurethane foam
- Thickness: 2 3/8" (60 mm)
- Density: 3 lb/ft³ (45 kg/m³)
- Conductivity (ISO 2581): 0.16 BTU-in/hr-ft²·°F (0.023 W/(m·K))
- Temperature range: 32–220°F (0–105°C)

#### Outer part

- Material: Embossed aluminium
- Thickness: 7-mil (0.70 mm)
- Fire resistance (DIN 4102): Class 1

#### Head covers

- Heat formed material: PS

### Dimensions

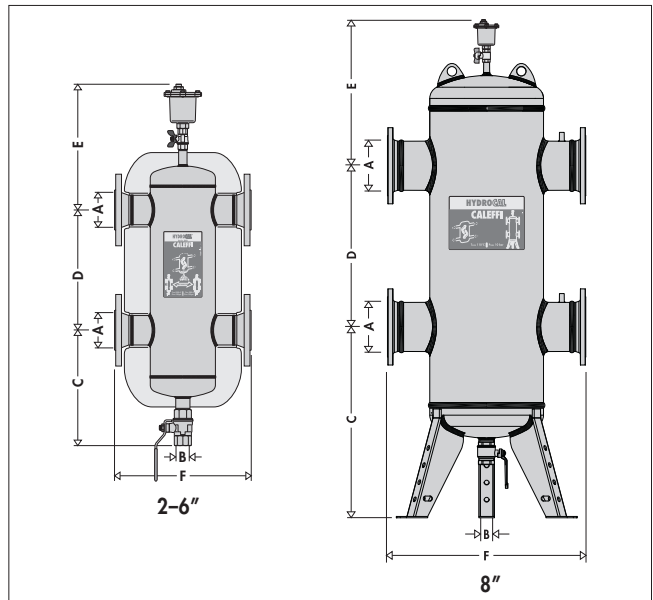

Code	A	B	C	D	E	F	Weight (lb)	Flow (gpm)	Vol. (gal)
549052A	2"	1 1/4"	13"	13"	15"	14"	73	37	4.0
549062A	2 1/2"	1 1/4"	13"	13"	15"	14"	79	62	4.0
549082A	3"	1 1/4"	15"	17 3/4"	17"	18"	108	94	8.0
549102A	4"	1 1/4"	15"	17 3/4"	17"	18"	117	148	8.0
NA549150A*	6"	1 1/4"	15"	22"	19"	25"	231	376	23.2
NA549200A*	8"	2"	33 7/8"	39 3/8"	27 1/2"	35 1/2"	520	625	95.0

\* without insulation

NA prefix indicates ASME tagged and registered with the National Board of Boiler and Pressure Vessel Inspectors and CRN registered.

Add NA prefix to 2" to 4" flanged connection for ASME approved, CRN registered.

## Operating principle

### Hydraulic separation

When a single system contains a primary production circuit, with its own pump, and a secondary user circuit, with one or more distribution pumps, operating conditions may arise in the system whereby the pumps interact, creating abnormal variations in circuit flow rates and pressures. The hydraulic separator creates a zone with a low pressure loss, which enables the primary and secondary circuits connected to it to be hydraulically independent of each other; **the flow in one circuit does not affect flow in the other.**

In this case, the flow rate in the respective circuits depends exclusively on the flow rate characteristics of the circuit pumps, preventing reciprocal influence caused by connection in series. Therefore, using a device with these characteristics means that the flow in the secondary circuit only circulates when the relevant pump is on, permitting the system to meet the specific load requirements at that time.

When the secondary pump is off, there is no circulation in the secondary circuit; the whole flow rate produced by the primary pump is by-passed through the separator. With the hydraulic separator, it is therefore possible to have a primary production circuit with a constant flow rate and a secondary distribution circuit with a variable flow rate; these operating conditions are typical of modern heating and cooling systems.

Three possible hydraulic balance situations are shown below.

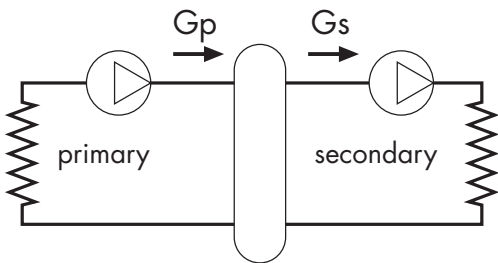

### Microbubble air separation

The HydroCal's internal element (1) creates the whirling movement required to facilitate the release of microbubbles and their adhesion to the internal element surfaces. The bubbles, fusing with each other, increase in size until the hydrostatic thrust overcomes the adhesion force to the mesh. They rise towards the top of the unit from which they are released through a float-operated automatic air vent.

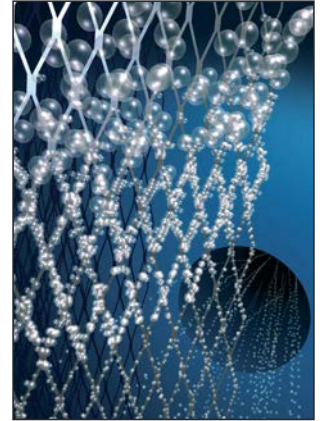

### Microparticle dirt separation

Impurities in the fluid upon striking the surfaces of the HydroCal's internal element (1), get separated and drop to the bottom of the body (2) where they collect.

In addition, the large internal volume of HydroCal™ slows down the flow speed of the fluid thus helping, by gravity, to separate the particles it contains.

The collected impurities are discharged, by opening the drain valve (3) with the handle (4), even with the system operating.

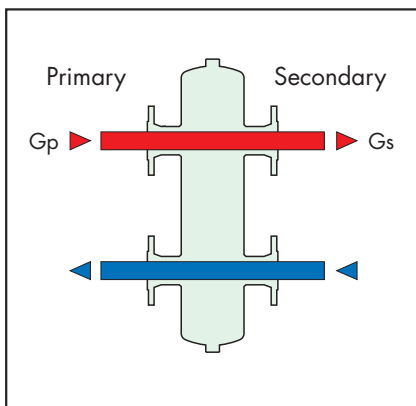
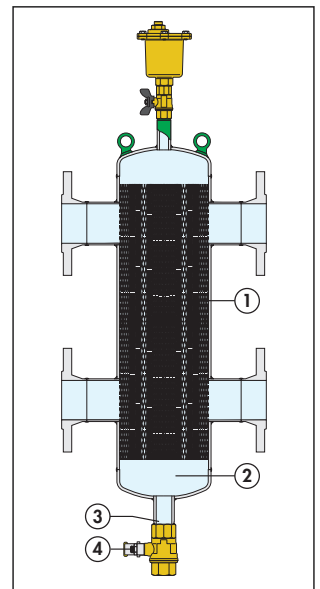

$$G_{\text{primary}} = G_{\text{secondary}}$$

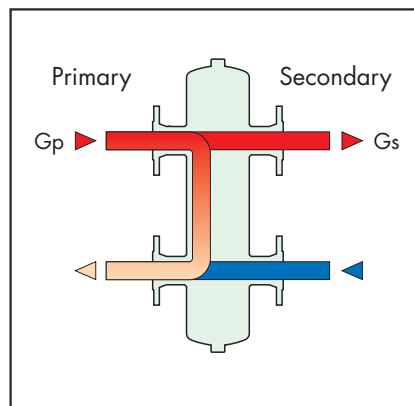

$$G_{\text{primary}} > G_{\text{secondary}}$$

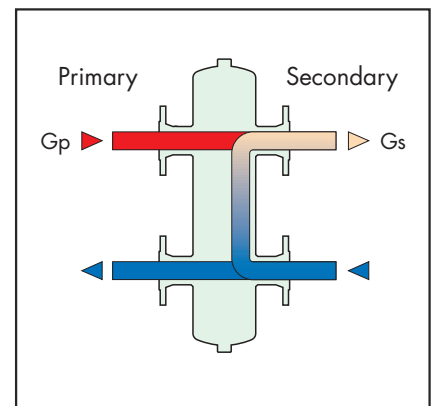

$$G_{\text{primary}} < G_{\text{secondary}}$$

## Construction details

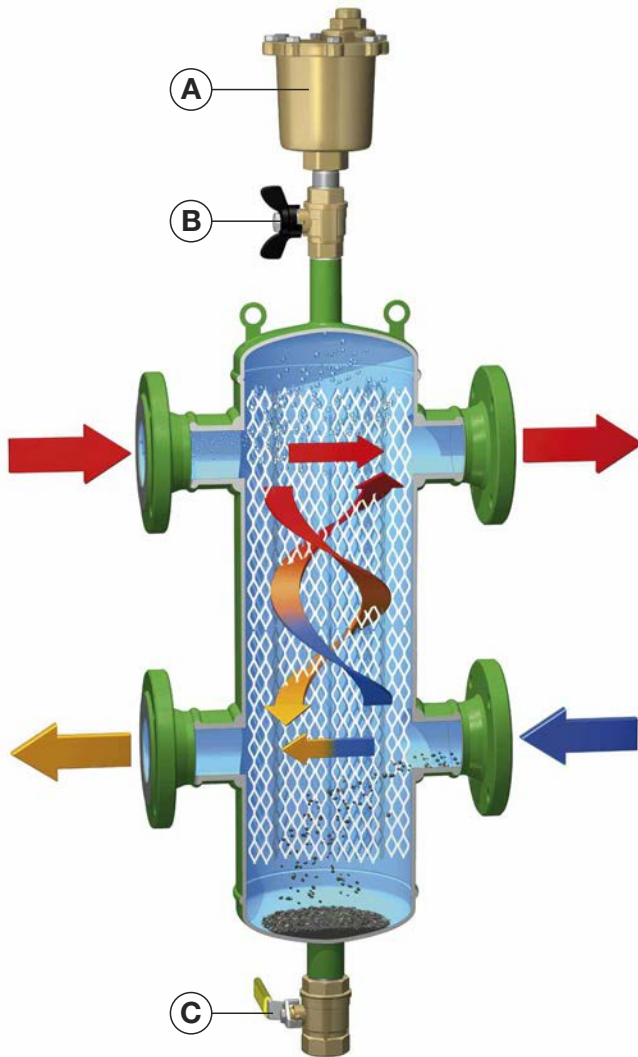

### Isolating the air vent valve

The air vent (A), replacement part number 501502A, is isolated manually, using a shut-off ball valve (B), replacement part number NA39589.

### Dirt removing element

The HydroCal™ dirt removing element separates and collects any impurities present in the system.

These impurities are removed by the drain valve (C) replacement part number NA39588 for connection sizes 2"-6"; NA59600 for connection size 8", which can be connected to a discharge pipe, at the bottom of the separator.

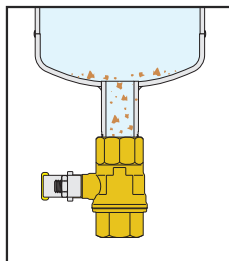

## Insulation

The HydroCal™ is available complete with a hot preformed insulation shell. In the flanged series, sizes 2" to 4", the insulation is made of a shell in expanded polyurethane foam covered with an aluminium layer. This insulation ensures not only perfect heat insulation but also the tightness required to prevent atmospheric water vapors from entering the unit. For these reasons, this type of insulation can also be used in cooling water circuits, as it prevents the formation of condensate on the surface of the separator body. NOTE: Insulation shells are not available for sizes 6" and 8".

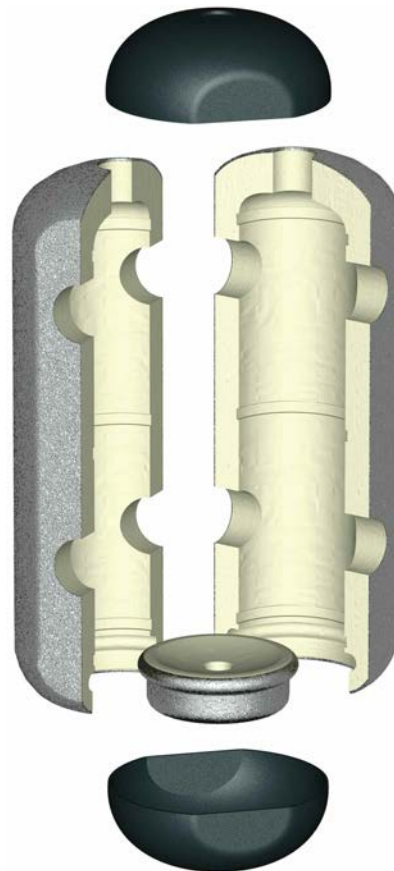

## Hydraulic characteristics

The HydroCal™ should be sized according to the maximum flow rate value at the inlet. The selected design value is the primary circuit flow rate, or secondary circuit flow rate, whichever is largest.

### Flanged connections

Size	2"	2 1/2"	3"	4"	6"	8"
gpm	37	62	94	148	376	625
m³/h	8.5	18	14	22	86	142
l/s	2.3	4.0	6.0	9.3	23.7	40

## Application diagram

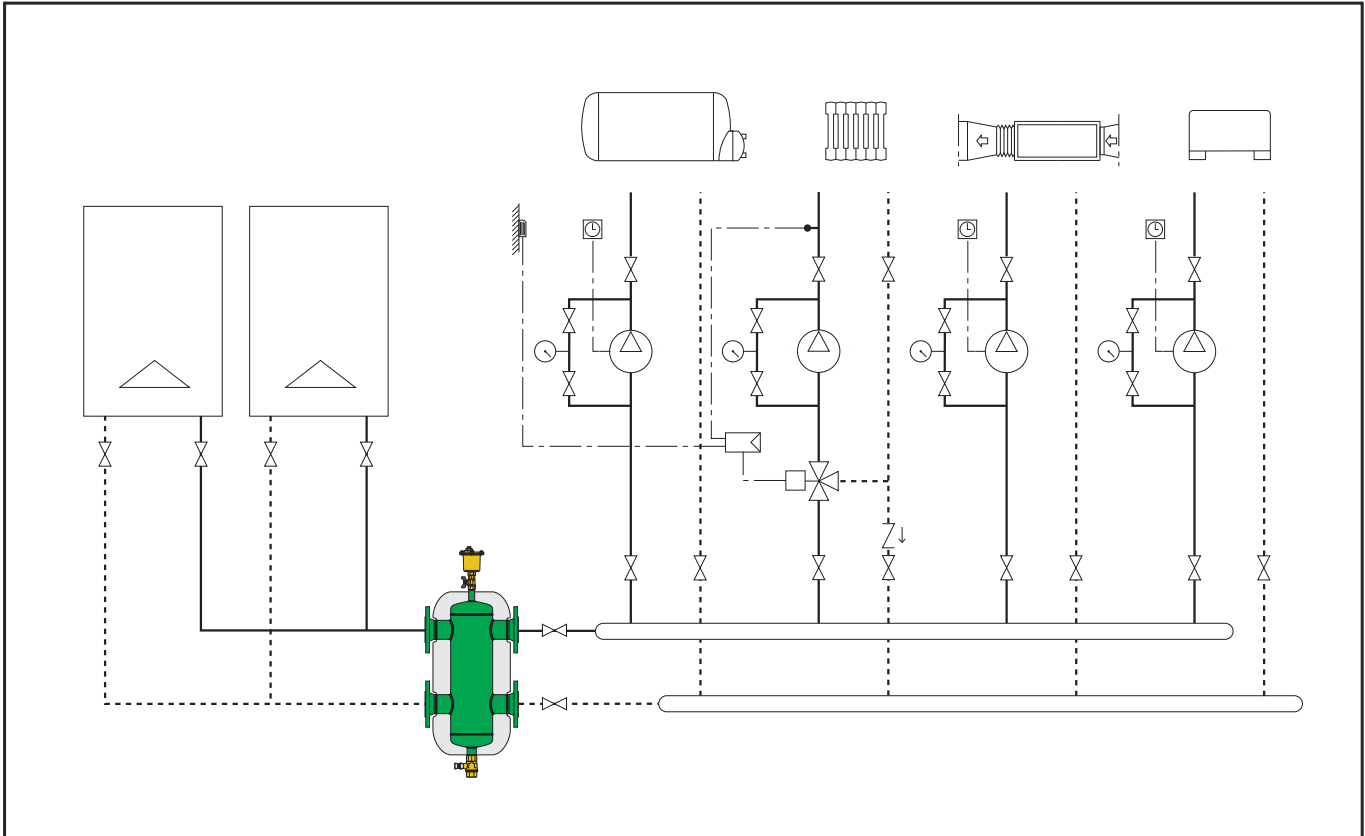

## SPECIFICATION SUMMARIES

### HydroCal™ 549 series

Combination Air, Dirt and Hydraulic Separator. ANSI B16.5 CLASS 150 RF Flanged connections 2", 2 1/2", 3", 4" and 6". Epoxy resin painted steel body. Temperature range of 32 - 250°F (0 -120°C) with insulation. Glycol maximum 50%. Max. working pressure 150 psi (10 bar). Supplied with: Automatic air vent with 3/4" NPT Female outlet connection and brass body. Brass body 3/4" NPT Female shut-off ball valve for air vent. Drain ball valve brass body with 1 1/4" NPT Female connection. Rigid closed cell expanded polyurethane foam shell insulation with external embossed aluminium cover for 2, 2-1/2, 3, and 4 inch sizes.

### HydroCal™ NA549 series

Combination Air, Dirt and Hydraulic Separator. ANSI B16.5 CLASS 150 RF Flanged connections 2", 2 1/2", 3", 4", 6" and 8". Epoxy resin painted steel body. Temperature range of 32 - 250°F (0 -120°C) with insulation. Max. working pressure 150 psi (10 bar). Supplied with: Automatic air vent with 3/4" NPT Female outlet connection and brass body. Brass body 3/4" NPT Female shut-off ball valve for air vent. Drain ball valve brass body with 1 1/4" NPT Female connection for separator sizes 2" - 6"; 2" NPT female connections for separator size 8". Rigid closed cell expanded polyurethane foam shell insulation with external embossed aluminium cover for 2, 2-1/2, 3, and 4 inch sizes. The separator is designed and built in accordance Section VIII, Division 1 of the ASME Boiler and Pressure Vessel Code and tagged and registered with the National Board of Boiler and Pressure Vessel Inspector, and CRN registered.

*We reserve the right to change our products and their relevant technical data, contained in this publication, at any time and without prior notice.*



Caleffi North America, Inc.  
3883 West Milwaukee Road / Milwaukee, WI 53208  
Tel: 414.238.2360 / Fax: 414.238.2366  
www.caleffi.us  
© Copyright 2012 Caleffi