

Adjustable anti-scald thermostatic mixing valve for solar thermal systems

2527 series



Function

The thermostatic mixing valve is used in solar thermal systems for the production of domestic hot water.

It is designed to maintain the set temperature of the mixed water supplied to the user when there are variations in the temperature and pressure conditions of the incoming hot and cold water or in the flow rate.

It is also fitted with an anti-scald safety function, which immediately shuts off the hot water flow in case of a failure in the cold water supply at the inlet.

This particular series of mixing valves can function continuously at the high temperatures of the incoming hot water from the solar storage tank.



Product range

2527 series Adjustable anti-scald thermostatic mixing valve for solar thermal systems.

Complete with strainers and check valves at the inlets _____ sizes DN 15 (1/2") and DN 20 (3/4")

Technical specifications

Materials

Body:	brass EN 12165 CW617N, chrome plated
Obturator:	PSU
Springs:	stainless steel EN 10270-3 (AISI 302)
Seal components:	EPDM
Control Knob:	ABS

Performance

Adjustment range:	35–55 °C
Accuracy:	± 2 °C
Max. working pressure (static):	10 bar
Max. working pressure (dynamic):	5 bar
Max. inlet temperature:	100 °C
Max. inlet pressure ratio (H/C or C/H):	2:1
Minimum temperature difference between the inlet hot water and the outlet mixed water to ensure anti-scald performance:	10 °C
Min. flow rate for stable operation:	4 l/min
Performance to standards:	NF 079 doc.8, EN 15092, EN 1111, EN 1287

Connections: 1/2" and 3/4" M (ISO 228-1) with union

Dimensions

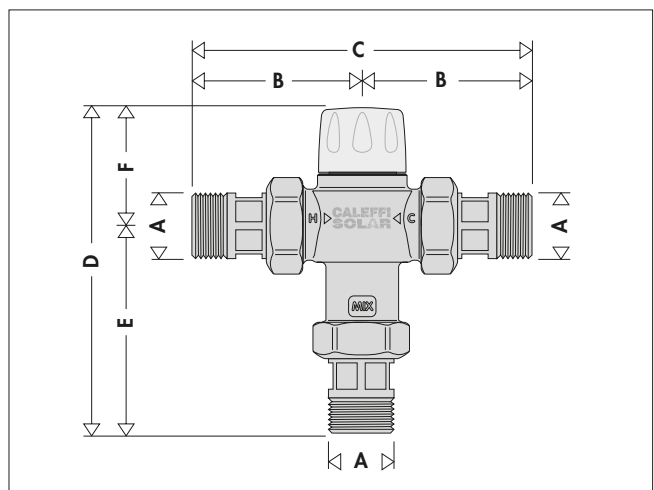

Codice	DN	A	B	C	D	E	F	Mass (kg)
252714	15	1/2"	62,5	125	126,5	81,5	45	0,58
252713	20	3/4"	67	134	127	82	45	0,81

High temperature solar systems

In solar thermal systems with natural circulation in the primary circuit and a water storage with heating jacket, the temperature of the domestic water in the storage can vary considerably depending on the degree of solar radiation and can reach very high temperatures over long periods. In summer, and if there is little water usage, the hot water at the storage outlet can actually reach temperatures around 98 °C before the temperature and pressure safety relief valves are actuated. At these temperatures, the hot water cannot be used directly, because of the danger of scalding for users. Water temperatures over 50 °C can cause burns very quickly. For example, at 55 °C, partial burn occurs in about 30 seconds, whereas at 60 °C partial burn occurs in about 5 seconds. It is therefore necessary to use a thermostatic mixing valve able to:

- Reduce the temperature of the water distributed throughout the domestic water system to a value lower than that in the storage and suitable for the end user. For reasons of safety, it is recommended to set the temperature of the mixed water distributed to the users to values no higher than 50 °C.
- Keep mixed water temperature constant despite variations in inlet temperature and pressure.
- Continue functioning over time without any loss in performance and without problems due to the continuously high temperature of the incoming water.
- Enable the high temperature water in the tank to last longer, by distributing it to the user circuit at a reduced temperature.
- Have an anti-scald safety function in case of failure of the cold water supply.

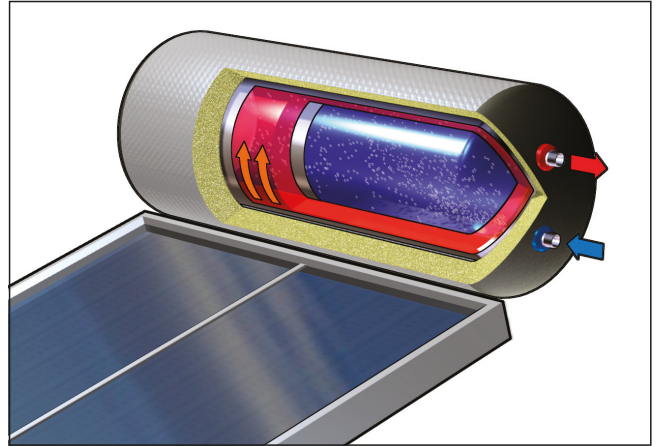

Exposure time to cause partial burns

Temperature	Adults	Children 0-5 years
70 °C	1 s	--
65 °C	2 s	0,5 s
60 °C	5 s	1 s
55 °C	30 s	10 s
50 °C	5 min	2,5 min

Operating principle

The thermostatic mixing valve mixes the hot and cold water at the inlet so as to maintain the mixed water at a constant set temperature at the outlet. A thermostatic element is fully immersed in the mixed water outlet passage. It contracts or expands, moving an obturator which controls the passage of hot or cold water at the inlet. If there are changes in the inlet temperature or pressure, the internal element automatically reacts to restore the set temperature at the outlet.

Construction details

High resistance to temperature

Internal control components are designed to maintain constant the mixing valve performance with inlet hot water temperatures up to 100°C, in continuous operation.

Anti-scale materials

The materials used in constructing the mixing valve were selected to eliminate seizing due to limescale deposits. All functional parts have been made using a special anti-scale material with low friction coefficient, which ensures over time performance.

Anti-scald safety function

As a safety measure, in case of failure of the cold water supply, the valve immediately shuts off the flow of the hot water. This prevents dangerous burns. This performance is guaranteed if there is a minimum temperature difference between the inlet hot water and the outlet mixed water of 10°C. Also in case of failure of the hot water supply, the valve shuts off the cold water port and thus the outlet mixed water to prevent dangerous thermal shocks.

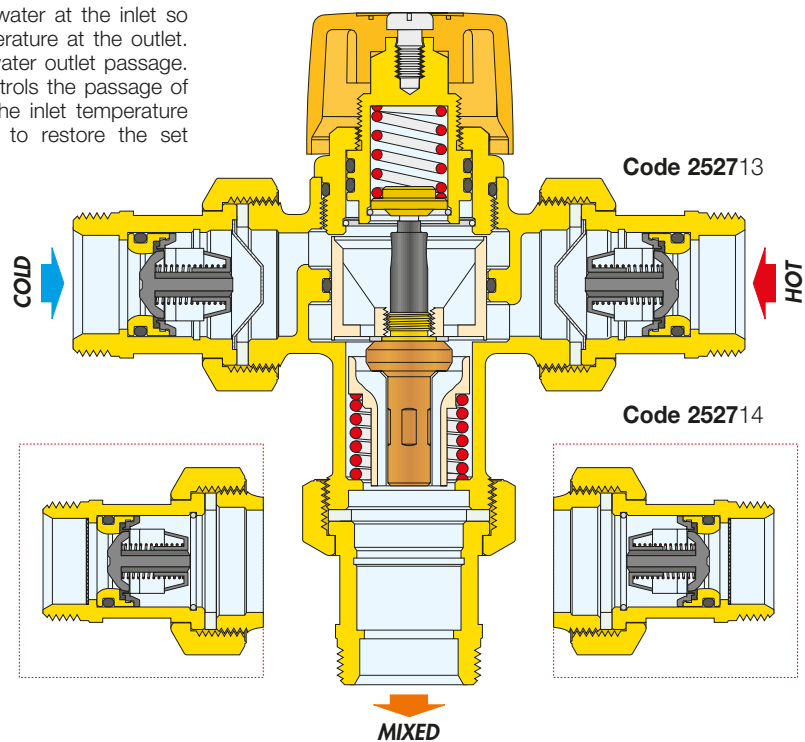

Hydraulic characteristics

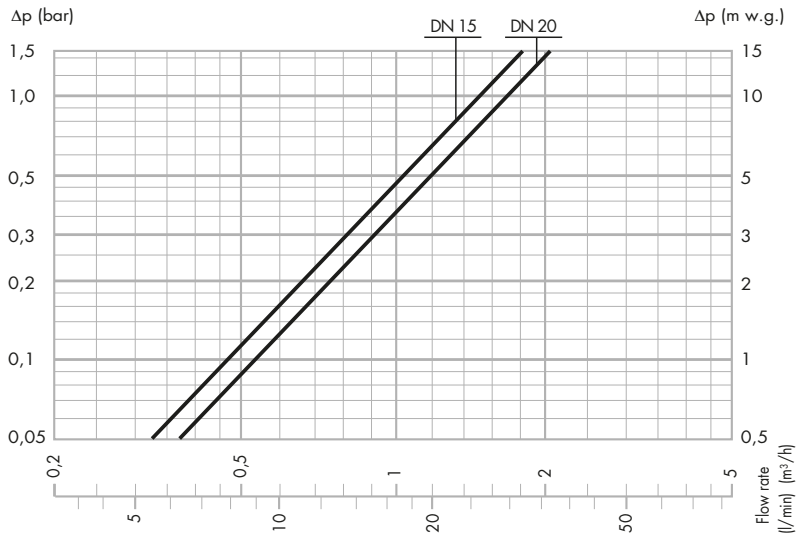

Code	DN	Size	Kv (m³/h)
252714	15	1/2"	1,5
252713	20	3/4"	1,7

Use

In view of their flow characteristics, the 2527 series thermostatic mixing valves can be installed to control the temperature for individual user fittings (for example wash basin, bidet, shower) or multiple user fittings. To ensure stable operation, the mixing valve must be guaranteed a minimum flow rate of 4 l/min. The system must always be sized in accordance with current legislation regarding the nominal flow rate to each user fitting.

Selecting the mixing valve size

If the design flow rate is known, taking into account simultaneous use of the sanitary appliances, the size of the mixing valve is chosen by checking on the graph provided the head loss produced. In this case, it is necessary to check the available pressure, the head loss in the system downstream of the mixing valve and the residual pressure to be guaranteed to the user appliances.



Sizing software available at www.caleffi.com
Apple Store and Google play.

Installation

Before installing the mixing valve, the pipework must be flushed to ensure that no circulating impurities can compromise its operation. It is recommended to install always strainers of adequate performance at the water inlet from the hydraulic network. The 2527 series mixing valve is equipped with strainers at the cold and hot water inlets. The 2527 series thermostatic mixing valve must be fitted according to the installation diagram provided in the instruction manual or in this brochure. The 2527 series thermostatic mixing valve can be installed in any position, vertically or horizontally.

The following marks are indicated on the valve body:

- hot water inlet by the letter "H" (Hot)
- cold water inlet by the letter "C" (Cold)
- mixed water outlet by the word "MIX"

Check valves

In systems with thermostatic mixing valves, check valves should be installed to prevent undesired backflow. The 2527 series thermostatic mixing valve incorporates check valves on the hot and cold water inlets, specific for solar hot water high temperatures

Commissioning

In view of the special applications for which the thermostatic mixing valve is used, it must be commissioned according to current regulations, by qualified technicians equipped with suitable temperature measurement instruments. We recommend using a digital thermometer for measuring the mixed water temperature.

Temperature adjustment

The temperature of the mixed water sent to the user is set at the desired value using the control knob with the graduated scale on the valve

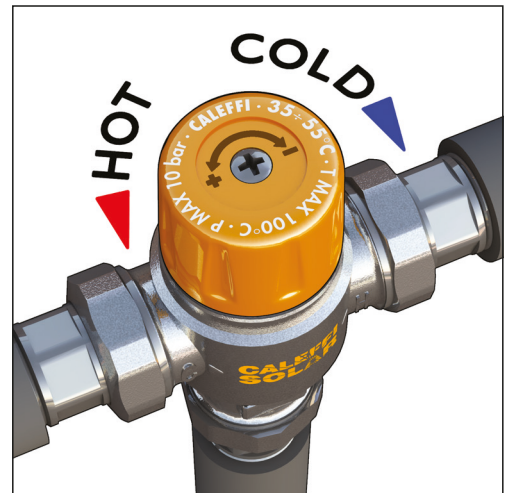

Thermal transient

During transient, following rapid changes in pressure, temperature or flow rate, the outlet mixed water temperature increases with respect to the initial set point and this increase must be of limited duration to guarantee safety. The anti-scald mixing valve always ensures that these conditions are respected.

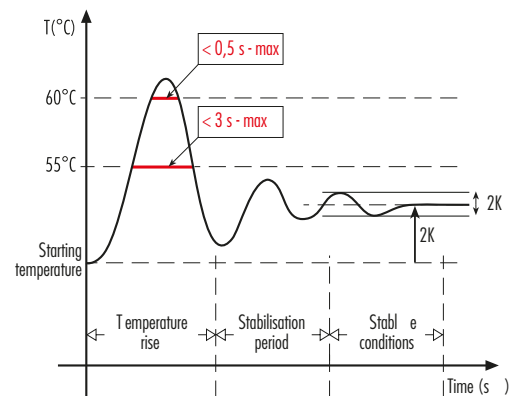

Application diagrams - System with thermal integration

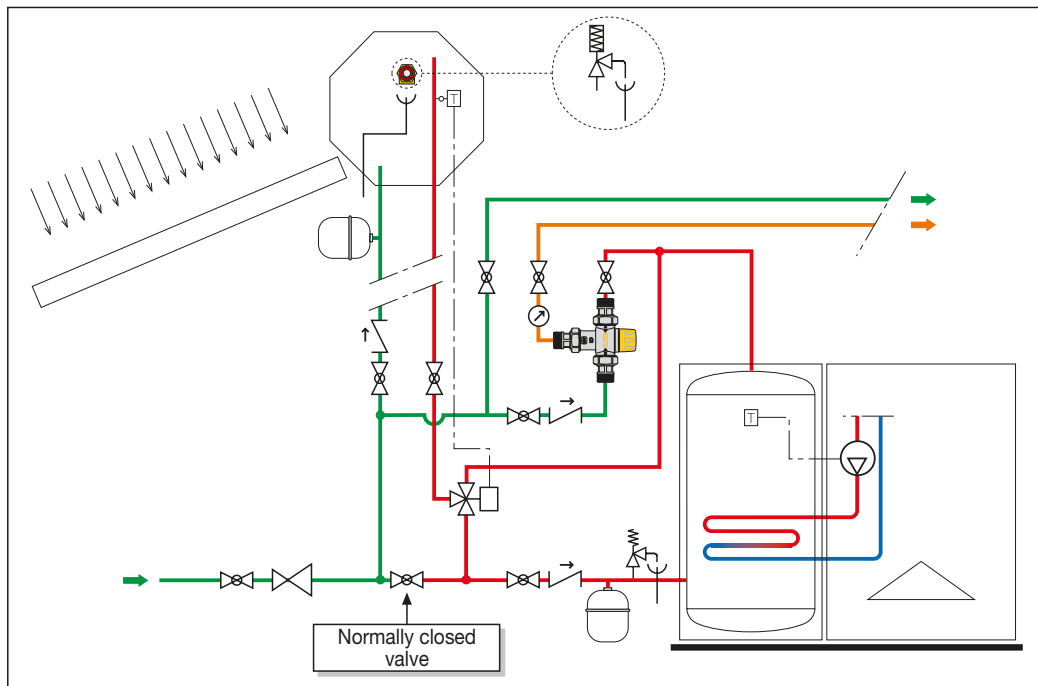

- Shut-off valve
- Pressure reducing valve
- Discharge tundish
- Check valve
- T/P safety relief valve
- Temperature gauge
- Expansion vessel
- Automatic diverter valve
- Thermostat
- Pump
- Safety relief valve

System with thermal integration and recirculation

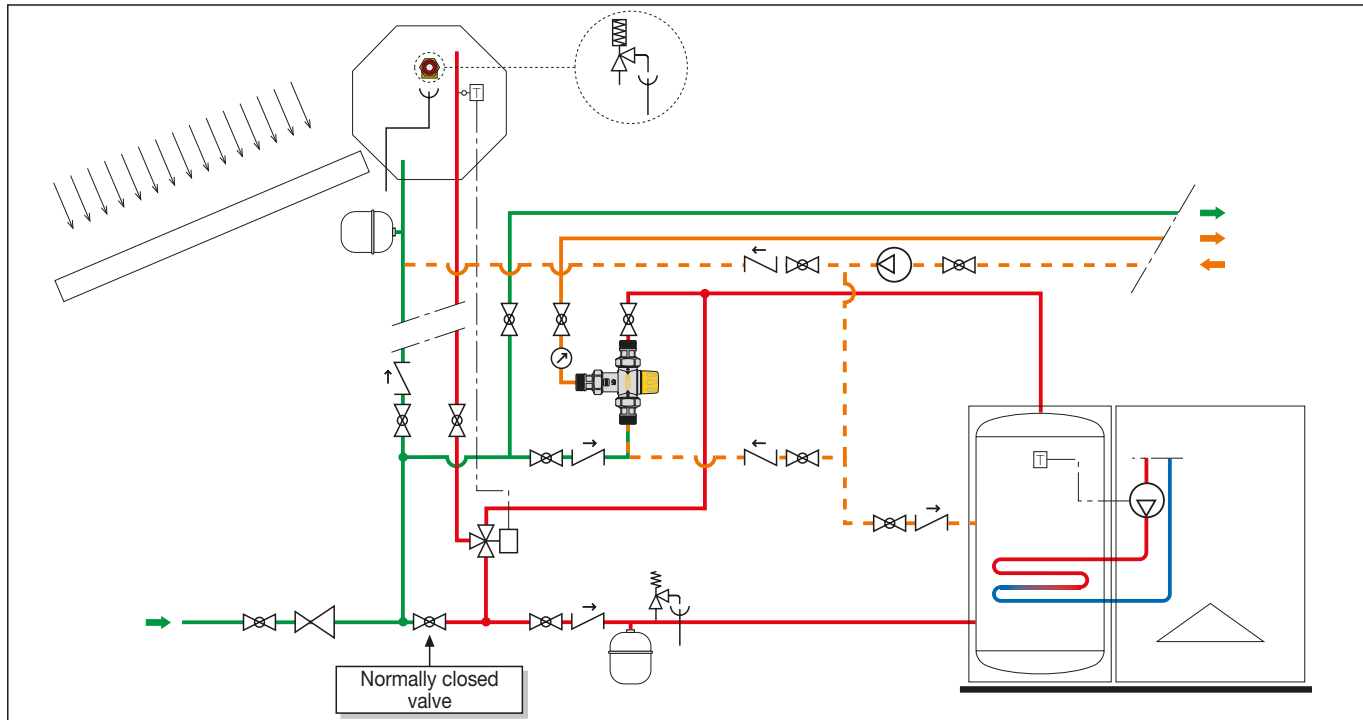

SPECIFICATION SUMMARIES

2527 series

Adjustable anti-scald thermostatic mixing valve for solar thermal systems. Size DN 15 (or DN 20). Connections 1/2" (or 3/4") M (ISO 228-1) with union. Brass body. Chrome plated. Obturator in PSU. Stainless steel springs. EPDM seal elements. ABScontrol knob. Maximum inlet temperature 100 °C. Adjustment range 35–55 °C. Accuracy ± 2 °C. Maximum working pressure(static) 10 bar. Maximum working pressure (dynamic) 5 bar. Maximum inlet pressures ratio (H/C or C/H) 2:1. Complete withstrainers and check valves at the inlets. Minimum temperature difference between the inlet hot water and the outlet mixedwater to ensure anti-scald performance 10 °C. Minimum flow rate for stable operation 4 l/min. Performance to standards NF 079 doc. 8, EN 15092, EN 1111, EN 1287.

We reserve the right to make changes and improvements to our products and the related technical data in this publication, at any time and without prior notice. The website www.caleffi.com always has the most up-to-date version of the document, which should be used for technical verifications.



Caleffi S.p.A.
 S.R. 229 n. 25 · 28010 Fontaneto d'Agogna (NO) · Italia
 Tel. +39 0322 8491 · Fax +39 0322 863305
 info@caleffi.com · www.caleffi.com
 © Copyright 2021 Caleffi