

Solar storage-to-boiler connection kit



264 - 265 series

**CALEFFI
SOLAR**



Function

The solar storage-to-boiler connection kits automatically control and optimize the thermal energy contained in a solar water storage, ensuring that domestic hot water is distributed throughout the system at a controlled optimum temperature.

The kits come complete with anti-scald thermostatic mixing valve, motorised diverter valve and thermostat with temperature probe for the solar water storage.

They ensure that users always receive hot water at the set temperature and switch the boiler on if the temperature of the water coming from the solar storage falls below the set point.

The kits are available in two versions, for use with either modulating or non-modulating boilers.

These compact kits are designed for quick and easy installation in both new and existing systems.

They come complete with a pre-formed shell protective cover.

Patent application No. MI2007A000936.

Product range

Code 264352 SOLARNOCAL Solar storage-to-boiler connection kit without thermal integration size 3/4"
Code 265352 SOLARINCAL Solar storage-to-boiler connection kit with thermal integration size 3/4"

Technical specifications

Materials

Mixing valve

Body:	dezincification resistant alloy CR EN 12165 CW602N, chrome plated
Obturator:	PSU
Springs:	stainless steel
Seals:	EPDM
Control knob:	ABS

Diverter valve

Body:	brass EN 12165 CW617N, chrome plated
Ball:	brass EN 12164 CW614N, chrome plated
Ball seal:	PTFE with EPDM O-Ring
Control stem seal:	two EPDM O-Rings
Union seals:	non-asbestos fibre

Actuator

Protective shell:	self-extinguishing polycarbonate
Colour:	grey RAL 9002

Protective cover:

Material:	PVC
Thickness:	7 mm
Density:	1,29 kg/dm ³
Working temperature range:	-5-110°C
Reaction to fire (EN 13501-1):	class B2
Connections:	- inlet and outlet: 3/4" M with union - boiler connection (265 series): 3/4" M

Performance

Diverter valve

Max. working pressure:	10 bar
Max. differential pressure:	10 bar
Working temperature range:	-5-110°C

Mixing valve

Max. working pressure:	10 bar (static); 5 bar (dynamic)
Adjustment temperature range:	35-55°C
Factory set:	43°C
Accuracy:	±2°C
Max. inlet temperature:	100°C
Max. inlet pressure ratio (H/C or C/H):	2:1
Minimum temperature difference between the inlet hot water and the outlet mixed water to ensure anti-scald performance:	10°C
Min. flow rate for stable operation:	4 l/min

Actuator

Three-contact type	
Electric supply:	230 V (ac)
Power consumption:	8 VA
Auxiliary microswitch contact rating:	0,8 A (230 V)
Protection class:	IP 44 (control stem in vertical position) IP 40 (control stem in horizontal position)
Operating time:	10 s
Ambient temperature range:	0-55°C
Dynamic torque:	6 N·m
Length of supply cable:	1 m

Thermostat

Electric supply:	230 V (ac)
Power consumption:	10 (2+8) VA
Adjustable temperature range:	35-50°C
Factory set:	45°C
Box protection class:	IP 65

Temperature probe

Working range:	-25-110°C
Time constant:	1 min
Response:	100 kΩ at 25°C
Two wire cable with Ø 4,5 mm probe	L = 2 m
Maximum distance:	10 m with 2 x 0,25 mm ² cable 100 m with 2 x 0,5 mm ² cable

Dimensions

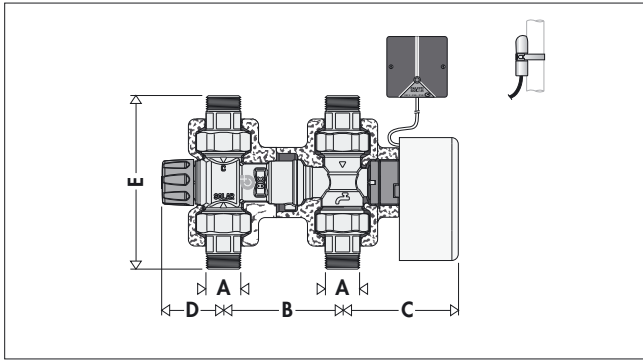

Code	A	B	C	D	E	Weight (kg)
264352	3/4"	90	87,5	45	131	2,3

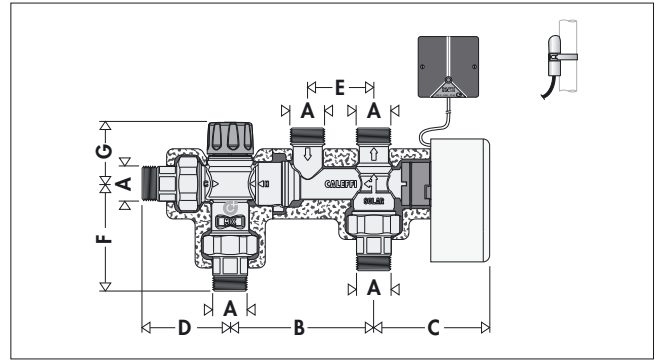

Code	A	B	C	D	E	F	G	Weight (kg)
265352	3/4"	108,5	87,5	66,5	50	81	45	2,3

High temperature and solar systems

In solar thermal systems with natural circulation in the primary circuit and a water storage with heating jacket, the temperature of the domestic water in the storage can vary considerably depending on the degree of solar radiation and can reach very high temperatures over long periods.

In summer, and if there is little water usage, the hot water at the storage outlet can actually reach temperatures around 98°C before the temperature and pressure safety relief valves are actuated.

At these temperatures, the hot water cannot be used directly, because of the danger of scalding for users.

Water temperatures over 50°C can cause burns very quickly. For example, at 55°C, partial burn occurs in about 30 seconds, whereas at 60°C partial burn occurs in about 5 seconds.

It is therefore necessary to use a thermostatic mixing valve able to:

- reduce the temperature of the water distributed throughout the domestic water system to a value lower than that in the storage and suitable for the end user. For reasons of safety, it is recommended to set the temperature of the mixed water distributed to the users to values no higher than 50°C;

- keep mixed water temperature constant despite variations in inlet temperature and pressure;
- continue functioning over time without any loss in performance and without problems due to the continuously high temperature of the incoming water;
- enable the high temperature water in the storage to last longer, by distributing it to the user circuit at a reduced temperature;
- have an anti-scald safety function in case of failure of the cold water supply.

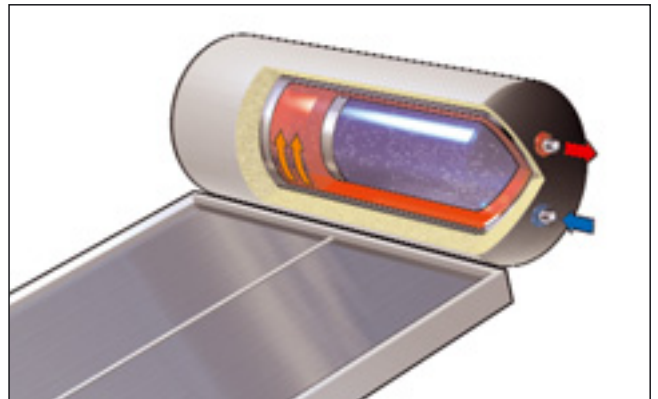

Exposure time to cause partial burns

Temperature	Adults	Children 0-5 years
70°C	1 s	--
65°C	2 s	0,5 s
60°C	5 s	1 s
55°C	30 s	10 s
50°C	5 min	2,5 min

Integration with boiler

Solar domestic water storages are normally installed in conjunction with boilers or water heaters. In this way, boilers or water heaters can be switched on to produce domestic hot water when solar radiation is insufficient, therefore the thermal energy available within the storage is low.

The following actions are necessary to control this type of system automatically and ensure the correct distribution of domestic hot water:

- install a motorised diverter valve between the solar water circuit and the boiler or water heater;
- install a thermostat with a temperature probe positioned in the solar water circuit, to operate the diverter valve depending on the water temperature;
- switch the boiler or water heater on if the temperature of the solar hot water is insufficient;
- connect the solar hot water circuit to the boiler or water heater according to the functioning mode of the boiler or water heater, which can be instant modulating, non modulating, or equipped with its own storage.

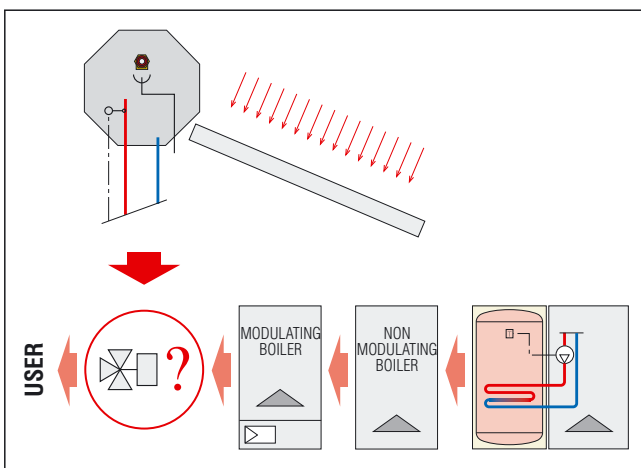

264 series SOLARNOCAL

Characteristic components

- 1) Diverter valve
- 2) Diverter valve actuator
- 3) Thermostatic mixing valve
- 4) Diverter valve control thermostat
- 5) Solar water storage temperature probe

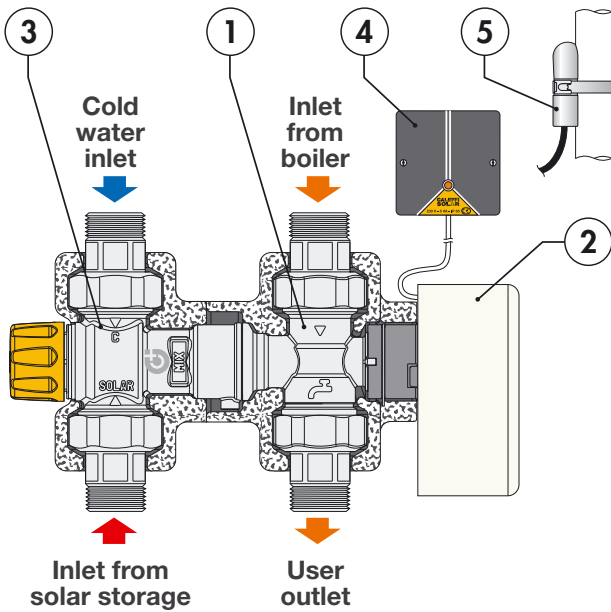

Operating principle

A thermostatic anti-scald mixing valve, at the kit inlet, controls the temperature of the water coming from the solar water storage. The thermostat, by means of the probe positioned on the hot water flow from the solar water storage, controls the diverter valve at the kit outlet.

Depending on the temperature set, the valve diverts the water towards the user circuit or activates the boiler circuit, **without thermal integration**.

Hydraulic diagram

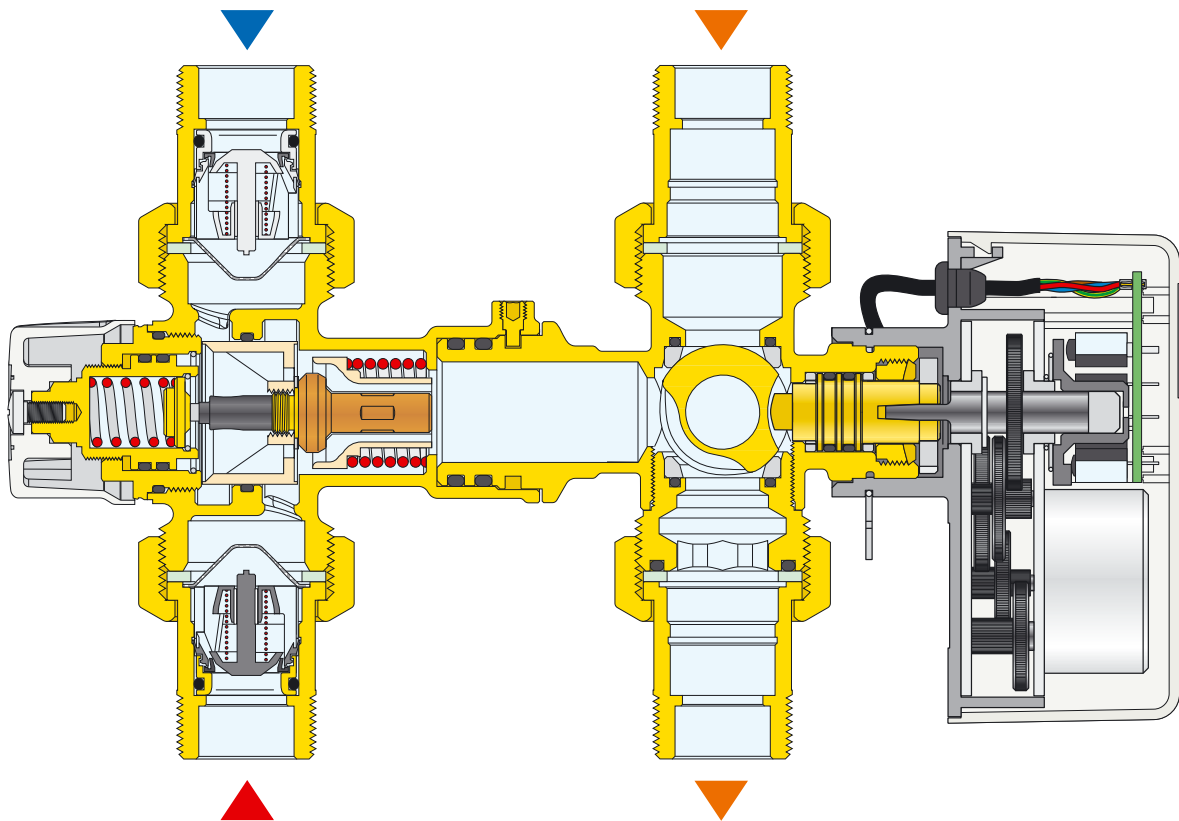
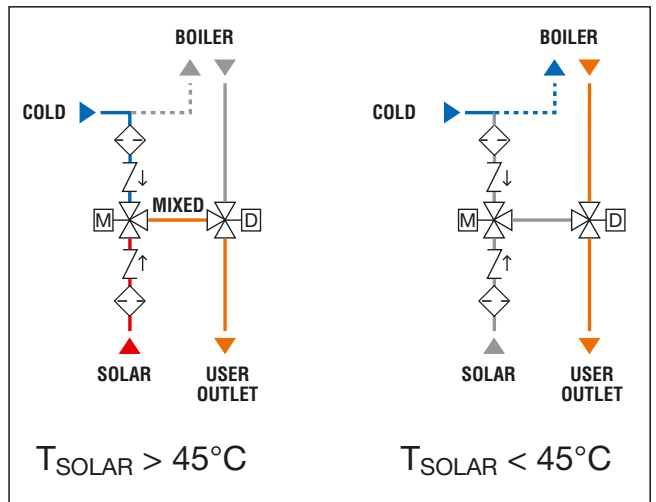

265 series SOLARINCAL

Characteristic components

- 1) Diverter valve
- 2) Diverter valve actuator
- 3) Thermostatic mixing valve
- 4) Diverter valve control thermostat
- 5) Solar storage temperature probe

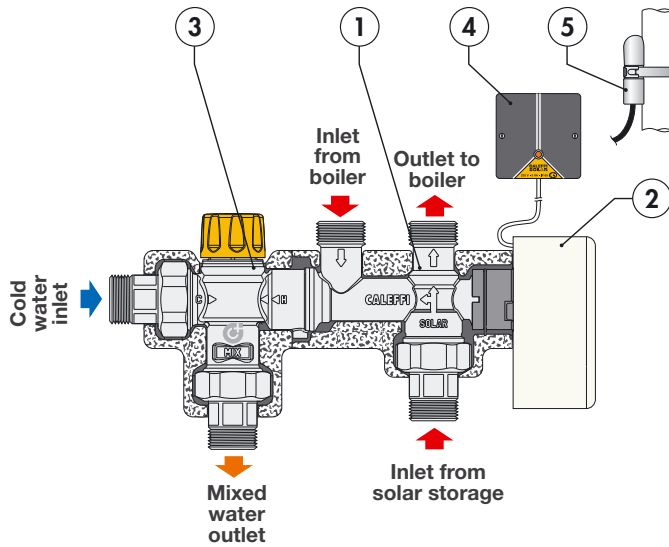

Operating principle

The thermostat, by means of the probe positioned on the hot water flow from the solar water storage, controls the diverter valve at the kit inlet.

Depending on the temperature set, the valve diverts the water towards the user circuit or activates the boiler circuit, **with thermal integration.**

A thermostatic anti-scald mixing valve, at the kit outlet, constantly controls the temperature of the water sent to the user.

Hydraulic diagram

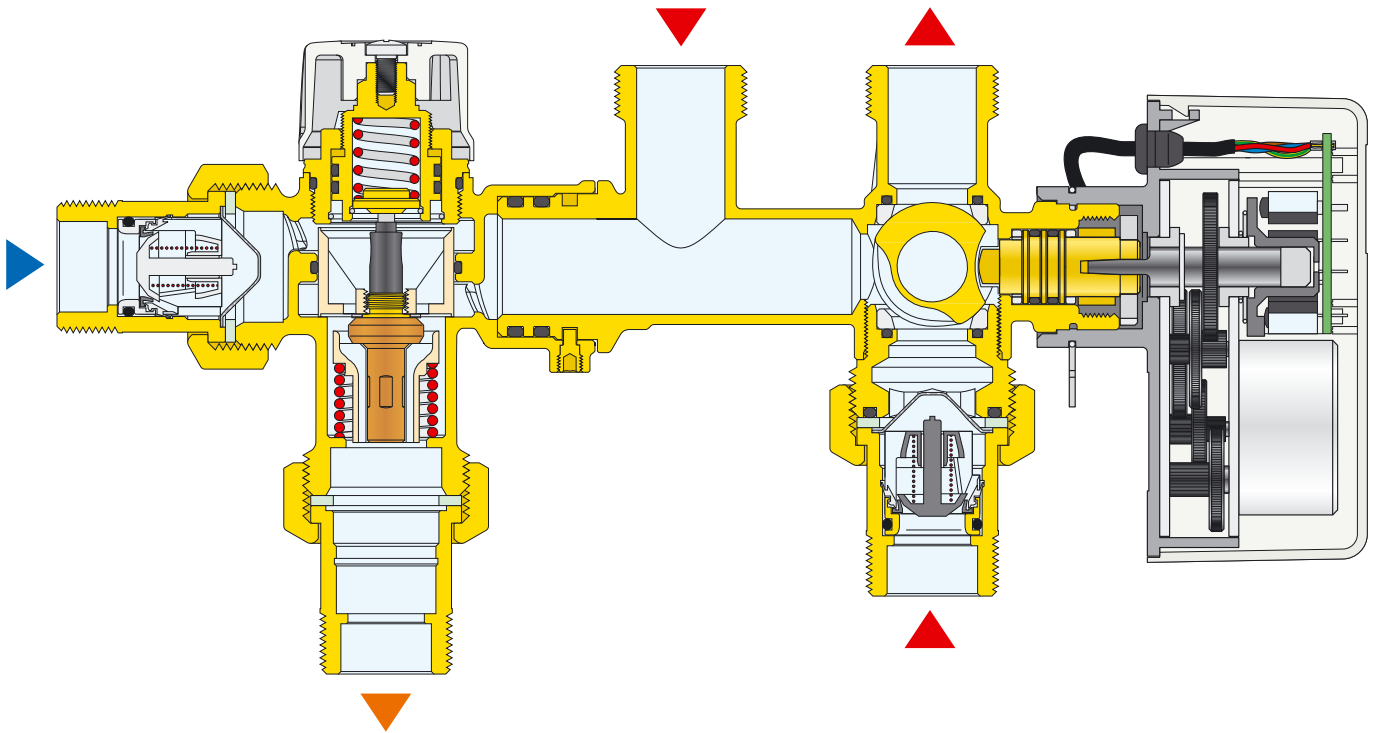
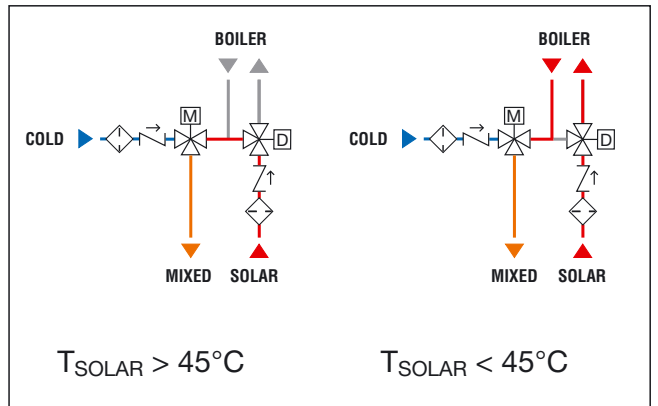

Construction details

Mixing valve

High resistance to temperature

Internal control components are designed to maintain constant the mixing valve performance with inlet hot water temperatures up to 100°C, in continuous operation.

Anti-scale materials

The materials used in constructing the mixing valve were selected to eliminate seizing due to limescale deposits. All functional parts have been made using a special anti-scale material with low friction coefficient, which ensures over time performance.

Anti-scald safety function

As a safety measure, in case of failure of the cold water supply, the valve immediately shuts off the flow of the hot water. This prevents dangerous burns. This performance is guaranteed if there is a minimum temperature difference between the inlet hot water and the outlet mixed water of 10°C. Also in case of failure of the hot water supply, the valve shuts off the cold water port and thus the outlet mixed water to prevent dangerous thermal shocks.

Diverter valve

Directions of flow and position indicator

Removing the actuator reveals a slot at the top of the control stem on which the shaft of the actuator acts:

- this slot allows the valve to be opened and closed manually with a screwdriver;
- the slot position allows to understand the flow direction depending on the ball position. This is extremely useful for system commissioning and checking.

Two diagrams follow here regarding the two valves types. As visible, the slot position shows the flow direction.

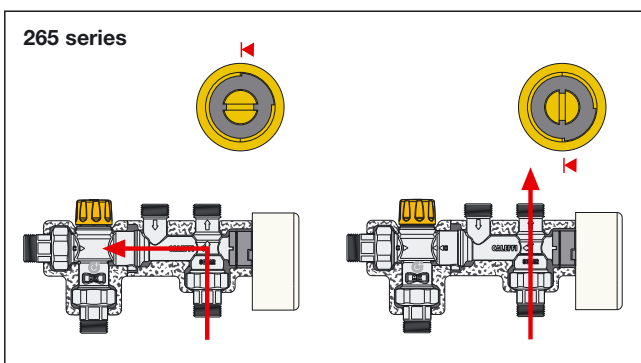
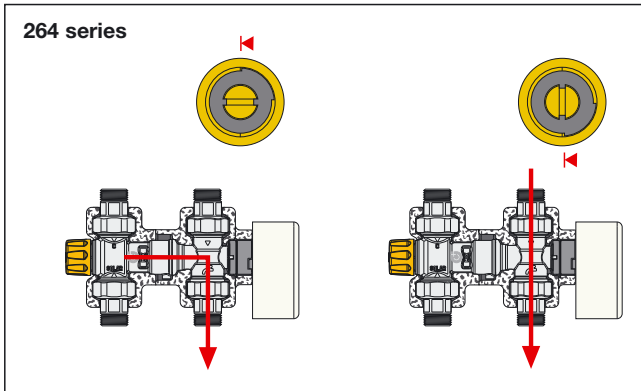

Valves are initially delivered with the slot vertical.

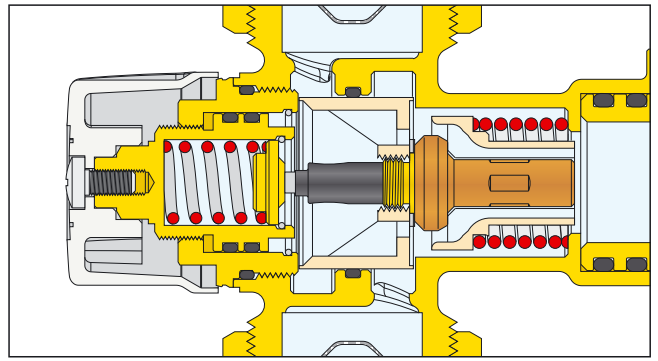

Actuator

Drive transmission

A taper coupling allows a constant connection between the valve control stem (A) and the output shaft of the gear actuator (B). This provides automatic compensation for the mechanical slack thanks to the thrust (C) of the fluid pressure on the control stem.

Valve-actuator coupling

An elastic steel fastener (D) allows the valve to be coupled to the actuator quickly and easily, by a simple clutch operation with automatic locking.

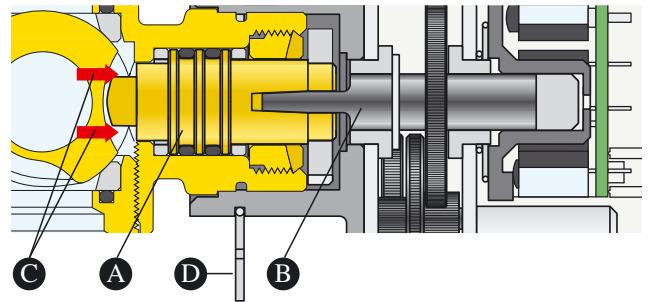

Cam and stop limit microswitches

A cam (A) operates the stop limit microswitches (B). This cam, which can move vertically, is supported by a tapered spring (C). This keeps the cam in constant contact with the microswitches and compensates for wear over time.

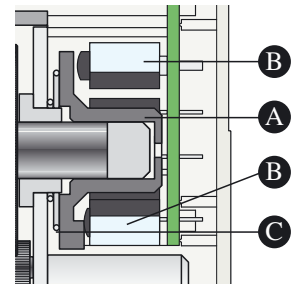

Auxiliary microswitch

The auxiliary microswitch closes at an average valve aperture of 80%.

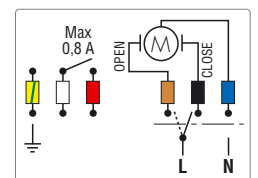

Diverter-mixing valve coupling

The diverter-mixing valve coupling on the Solarnocal and Solarinocal solar storage-to-boiler connection kits allows the mixing valve to rotate through 360° to satisfy all the possible installation needs. The kit comes complete with a special pre-formed protective cover.

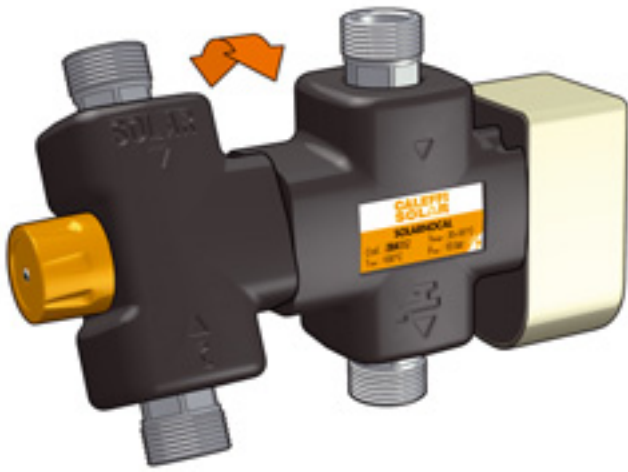

Hydraulic characteristics of the 264 series

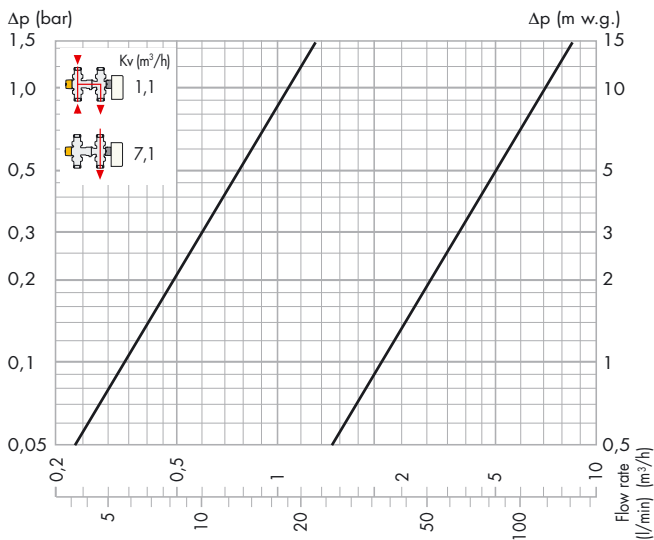

Hydraulic characteristics of the 265 series

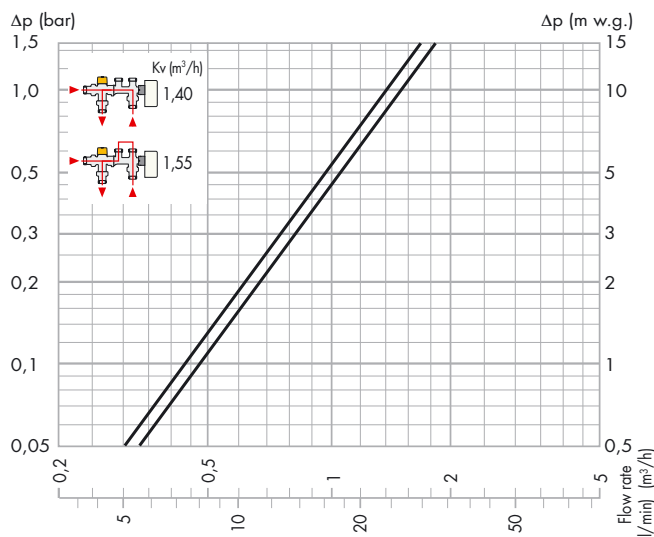

Application

Solar storage-to-boiler connection kits are generally installed near the boiler, at the outlet from the solar hot water storage, to ensure a constant temperature of the mixed water supplied to the user. Given their flow characteristics, thermostatic mixing valves can be installed to control water temperature both for single user points (e.g. washbasins, bidets, showers) and for multiple users. To ensure that the mixed water is supplied at the set temperature, a minimum flow rate of 4 l/min must be ensured to the mixing valves.

Checking the head loss in the kit

If the design flow rate is known and taking into account the simultaneous use of sanitary appliances, the head loss produced by the kit can be checked using the diagram.

It is necessary to check the available pressure, the head loss in the system downstream of the kit and the residual pressure to be guaranteed to user devices.

Installation

Before installing the kits, the pipework must be flushed to ensure that no circulating impurities can compromise their operation. It is recommended to install always strainers of adequate performance at the water inlet from the hydraulic network.

The kits must be fitted according to the installation diagram provided in the instruction manual or in this brochure.

The kits can be installed in any position, vertically or horizontally. They cannot, however, be installed with the actuator of the diverter valve upside down.

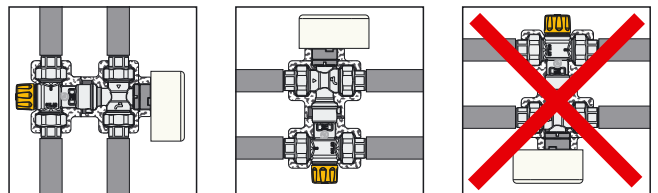

Check valves

In systems with thermostatic mixing valves, check valves should be installed to prevent undesired backflow. The kit with mixing valve incorporates check valves on the hot and cold water inlets.

Commissioning

In view of the special applications for which the thermostatic mixing valve is used, it must be commissioned according to current regulations, by qualified technicians equipped with suitable temperature measurement instruments. We recommend using a digital thermometer for measuring the mixed water temperature.

Temperature adjustment

The temperature is set to the desired value by means of the control knob on the thermostatic mixing valve.

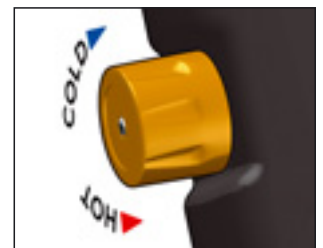

Valve position indicator

The thermostat is equipped with a LED indicating the diverter valve position, showing whether it is connected to the solar circuit or the boiler.

The LED is a two colour type:

Green: solar circuit active

Red: boiler circuit active

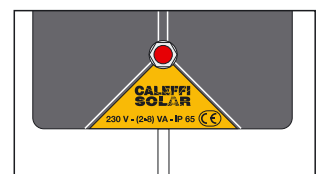
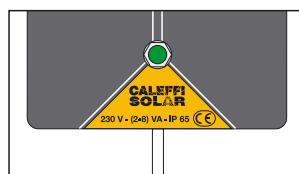

Set temperature adjustment / Electrical connections

The thermostat is adjusted in the factory to operate at a temperature of 45°C, thus diverting the water to the boiler if the temperature falls below this set value. If necessary, the thermostat trip value can be adjusted between 35 and 50°C, by turning the trimmer to suit the needs of the system and boiler.

In 264 series kit it's possible to set the temperature to a value between 50 and 70°C, above which the valve is again deviated to the solar water circuit. In this way, the diverter valve only operates when the solar water storage is full of enough thermal energy, avoiding excessive variations in the temperature of the distributed hot water caused by the action of the diverter valve.

264 series Solarnocal

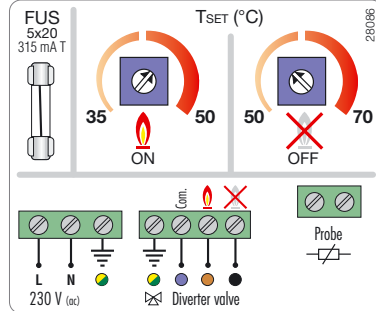

Factory set:
 ON: 45°C
 OFF: 60°C

265 series Solarincal

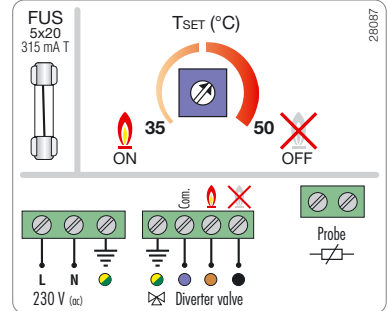

Factory set:
 ON: 45°C
 OFF: 45°C

Application diagrams

264 series Solarnocal

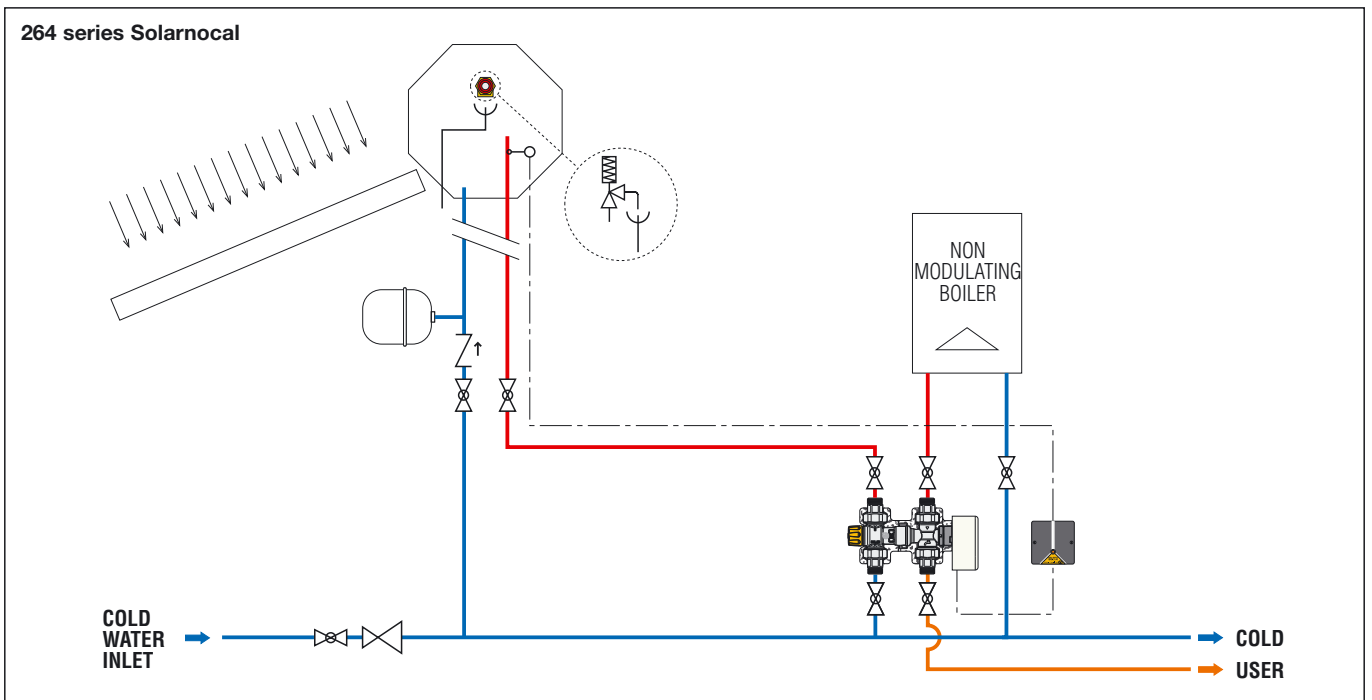

265 series Solarincal

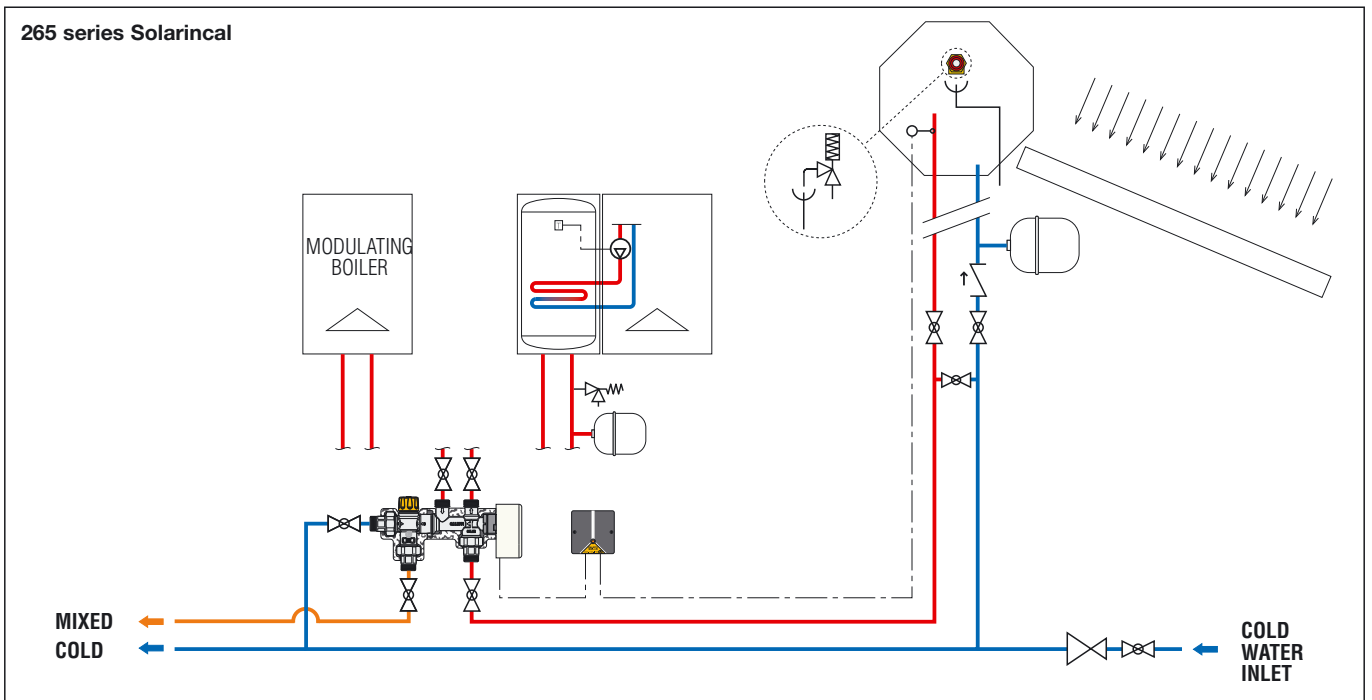

SPECIFICATION SUMMARIES

264 series

Solar storage-to-boiler connection kit without thermal integration. Inlet and outlet threaded connections 3/4" M with unions. Medium drinking water.

Consisting of:

- Mixing valve: dezincification resistant alloy body, chrome plated; PSU obturator; stainless steel springs; EPDM seals; ABS control knob. Maximum working pressure 10 bar (static), 5 bar (dynamic); adjustment temperature range 35–55°C; factory set 43°C; accuracy $\pm 2^\circ\text{C}$; maximum inlet temperature 100°C; maximum inlet pressures ratio (H/C or C/H) 2:1; minimum temperature difference between the inlet hot water and the outlet mixed water to ensure anti-scald performance 10°C; minimum flow rate for a stable operation 4 l/min.
- Diverter valve: brass body, chrome plated; brass ball, chrome plated; PTFE ball seal with EPDM O-Ring; double EPDM O-Ring control stem seal; non-asbestos fibre union seal. Maximum working pressure 10 bar; maximum differential pressure 10 bar; working temperature range -5–110°C.
- Actuator with protective shell in self-extinguishing polycarbonate; colour grey RAL 9002.
- Three-contact actuator with auxiliary microswitch; electric supply 230 V (ac); power consumption 8 VA; auxiliary microswitch contact rating 0,8 A (230 V); protection class IP 44 with control stem in vertical position, IP 40 with control stem in horizontal position; operating time 10 s; ambient temperature range 0–55°C; dynamic torque 6 N·m; length of electric supply cable 1 m.
- PVC pre-formed shell protective cover. Temperature range -5–110°C.
- Thermostat: electric supply 230 V (ac); power consumption 10 (2+8) VA; adjustable temperature range 35–50°C; factory set 45°C; box protection class IP 65.
- Temperature probe: working range 0–100°C; time constant 1 min; response 100 k Ω at 25°C; two wire cable with \varnothing 4,5 mm probe, L = 2 m.

265 series

Solar storage-to-boiler connection kit with thermal integration. Inlet and outlet threaded connections 3/4" M with unions, boiler connection 3/4" M. Medium drinking water.

Consisting of:

- Mixing valve: dezincification resistant alloy body, chrome plated; PSU obturator; stainless steel springs; EPDM seals; ABS control knob. Maximum working pressure 10 bar (static), 5 bar (dynamic); adjustment temperature range 35–55°C; factory set 43°C; accuracy $\pm 2^\circ\text{C}$; maximum inlet temperature 100°C; maximum inlet pressures ratio (H/C or C/H) 2:1; minimum temperature difference between the inlet hot water and the outlet mixed water to ensure anti-scald performance 10°C; minimum flow rate for a stable operation 4 l/min.
- Diverter valve: brass body, chrome plated; brass ball, chrome plated; PTFE ball seal with EPDM O-Ring; double EPDM O-Ring control stem seal; non-asbestos fibre union seals. Maximum working pressure 10 bar; maximum differential pressure 10 bar; working temperature range -5–110°C.
- Actuator with protective shell in self-extinguishing polycarbonate; colour grey RAL 9002.
- Three-contact actuator with auxiliary microswitch; electric supply 230 V (ac); power consumption 8 VA; auxiliary microswitch contact rating 0,8 A (230 V); protection class IP 44 with control stem in vertical position, IP 40 with control stem in horizontal position; operating time 10 s; ambient temperature range 0–55°C; dynamic torque 6 N·m; length of electric supply cable 1 m.
- PVC pre-formed shell protective cover. Temperature range -5–110°C.
- Thermostat: electric supply 230 V (ac); power consumption 10 (2+8) VA; adjustable temperature range 35–50°C; factory set 45°C; box protection class IP 65.
- Temperature probe: working range 0–100°C; time constant 1 min; response 100 k Ω at 25°C; two wire cable with \varnothing 4,5 mm probe, L = 2 m.

We reserve the right to make changes and improvements to the products and related data in this publication, at any time and without prior notice.



CALEFFI S.P.A. · I · 28010 FONTANETO D'AGOGNA (NO) · S.R. 229, N.25 · TEL. +39 0322 8491 R.A. · FAX +39 0322 863723

· www.caleffi.com · info@caleffi.com ·

© Copyright 2008 Caleffi