

Dimensions

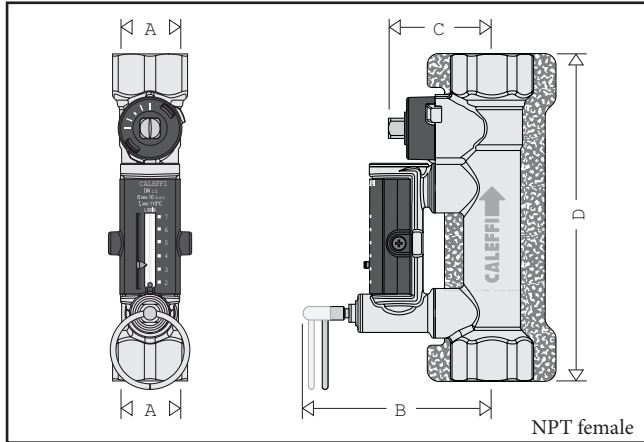

Code	A	B	C	D	Wt (lb/kg)
132432A	1/2"	3 5/16"	1 13/16"	5 3/4"	2.0/0.9
132552A	3/4"	3 5/16"	1 13/16"	5 3/4"	1.8/0.8
132662A	1"	3 3/8"	1 7/8"	6 1/4"	2.4/1.1
132772A	1 1/4"	3 1/2"	2"	6 1/2"	2.8/1.3
132882A	1 1/2"	3 5/8"	2 1/4"	6 3/4"	3.4/1.5
132992A	2"	3 3/4"	2 1/2"	7"	4.4/2.0

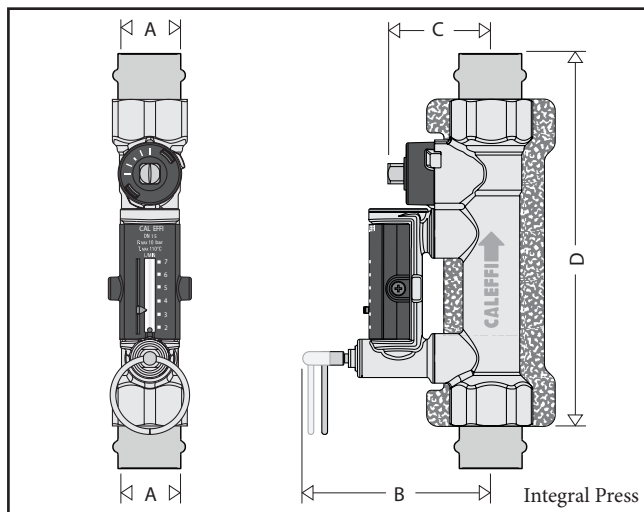

Code	A	B	C	D	Lay Length	Wt (lb/kg)
132436A	1/2"	3 5/16"	1 13/16"	8"	6 1/4"	2.2/1.0
132556A	3/4"	3 5/16"	1 13/16"	8"	6"	2.0/0.9
132666A	1"	3 3/8"	1 7/8"	8 1/4"	6 1/4"	2.4/1.1
132776A	1 1/4"	3 1/2"	2"	9"	7"	2.8/1.3
132886A	1 1/2"	3 5/8"	2 1/4"	10"	7"	3.4/1.5
132996A	2"	3 3/4"	2 1/2"	10 5/8"	7 3/8"	4.4/2.0

Flow rate ranges

Code	Connection	Flow rate (GPM)	Full open Cv
132432A	1/2" NPT	1/2 - 1 1/4	1.0
132552A	3/4" NPT	2.0 - 7.0	6.3
132662A	1" NPT	3.0 - 10.0	8.3
132772A	1 1/4" NPT	5.0 - 19.0	15.2
132882A	1 1/2" NPT	8.0 - 32.0	32.3
132992A	2" NPT	12.0 - 50.0	53.7

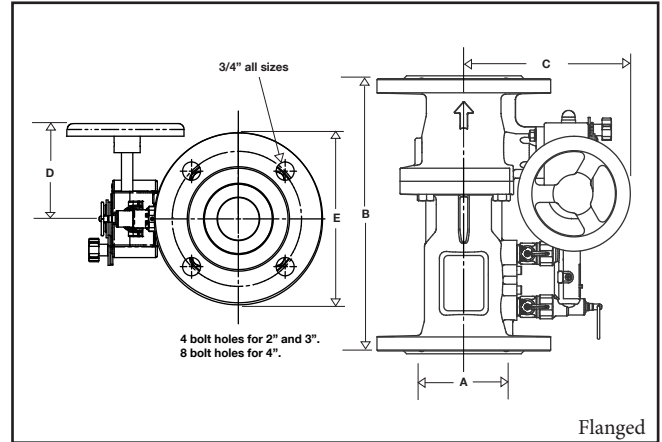

Code	A	B	C	D	E	Bolt circle dia	Wt (lb/kg)
132060A	2 1/2"	11 7/16"	6 31/32"	3 7/8"	7"	5 1/2"	32/15
132080A	3"	12 7/32"	7 9/32"	3 7/8"	7 1/2"	6"	40/18
132100A	4"	13 25/32"	7 29/32"	3 7/8"	9"	7 1/2"	57/26

Flow rate ranges

Code	Connection	Flow rate (GPM)	Full open Cv
132060A	2 1/2" flange	30 - 105	87
132080A	3" flange	38 - 148	164
132100A	4" flange	55 - 210	242

Advantages of balanced circuits

Balanced circuits have the following principal benefits:

1. The system emitters operate properly in heating, cooling and dehumidification, saving energy and providing greater comfort.
2. The zone circuit pumps operate at maximum efficiency, reducing the risk of overheating and excessive wear.
3. High fluid velocities which can result in noise and abrasion are avoided.
4. The differential pressures acting on the circuit control valves are reduced preventing faulty operation.

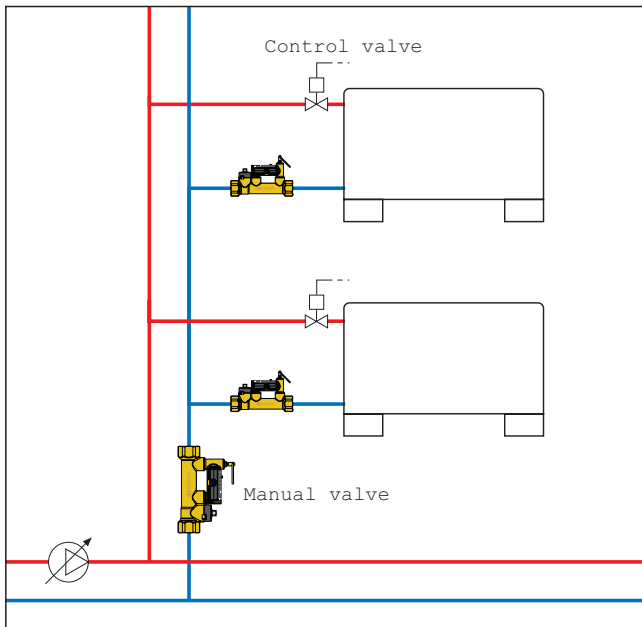

Operating principle

The balancing valve is a hydraulic device that controls the flow rate of the heating/cooling transfer fluid.

The control mechanism is a ball valve (1), operated by a control stem (2). The flow rate is manually and properly set by use of the convenient onboard flow meter (3) housed in a bypass circuit on the valve body. This circuit is automatically shut off during normal operation. The flow rate is indicated by a metal ball (4) sliding inside a transparent channel (5) with an integral graduated scale (6).

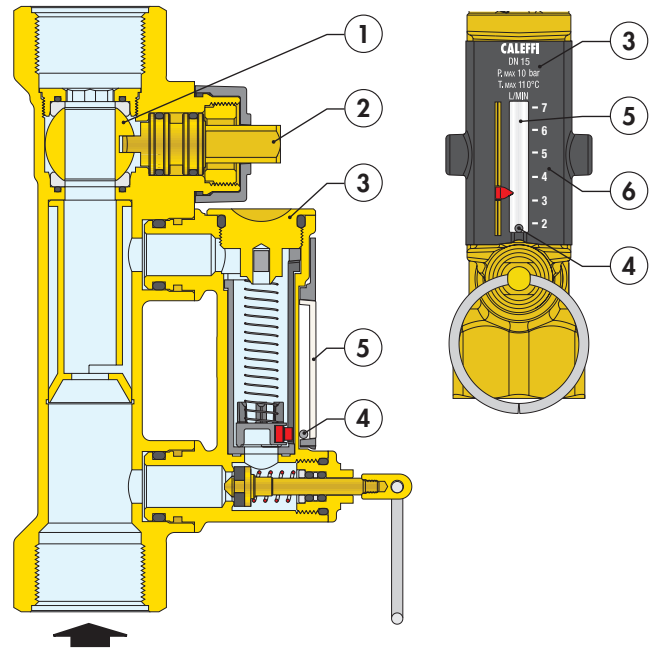

Construction details

Flow meter

When activated, the flow rate is indicated on the flow meter housed in a bypass circuit on the valve body. When finished reading the flow rate, the flow meter is automatically shut off, isolating it during normal operation.

Use of a flow meter greatly simplifies the process of system balancing since the flow rate can be measured and controlled at any time without differential pressure gauges or reference charts. The onboard flow meter eliminates the need to calculate valve settings during system setup. Additionally, the unique onboard flow meter offers unprecedented time and cost savings by eliminating the long and difficult procedure of calculating pre-settings associated with using traditional balancing devices.

The by-pass circuit easily detaches for cleaning.

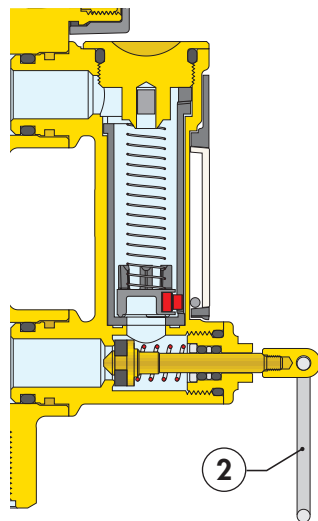

Flow meter bypass valve

The bypass valve (1) opens and closes the circuit between the flow meter and the valve. The bypass valve is easily opened by pulling the operating ring (2), and is automatically closed by the internal return spring (3) when finished reading the flow rate. The spring and the EPDM seal (4) provide a reliable seal to isolate the flow meter during normal operation, protecting potential debris from interfering with spring/magnetic disc mechanism.

The operating ring (2) material has low thermal conductivity to avoid burns if the flow meter is opened while hot fluid is passing through the valve.

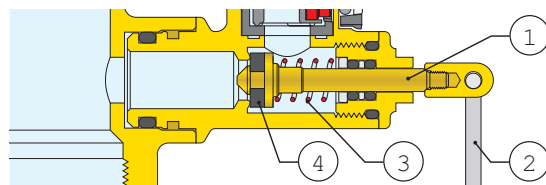

Ball/magnet indicator

The metal ball (4) that indicates the flow rate is not in direct contact with the heating/cooling transfer fluid passing through the flow meter.

This is an effective and innovative measuring system in which the ball slides up and down inside a transparent channel (5) that is isolated from the fluid flowing through the body of the flow meter. The ball is moved by a magnet (6) connected to a float (7). In this way the flow rate indication system **remains perfectly clean and provides reliable readings over time.**

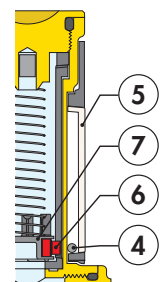

Complete closing and opening of the valve

The valve can be completely closed and opened. A slot on the control stem indicates the valve position. When the control stem is turned fully clockwise (the slot is perpendicular to the axis of the valve), the valve is fully closed (A). When the control stem is turned fully counter-clockwise (the slot is parallel to the axis of the valve), the valve is fully open (B).

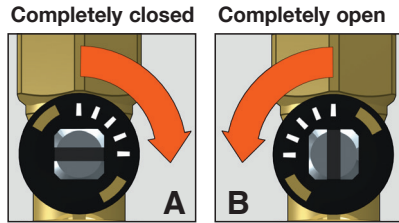

For the flanged version, rotate the adjusting handwheel 90° for the complete opening and closing of the valve as shown in (A) and (B). When at the desired position, lock the adjustment screw.

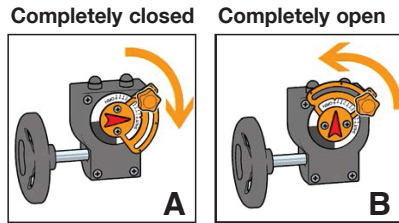

Insulation

The 132 series threaded version is supplied with a hot pre-formed insulating shell. This system ensures perfect heat insulation and keeps out water vapor from the environment. Additionally, this type of insulation is ideal in cold water circuits as it prevents condensation from forming on the surface of the valve body.

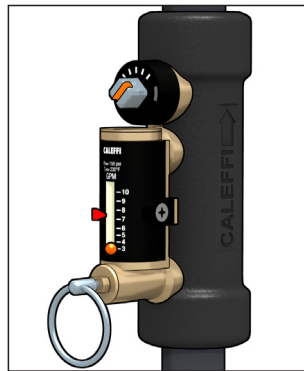

Installation

Install the balancing valve in a location that ensures free access to the flow meter shutoff valve, control stem and flow rate indicator. To ensure accurate flow measurement, straight sections of pipe installed as shown is recommended.

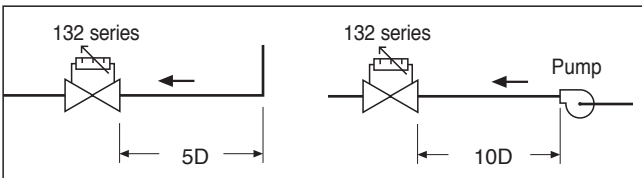

The valve can be installed in any position with respect to the flow direction shown on the valve body. Additionally, the valve can be installed either horizontally or vertically.

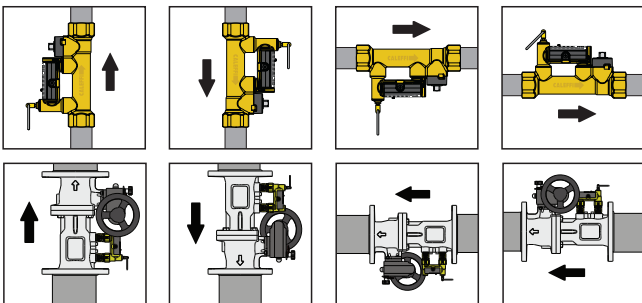

Do not install in direct sunlight.

Hydraulic characteristics at 100% open

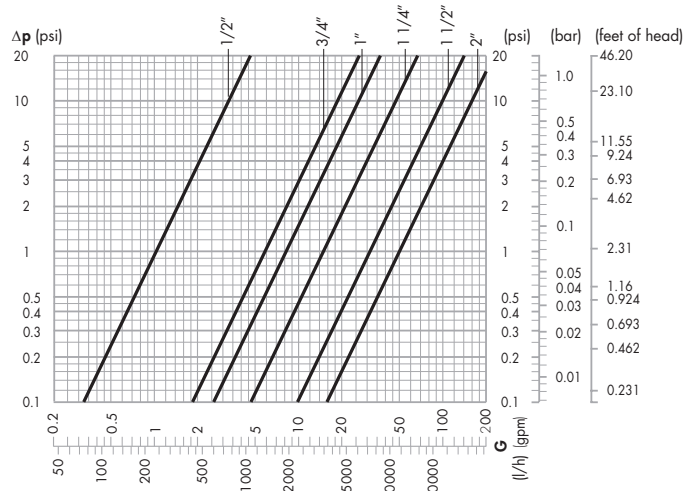

Code	Connection	Flow rate (GPM)	Full open Cv
132432A	1/2" NPT	1/2 - 1 1/4	1.0
132552A	3/4" NPT	2.0 - 7.0	6.3
132662A	1" NPT	3.0 - 10.0	8.3
132772A	1 1/4" NPT	5.0 - 19.0	15.2
132882A	1 1/2" NPT	8.0 - 32.0	32.3
132992A	2" NPT	12.0 - 50.0	53.7

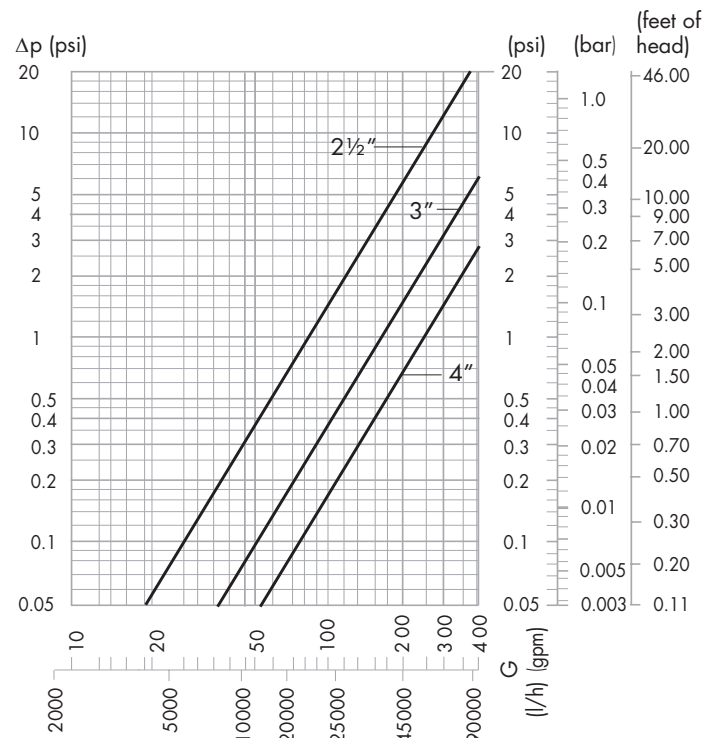

Code	Connection	Flow rate (GPM)	Full open Cv
132060A	2 1/2" flange	30 - 105	87
132080A	3" flange	38 - 148	164
132100A	4" flange	55 - 210	242

Flow rate adjustment, threaded version

The flow rate is adjusted as follows:

A. With the aid of the flow rate indicator (1), mark the desired flow rate.

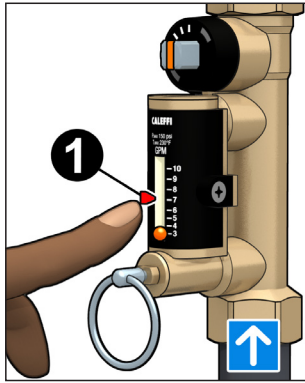

B. Use the operating ring (2) to open the bypass valve slowly. This allows fluid to flow through the flow meter (3). The bypass valve is automatically closed under normal operating conditions.

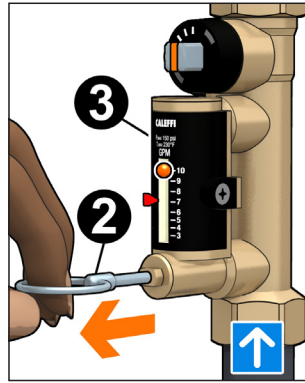

C. While holding the bypass valve open, use a wrench to turn the valve control stem (4) to adjust the flow rate slowly. The resulting flow rate is indicated by the metal ball (5) that slides up and down inside a transparent channel (6) marked by a graduated scale in GPM.

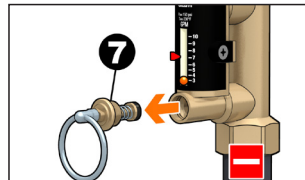
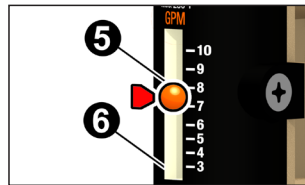
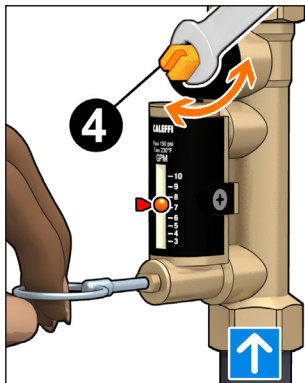

D. Once the flow rate is properly adjusted, release the operating ring (2) of the bypass valve. The valve will automatically return to the closed position by means of an internal spring.

E. A replacement bypass valve stem (7) with operating ring is available in event it is damaged and inoperable. Order code F19346.

G. A replacement flowmeter is available if this is damaged and inoperable.

Code	Flow rate (GPM)
F000940	1/2 - 1 3/4
F000941	2.0 - 7.0
F000942	3.0 - 10.0
F000943	5.0 - 19.0
F000944	8.0 - 32.0
F000945	12.0 - 50.0
F000946	30 - 105
F000947	38 - 148
F000948	55 - 210

Flow rate adjustment, flanged version

The flow rate is adjusted as follows:

A. With the aid of the flow rate indicator (1), mark the desired flow rate.

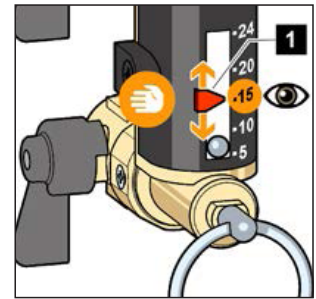

B. Open the ball shut-off valves (2). Use the operating ring (3) to open the bypass valve slowly. This allows fluid to flow through the flow meter (4). The bypass valve is automatically closed under normal operating

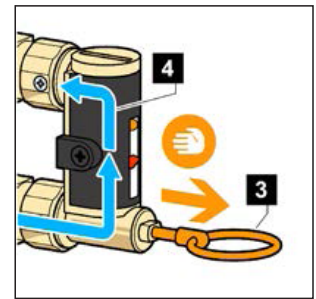
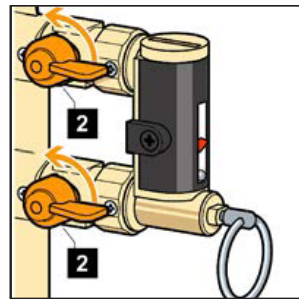

C. Keeping the flow meter bypass valve open, turn the flow rate adjusting handwheel (5). Flow rate is indicated by the metal ball (6) moving inside a transparent cylinder (7) alongside a graduated scale in GPM.

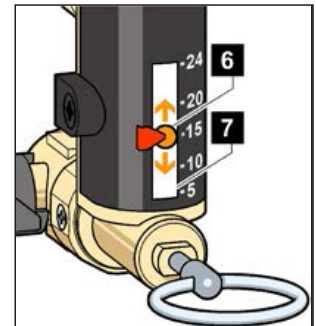
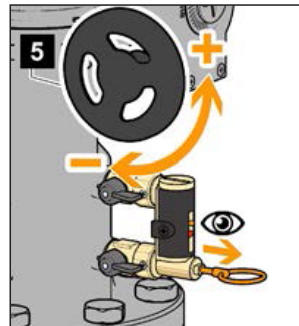

D. Once the flow rate is properly adjusted, release the operating ring (8) of the bypass valve. The valve will automatically return to the closed position by means of an internal spring. Close the ball shut-off valves (2).

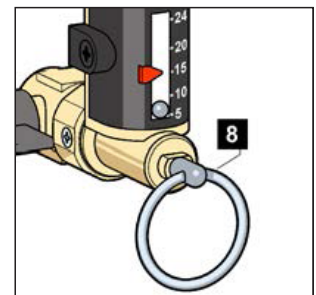

E. After completing the flow rate adjustment to the desired setting, the flow rate indicator (1) can be used as a memory pointer for reference.

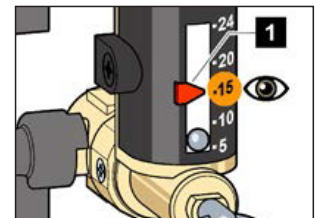
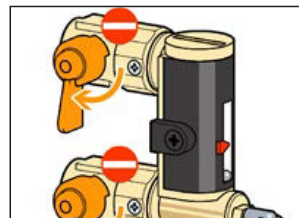

Accessories

Isolation ball valves

The NA108 series low-lead brass full-port ball valves are designed for isolating QuickSetter balancing valves with the 1/2" through 2" NPT female connections. The isolation valve easily installs in the inlet and outlet sides of the valve body using a close nipple. The NA108 series have an extended stem which allows operation if the valve body gets insulated. There is no need to purchase an expensive separate stem extension which then has to be field-installed between the valve body and handle. The valve features a blowout proof stem, PTFE seats, double o-ring stem seals, lead free brass ball and stem, and polyamide thermal plastic T- handle.



Code	Description
NA10824	1/2" FNPT
NA10825	3/4" FNPT
NA10826	1" FNPT
NA10827	1 1/4" FNPT
NA10828	1 1/2" FNPT
NA10829	2" FNPT

Technical specifications of ball valve

Materials

Body and end connection:

high tensile strength forged low-lead brass C28500

Ball and stem: low-lead brass C28500

Stem nut: steel (CL04)

Seats (2): PTFE

90° stop: hot rolled steel (DD11)

O-ring stem seals (2): nitrile butadiene rubber (NBR) & fluoro-elastomer (FKM)

Thrust washer and packing ring: PTFE

Black T-handle: polyamide thermal plastic (PA6.6)

Handle top cap: acrylonitrile butadiene styrene (ABS)

Performance

Suitable Fluids: water, glycol solutions

Max. percentage of glycol: 50%

Pressure rating: 600 WOG-150WSP

Working temperature range: -4 – 366°F (-20 – 186°C)

Shutoff performance: bubble tight

Connections:

Main connections: 1/2", 3/4", 1", 1-1/4", 1-1/2" & 2" NPT female inlet and outlet

Close nipples

The NA108 series full-port ball valves, designed for isolating QuickSetter balancing valves, easily installs in the inlet and outlet sides of the valve body using a close nipple. The following codes can be ordered separately for field installation with separately sourced NA108 series ball valves.

Code	Description
NA10834	1/2" NPT nipple
NA10835	3/4" NPT nipple
NA10836	1" NPT nipple
NA10837	1 1/4" NPT nipple
NA10838	1 1/2" NPT nipple
NA10839	2" NPT nipple

Replacement flowmeter



Code	Description
F0000940	Replacement flowmeter 0.5 to 1.75 GPM
F0000941	Replacement flowmeter 2.0 to 7.0 GPM
F0000942	Replacement flowmeter 3.0 to 10 GPM
F0000943	Replacement flowmeter 5.0 to 19 GPM
F0000944	Replacement flowmeter 8 to 32 GPM
F0000945	Replacement flowmeter 12 to 50 GPM
F0000946	Replacement flowmeter 30 to 105 GPM
F0000947	Replacement flowmeter 38 to 148 GPM
F0000948	Replacement flowmeter 55 to 210 GPM
F19346	Replacement by-pass valve stem*

*with operating ring

Application diagrams

The balancing valve with the flow meter should be installed on the circuit return pipe.

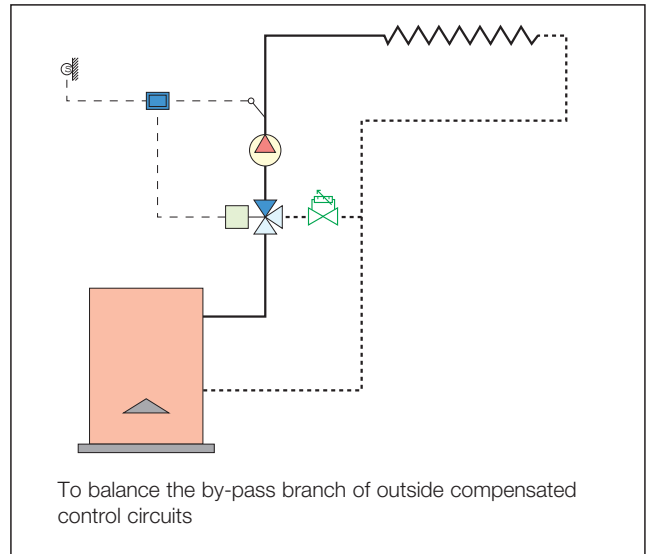
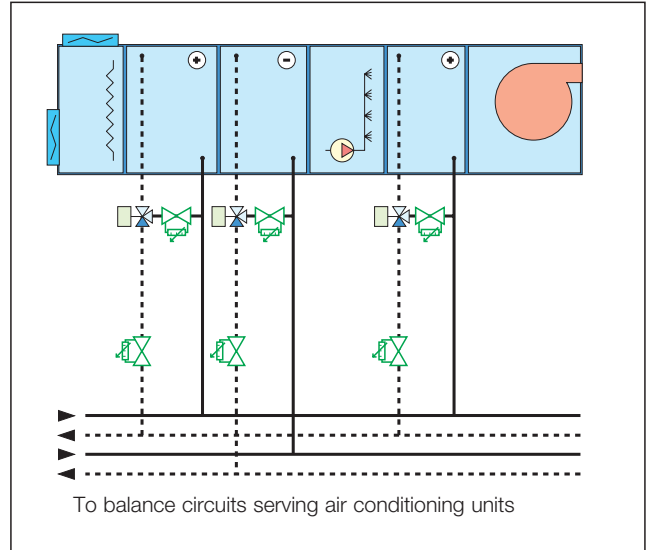
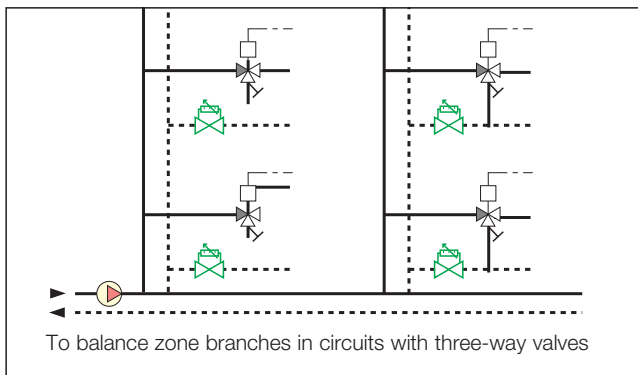
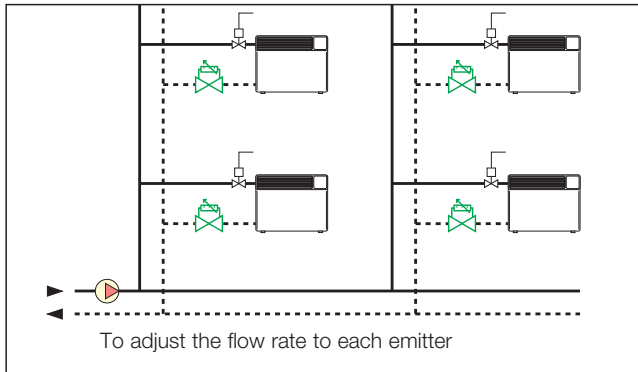
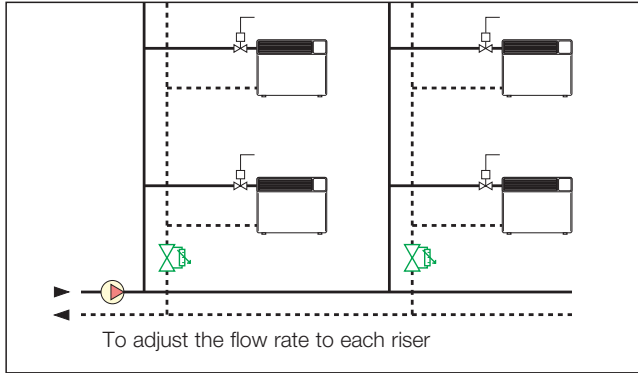

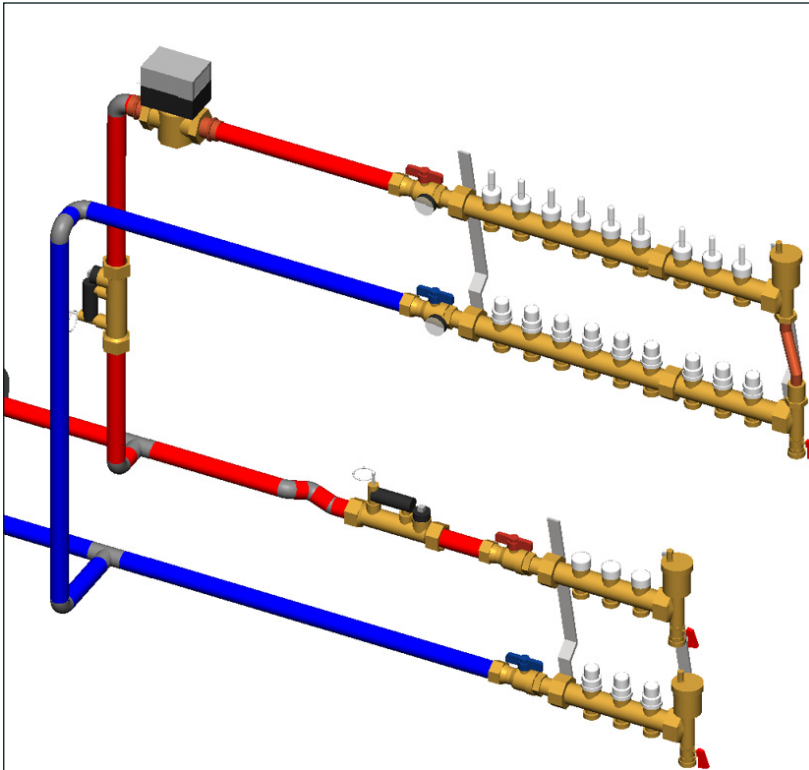

Find us in
MasterSpec®
 a product of The American Institute of Architects

<https://get.caleffi.info/specpoint>



find BIM Revit files and system templates at
<https://bim.caleffi.com/en-us>

SPECIFICATION SUMMARIES

132 series with threaded and press connections

Balancing valve with flow meter. NPT Female by Female threaded and integral press connections 1/2", 3/4", 1", 1 1/4", 1 1/2", 2". Brass body. Brass ball. Brass ball control stem, chrome plated. PTFE ball seal seat. PSU control stem guide. Brass flow meter body. Brass flow meter bypass valve stem, chrome plated. Stainless steel flow meter springs. PSU flow meter float and indicator cover. Peroxide-cured EPDM seals. With pre-formed shell insulation in expanded closed cell PE-X. Provide with optional inlet and outlet low-lead brass full-port ball valves, NPT female x NPT female, for isolation, separately-sourced, Code NA108 series, with separately-sourced low-lead close nipples. Water and glycol solutions. Maximum percentage of glycol 50%. Maximum working pressure 150 psi (10 bar). Working temperature range 14 - 230° F (-10-110° C). Flow rate range unit of measurement gallons per minute (gpm). Accuracy ± 10%. Control stem angle of rotation 90°.

132 series with flanged connections

Balancing valve with flow meter. ANSI B16.1 CLASS 125 RF flanged connections 2 1/2", 3", and 4". Cast iron body. Brass ball. Brass ball control stem, chrome plated. R-PTFE ball seal seat. PTFE control stem guide. Brass flow meter body. Brass flow meter bypass valve stem, chrome plated. Stainless steel flow meter springs. PSU flow meter float and indicator cover. peroxide-cured EPDM seals. Water and glycol solutions. Maximum percentage of glycol 50%. Maximum working pressure 150 psi (10 bar). Working temperature range 14 - 230° F (-10-110° C). Flow rate range unit of measurement gallons per minute (gpm). Accuracy ± 10%. Control stem angle of rotation 90°.

We reserve the right to change our products and their relevant technical data, contained in this publication, at any time and without prior notice.



Caleffi North America, Inc.
 3883 W. Milwaukee Road
 Milwaukee, WI 53208
 Tel: 414-238-2360 · Fax: 414-238-2366
 sales@caleffi.com · www.caleffi.com
 © Copyright 2022 Caleffi North America, Inc.