

# Motorised zone valves

## Z-one™

series 642 - 643



01115/18 GB

replaces dp 01115/04 GB



### Function

The zone valves allow the automatic shut-off of circuits in heating and air conditioning systems.

The 642 (two-way) and 643 (three-way) zone valves series are equipped with a spring return actuator with a synchronous motor and auxiliary microswitch. They are therefore extremely versatile and suitable for use in both heating and air conditioning systems.

The actuator is fitted with a mechanism for rapidly clipping it onto the body of the valve which also makes it easy to remove.



### Product range

642 series Two-way motorised zone valve  
643 series Three-way motorised zone valve

sizes: 1/2", 3/4" and 1"  
sizes: 1/2", 3/4" and 1"

### Technical specification

#### Valve body

##### Materials:

- body: brass, EN 12165 CW617N  
- paddle stem: stainless steel  
- paddle: EPDM

##### Performance:

Medium: water, glycol solutions  
Max. percentage of glycol: 30%  
Temperature range: 0 – 90°C  
Peak temperature of fluid: 110°C  
Max. working pressure: 16 bar  
Connections: 1/2", 3/4", 1" F (ISO 228-1)

#### Actuator

##### Materials:

- base and cover: PC G10

##### Performance:

Synchronous motor: Normally closed  
Supply: 230 V - 50/60 Hz  
Power consumption: 6,5 W; 7 VA  
Opening time: 70 – 75 s  
Closing time: 5 – 7 s  
Microswitch contacts rating: 0,8 A  
Protection class: IP 20  
Max. ambient temperature: 40°C  
Complies with Directives: EN 60730-1 • EN 60730-2-14  
2014/35/EU • 2014/30/EU  
Length of power cable: 5x0,75 mm<sup>2</sup> - lunghezza 95 cm

### Ambient conditions (valve + actuator)

Medium working temperature range: 0÷90°  
Ambient temperature:  
Operation: 0÷40°C EN 60721-3-3 Cl. 3K3, max. humidity 85%  
Transportation: 20÷70°C EN 60721-3-2 Cl. 2K2, max. humidity 95%  
Storage: 5÷50°C EN 60721-3-1 Cl. 1K2, max. humidity 95%

### Dimensions

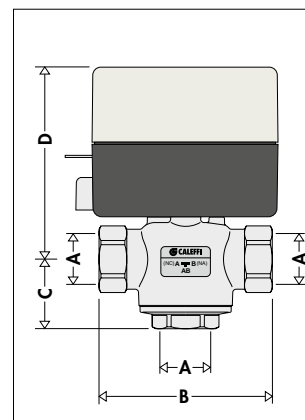
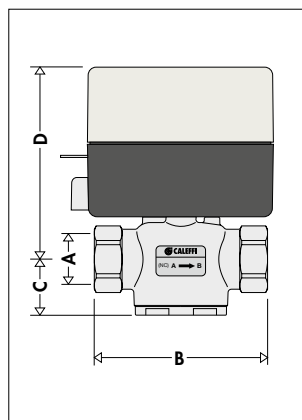

Code	A	B	C	D	Weight (kg)
642042	1/2"	78	24	90	0,97
642052	3/4"	78	24	94	0,98
642062	1"	88	24	94	1,10

Code	A	B	C	D	Weight (kg)
643042	1/2"	78	31,5	90	1,03
643052	3/4"	78	31,5	94	1,05
643062	1"	88	46,5	94	1,20

## Operating principle

With the electrical supply off, the actuator keeps the valve in the closed position. When an ambient temperature thermostat or other electrical device switches the supply on, the actuator moves the paddle into the open position.

When the supply is turned off, the valve closes again due to the action of a return spring.

## Valve operating states

	2 way	3 way
With supply OFF	Passage "A" closed	"A" closed "B" open "AB" open
With supply ON	Passage "A" open	"A" open "B" closed "AB" open
Opened manually	Passage "A" open	"A" open "B" open "AB" open

### 642 series 2-way zone valve

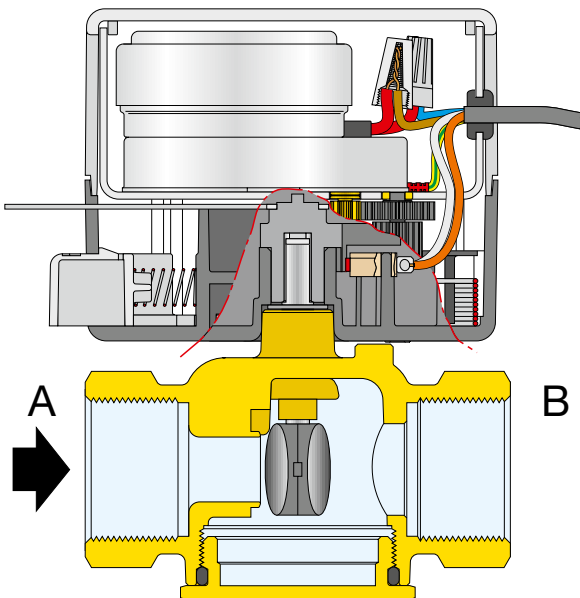

### 643 series 3-way zone valve

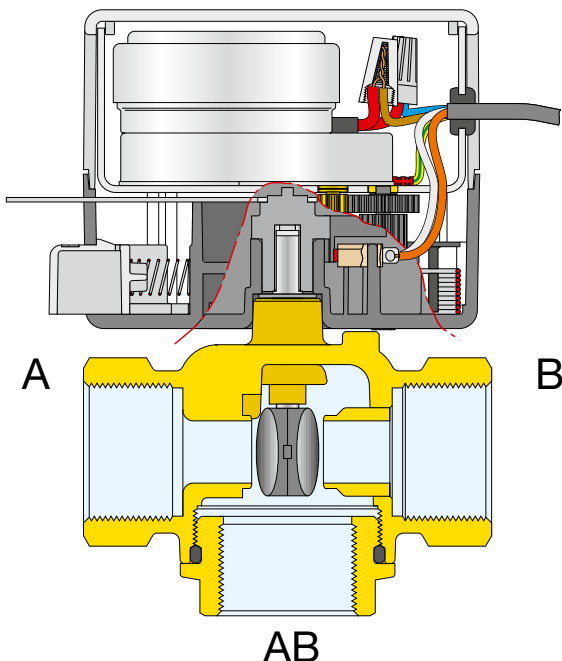

## Construction details

### • Auxiliary microswitch

The actuator is fitted with a microswitch to operate devices such as, for example, a circulating pump. The microswitch comes on when the valve is 60% open.

### • Manual opening

The valve can be opened manually by moving the lever to lock open position. When the power is restored the manual control is automatically overridden.

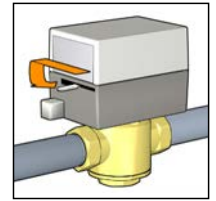

### • Clip on actuator

A rapid clip-on system makes it easy to remove it from the body of the valve for maintenance or replacement operations. Warning: the actuator can only be used with valve bodies 642 and 643 series.

### • Operation

The actuator is fitted with a special mechanism for gradual movement of the valve paddle which prevents judder and vibration due to the inertia of the gearmotor.

## Hydraulic characteristics

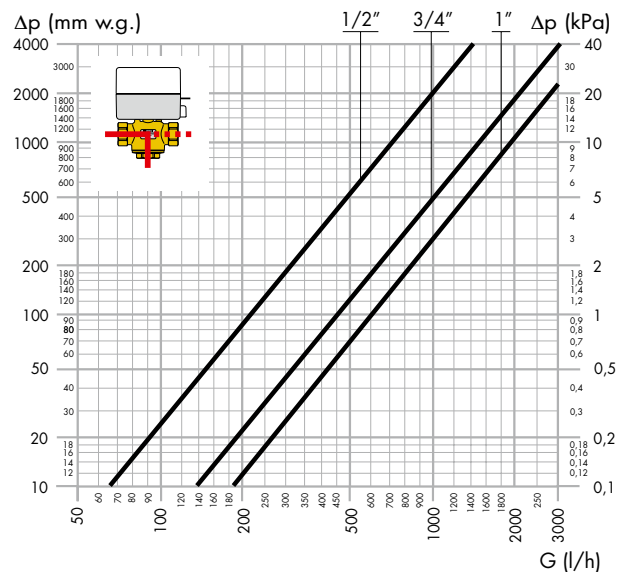
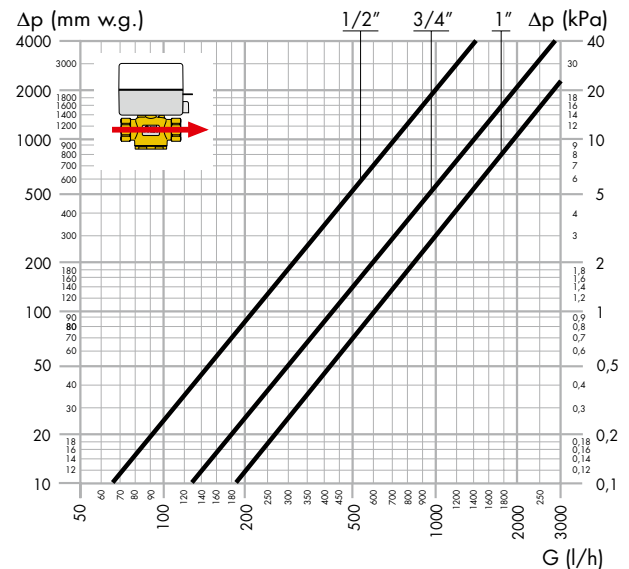

Connection	Kv (m³/h)		Max. differential pressure (kPa)
	(2-way)	(3-way)	
1/2"	2,5	2,5	210
3/4"	4,5	4,5	150
1"	6	6	100

## Installation

- The valve can be fitted either vertically or horizontally, with the actuator in any position, **except upside down**.

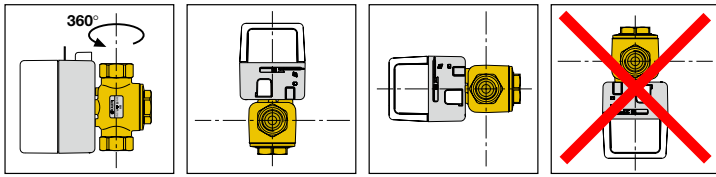

- When installed inside a casing it is important to ensure that there is adequate ventilation inside the casing itself.
- The three-way valve cannot be transformed into a two-way valve and vice versa.
- When zone valves are installed, the correct direction of flow must be observed as shown in the diagrams below.
- Two-way zone valves can be installed on both the flow and return sides; the direction of flow indicated by the arrow on the body of the valve must be observed.

### 2-way

(with the power OFF, passage A is closed)

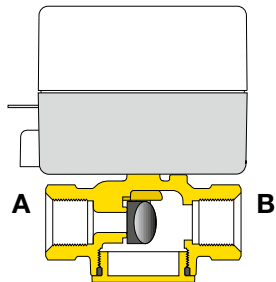
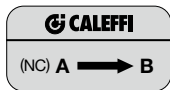

### 2-way installed on the flow side

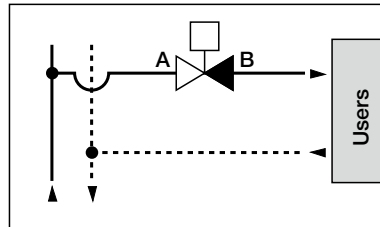

### 2-way installed on the return side

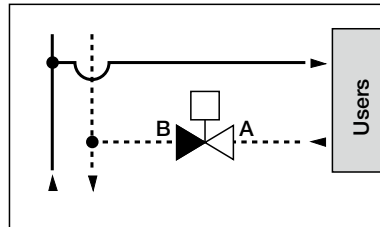

### 3-way

(with the power OFF, passage A is closed)

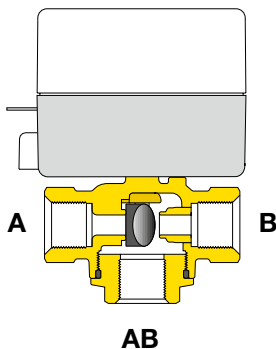

### 3-way installed on the flow side with diverter position and ON/OFF services

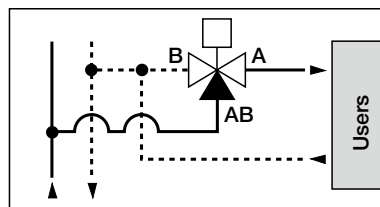

### 3-way installed on the return side with mixer position and ON/OFF services

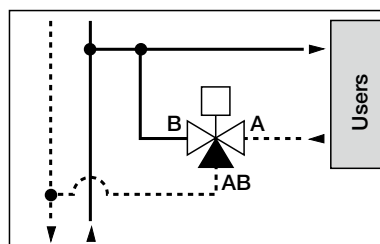

## Removal of the actuator

1. Set the lever on the side of the actuator to the open position (or to manual opening).
2. Press the open button on the side of the actuator and remove the actuator.

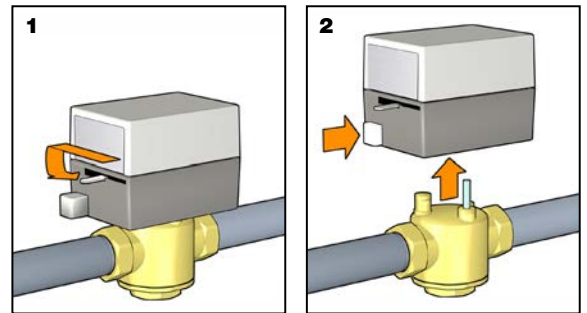

## Fitting of the actuator

1. Set the lever on the side of the actuator to the open position (or manual opening).
2. Check that the actuator is correctly positioned with respect to the valve as determined by the different dimensions of the operating stem and the locking pin.
3. Press the open button fully down. Clip on the actuator and release the button.

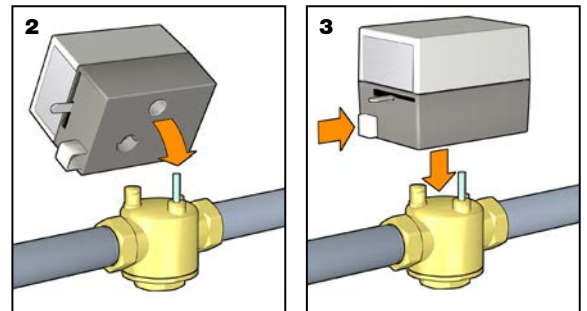

## Electrical connections

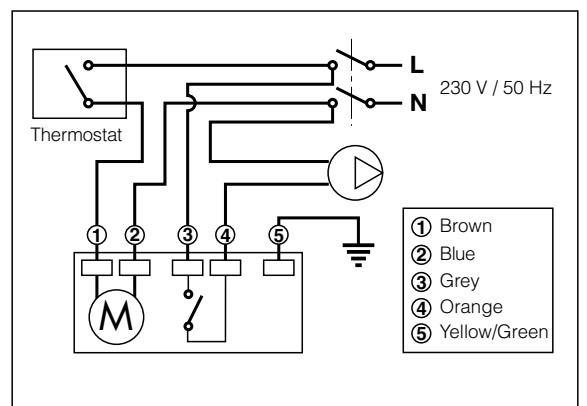

## Application diagram

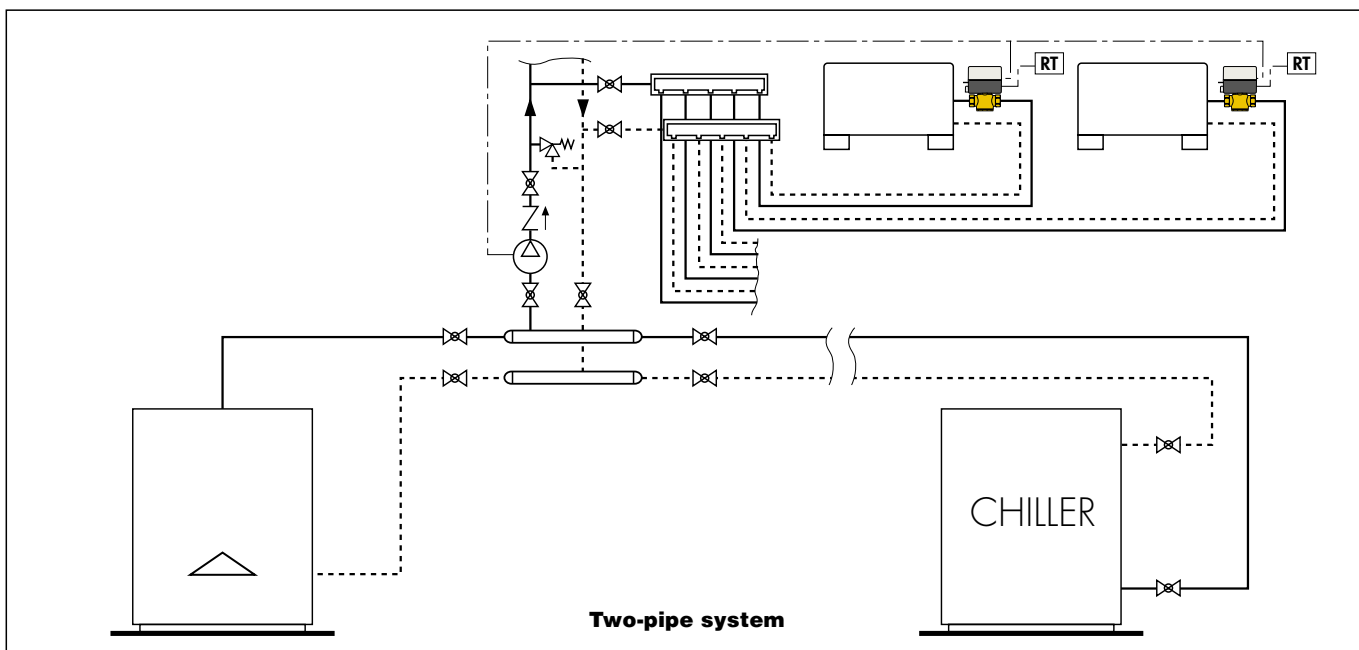
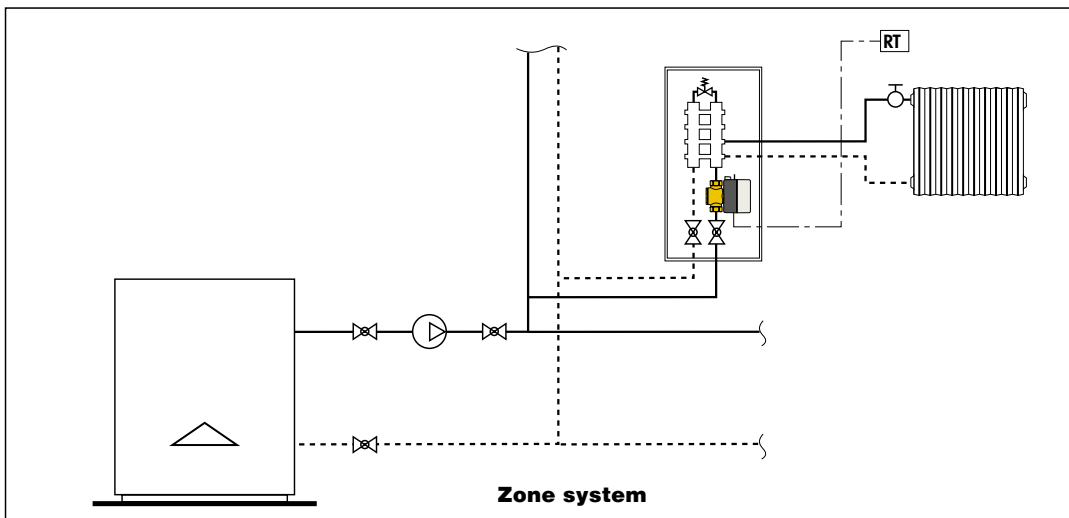
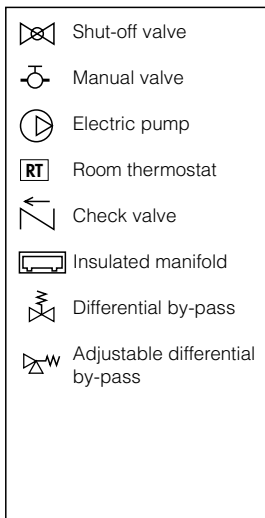

## SPECIFICATION SUMMARIES

### 642 series

Two-way motorised zone valve. Threaded connections 1/2" F (from 1/2" to 1") (ISO 228-1). Brass body. Valve stem in EPDM. Cover in reinforced polycarbonate. Temperature range: 0-90°C. Peak temperature of fluid: 110°C. Maximum working pressure: 16 bar. Maximum differential pressure: 210 kPa (1/2": 210 kPa, 3/4": 150 kPa, 1": 100 kPa). Maximum percentage of glycol: 30%. Actuator: Voltage 230 V (ac). Power consumption: 6,5 W; 7 VA. Maximum ambient temperature: 40°C. Opening time: 70 - 75 s. Closing time: 5 - 7 s. Fitted with auxiliary microswitch, contacts rating: 0,8 A. Protection class: IP 20.

### 643 series

Three-way motorised zone valve. Threaded connections: 1/2" F (from 1/2" to 1") (ISO 228-1). Brass body. Valve stem in EPDM. Cover in reinforced polycarbonate. Temperature range: 0-90°C. Peak temperature of fluid: 110°C. Maximum working pressure: 16 bar. Maximum differential pressure: 210 kPa (1/2": 210 kPa, 3/4": 150 kPa, 1": 100 kPa). Maximum percentage of glycol: 30%. Actuator: Voltage 230 V (ac). Power consumption: 6,5 W; 7 VA. Maximum ambient temperature: 40°C. Opening time: 70 - 75 s. Closing time: 5 - 7 s. Fitted with auxiliary microswitch, contacts rating: 0,8 A. Protection class: IP 20.

*We reserve the right to make changes and improvements to the products and related data in this publication, at any time and without prior notice.*