

Adjustable thermostatic mixing valve for high flow rates

524 series



Function

The thermostatic mixing valve is used in heating systems with centralised hot water production. It is designed to keep the temperature of the mixed water supplied to the user circuits constant when there are variations in the temperature of the water contained within the storage. It is designed for direct connection to the recirculation circuit. The materials used and high flow rate offered are central factors in achieving the desired thermal performance and reliability levels.

Product range

524 series Adjustable thermostatic mixing valve for high flow rates

sizes DN 65 and DN 80

Technical specifications

Materials

Body: bronze
Obturator: stainless steel

Performance

Adjustment temperature range: 36–53°C
Accuracy: ±2°C
Factory setting: 48°C
Max. working pressure: 10 bar
Max. inlet temperature: 90°C

Flanged connections: DN 65 and DN 80

Dimensions

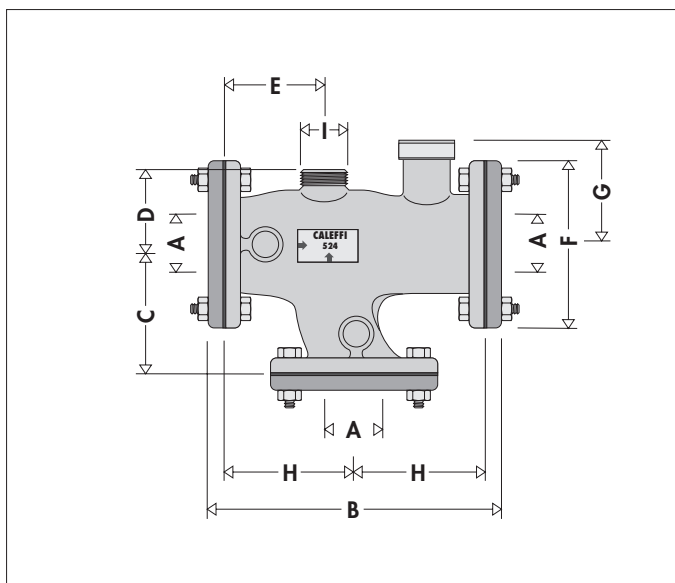

Code	A	B	C	D	E	F	G	H	I	Mass (kg)
524060	DN 65	330	145	82	112	∅ 185	121	145	1 1/2"	31
524080	DN 80	355	155	92	124	∅ 200	127	155	2"	36

Hydraulic characteristics

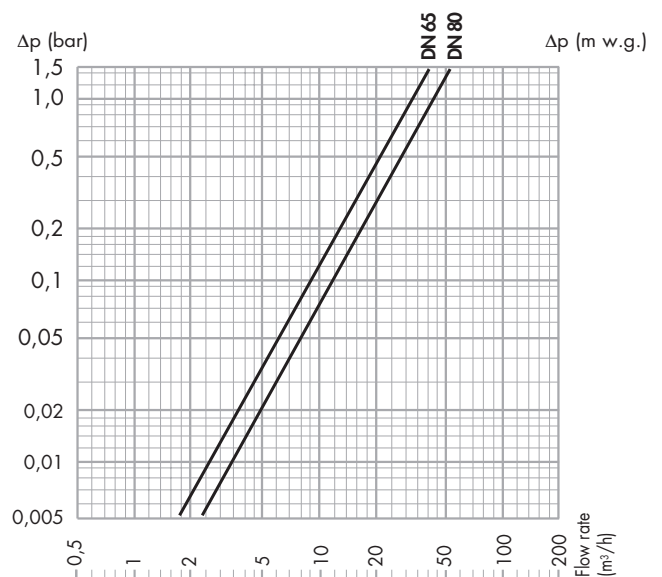

Code	∅	Kv
524060	DN 65	32
524080	DN 80	43

Operating principle

The (hot and cold) water proportions are regulated by a double obturator that slides inside a special cylinder placed between the hot and cold water passage channels.

For optimal regulation, make sure that the two inlet pipe pressures are aligned.

The recirculation circuit is easy to construct, thanks to the shut-off system for both the cold and hot water.

Maximum silent operation and minimal head losses.

Check valves

In systems with thermostatic mixing valves, check valves must be installed to prevent undesired backflow.

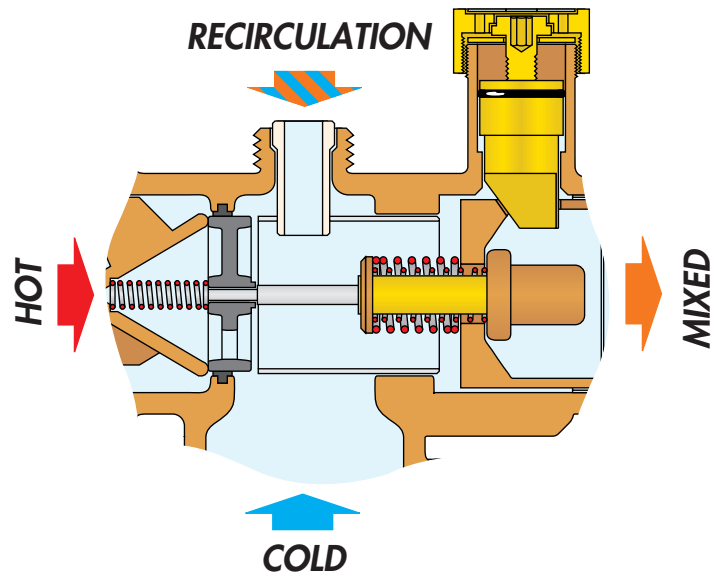

Regulation and recirculation

The check valve (1) prevents undesired circulation from the hot water storage.

The balancing valve (2) should be opened until the temperature of the mixed water being recirculated reaches the desired value

(which cannot exceed the setting value) during periods when no water is drawn.

If, after carrying out the procedure described in point 2, it is not possible to guarantee the stability of the desired temperature whether or not water is being drawn by the users, valve (3) must be set to a Δp greater than the value set for valve (2).

Application diagram

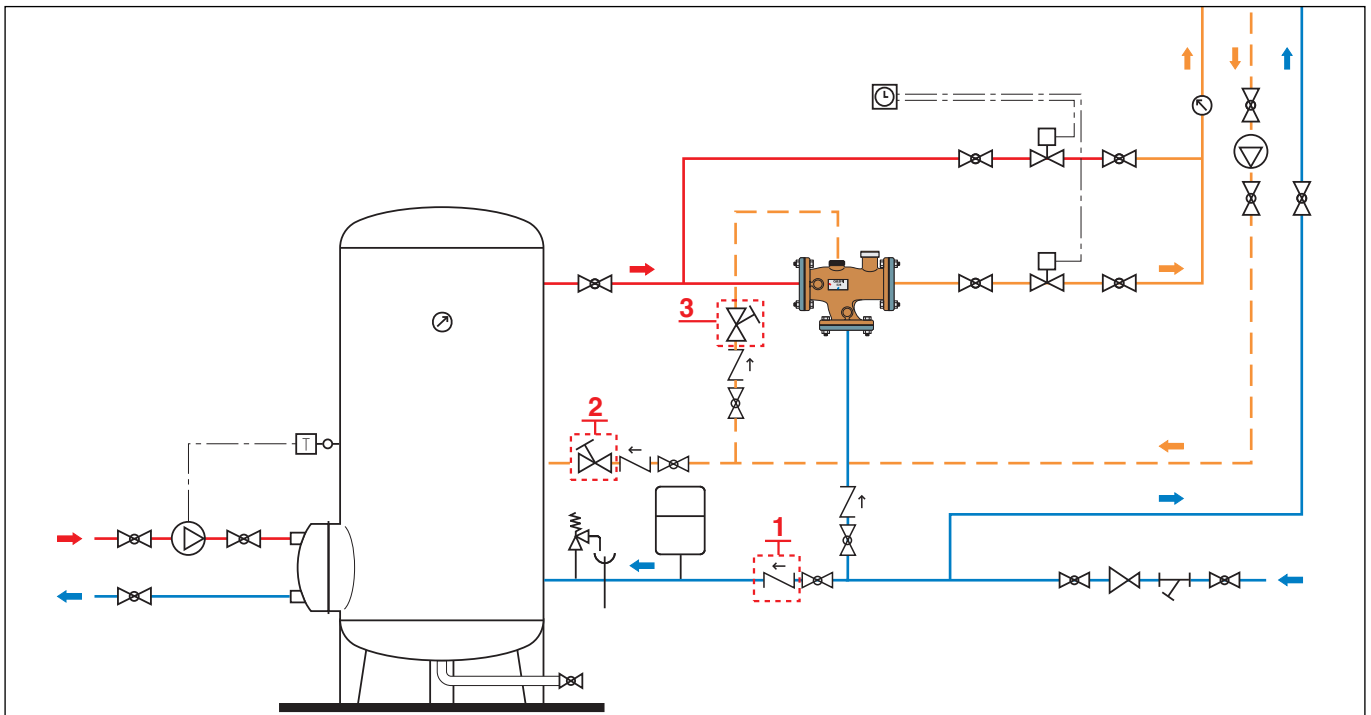

SPECIFICATION SUMMARY

524 series

Adjustable thermostatic mixing valve for high flow rates. Flanged connections DN 65 (and DN 80). Bronze body. Adjustment temperature range 36-53°C. Accuracy ± 2 . Factory setting 48°C. Maximum working pressure 10 bar. Maximum inlet temperature 90°C.

We reserve the right to change our products and their relevant technical data, contained in this publication, at any time and without prior notice.



CALEFFI S.p.A. · S.R.229, N.25 · 28010 Fontaneto d'Agogna (NO) · Italy · Tel. +39 0322 8491 · Fax +39 0322 863723
· www.caleffi.com · info@caleffi.com ·