

# Temperature relief valve with automatic filling



01058/19 GB

replaces 01058/07 GB

## 544 series



### Function

The dual effect temperature relief valve is used to ensure safety in heating systems that use a solid fuel boiler or residential device (fireplace heating system, thermostove, thermocooker) with a heat output below 35 kW as a heat generator without an emergency heat exchanger.

Within a single block, the device integrates a heat discharge valve and a filling valve that operate simultaneously and are controlled by a remote positive safety sensor. When the valve intervenes, refilling ensures water circulation as the fuel is running out, thereby protecting the integrity of the generator.

### Product range

Code 544400 Temperature relief valve with automatic filling \_\_\_\_\_ size 1/2"

### Technical specifications

#### Materials

Body: brass EN 12165 CW617N, chrome plated  
 Pocket: brass EN 12164 CW614N  
 Spring: steel EN 10270-1  
 Hydraulic seals: EPDM

#### Performance

Medium: water, glycol solutions  
 Maximum percentage of glycol: 30 %  
 Maximum working pressure: 6 bar  
 Setting temperature: 100 °C (+0 °C/-5 °C)  
 Working temperature range: 5–110 °C  
 Ambient temperature range: 1–50 °C  
 Discharge flow rate at 1 bar Δp: 1600 l/h

Connections: 1/2" F  
 Probe pocket connection: 1/2" M

Capillary length: 1300 mm

### Dimensions

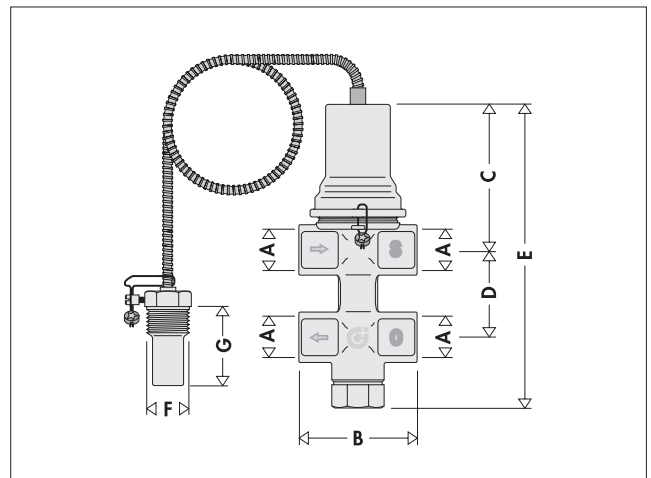

Code	A	B	C	D	E	F	G	Mass (kg)
544400	1/2"	60	77	50	162	1/2"	43	1,32

## Operating principle

When the setting temperature is reached, **(Fig.1)** the cold water inlet aperture is opened (flow from 4 to 3) and the drain aperture is opened simultaneously (flow from 1 to 2), until the temperature drops to below the trigger value and the inlet and drain close simultaneously. In the event of a malfunction in the sensitive element (5) (6), the valve will perform the same functions described above in a continuous manner.

The thermometric label (7) on the sensor indicates if the maximum permissible temperature of 110 °C has been exceeded.

The following are marked on the valve body **(Fig.2)**:

- arrow indicating the arrival point of the generator pipes on the flow pipe (1) and connection to the safety drain with letter "S" (2).
- arrow indicating flow to the generator (3) and the mains water system inlet with letter "C" (4).

**IMPORTANT: it is not possible to reverse the flows, always follow the filler and drain indications on the valve.**

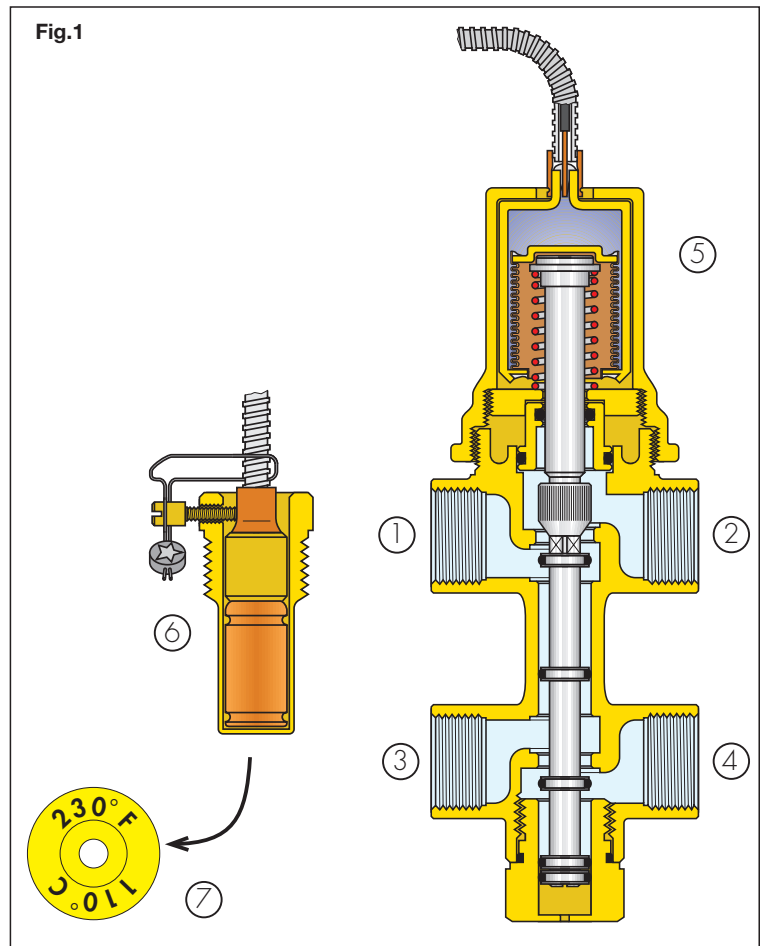
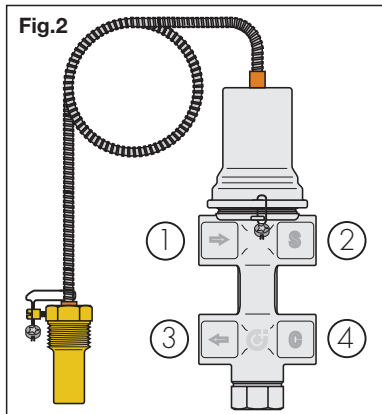

## Installation

The valve can be fitted in any position, vertical, horizontal or upside down.

The temperature probe pocket (6) supplied together with the valve must be fitted on the flow pipe at a distance (d) from the generator as specified by the current legislation, or at the highest point of the generator, and anyhow before the drain pipe. The pocket provided with the valve must be used.

In order to have better control over the inlet pressure, it is advisable to have a charging unit (normally open) on the valve filler pipe, set at the system operating pressure. When operating with an open vessel system, the entire system is charged directly through the pipe connected to the vessel.

In order to avoid any kind of malfunction due to the presence of debris, it is advisable to install an inspectable Y-strainer on the filling inlet. It is necessary to check periodically that the strainer is clean and not clogged.

It is advisable to install a low pressure drop strainer, fitted with devices to check the state of cleanliness to allow a functional check during operation (e.g. pressure gauges upstream and downstream of the filtering element).

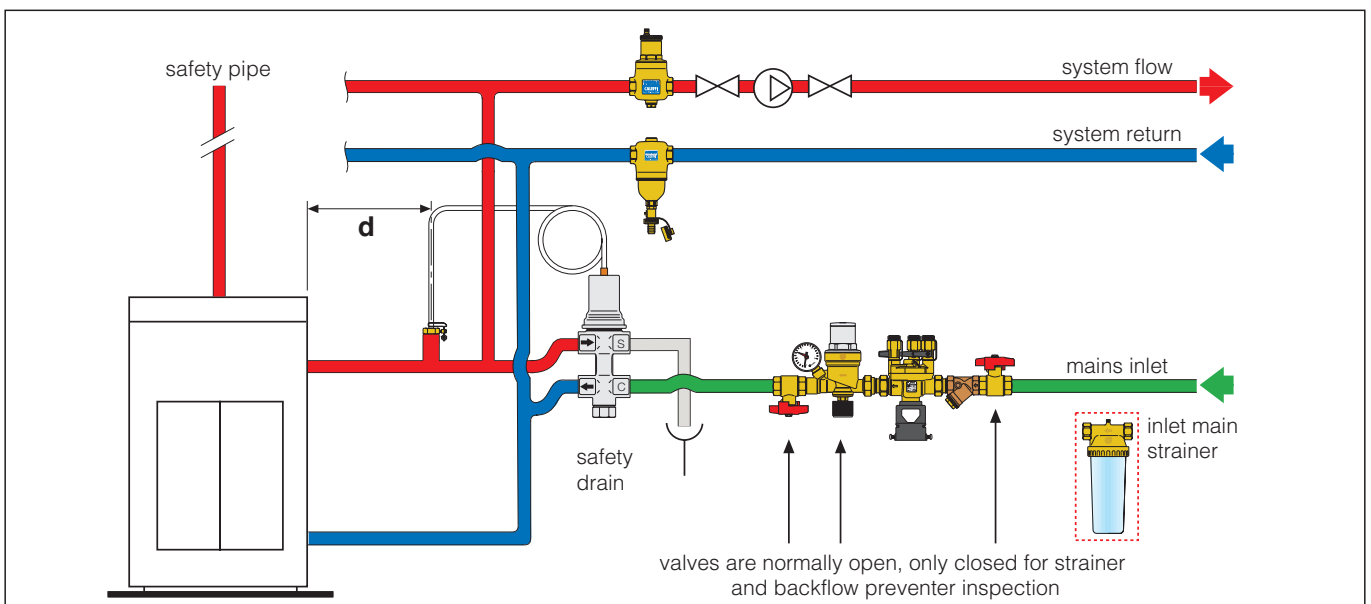

## System accessories

### 551 DISCAL®

tech. broch. 01060



Code

551005	3/4"
551006	1"
551007	1 1/4"
551008	1 1/2"
551009	2"

Deaerator.  
Brass body.  
**Threaded female connections.**  
**With drain.**  
Maximum working pressure: 10 bar.  
Working temperature range: 0–110 °C.  
PATENT.

#### Function

Deaerators are used to continuously discharge air from the hydraulic circuits of heating and air conditioning systems. The air discharge capacity of these devices is very high. They are capable of automatically removing all the air from the system down to micro-bubble level. Circulating fully deaerated water allows systems to operate under optimal conditions, free from any noise, corrosion, localised overheating or mechanical damage.

### 5462 DIRTCAL®

tech. broch. 01137



Code

546205	3/4"
546206	1"
546207	1 1/4"
546208	1 1/2"
546209	2"

Dirt separator.  
Brass body.  
**Threaded female connections.**  
Drain cock with hose connection.  
Top connection with plug.  
Maximum working pressure: 10 bar.  
Working temperature range: 0–110 °C.  
Particle separation rating: down to 5 µm.  
PATENT.

#### Function

Circulating water containing impurities in heating and air conditioning systems may result in rapid wear and damage to components such as pumps and control valves. It also causes clogging in heat exchangers, heating elements and pipes, resulting in lower thermal efficiency within the system. The dirt separator separates off these impurities, which are mainly made up of sand and rust particles. They are collected in a large collection chamber that can be cleaned infrequently, and from which they can be removed even while the system is in operation. This device is capable of efficiently removing even the smallest particles, with a very low pressure drop.

### 553

tech. broch. 01061



Code

553540	1/2" with pressure gauge connection
553640	1/2" with pressure gauge

Pre-adjustable automatic filling unit, anti-scale, inspectionable with pressure setting indicator. Complete with manual cock, strainer and check valve.

Adjustment range: 0,2–4 bar.  
Maximum inlet pressure: 16 bar.  
Maximum working temperature: 65 °C.

#### Function

The automatic filling unit is a device composed of a pressure reducing valve with compensating seat, inlet strainer, shut-off cock and check valve. It is installed on the water inlet pipe in closed circuit heating systems, and its main function is to keep the pressure of the system stable at a set value by automatically topping up with water as required. After installation, during filling or topping-up, the water supply will stop when the set pressure is reached.

## Application diagrams

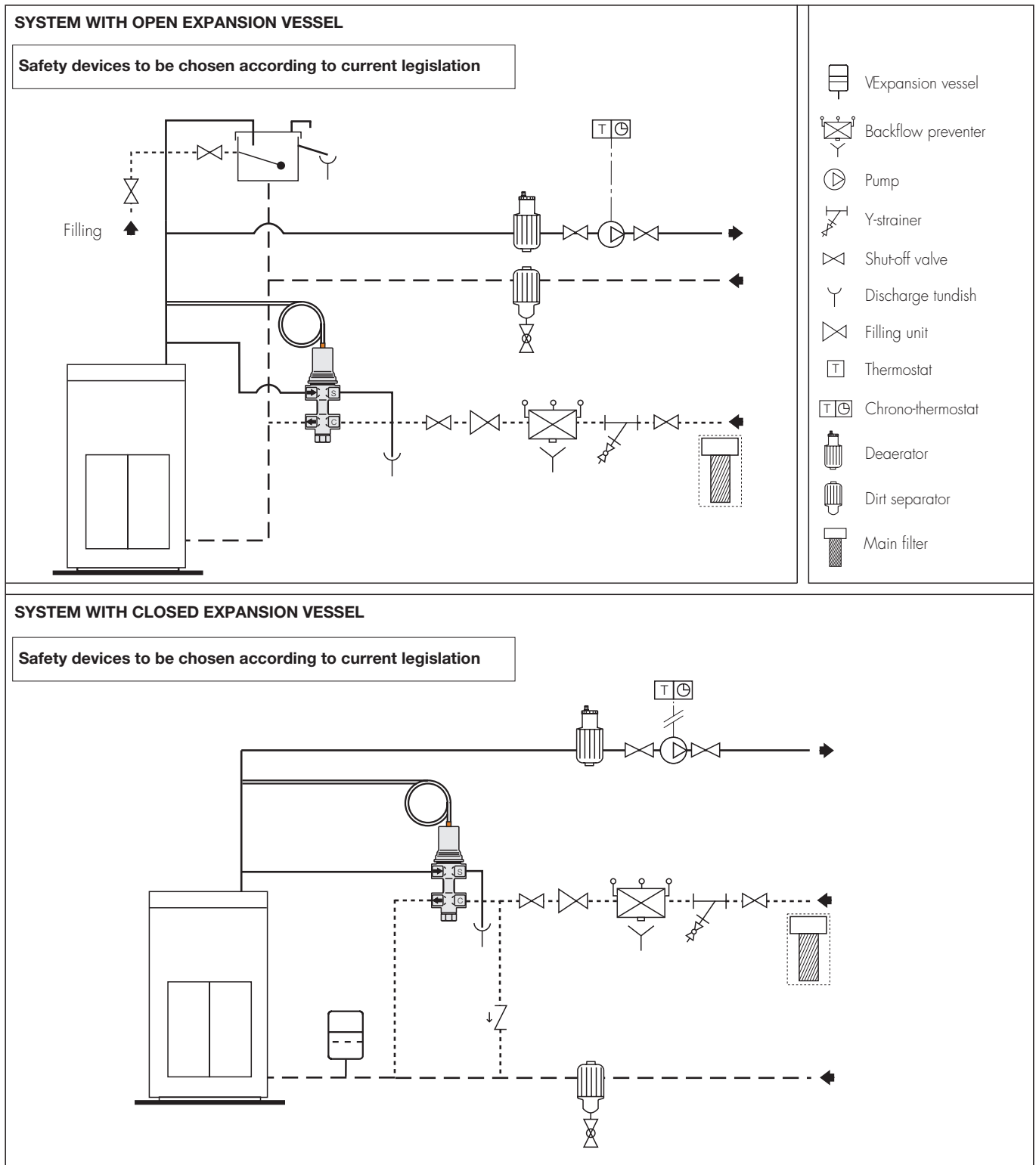

## SPECIFICATION SUMMARY

### 544 Series

Temperature relief valve with automatic filling. 1/2" F connections. Chrome plated brass body. Steel spring. Brass pocket. EPDM seals. Medium: water, glycol solutions. Maximum percentage of glycol 30 %. Maximum working pressure 6 bar. Setting temperature 100 °C (0–5 °C). Working temperature range 5–110 °C. Ambient temperature range 1–50 °C. Discharge flow rate 1 bar  $\Delta p$  1600 l/h. Complete with remote probe with pocket. Connection 1/2"M. Capillary length 1300mm.

We reserve the right to make changes and improvements to the products and related data in this publication, at any time and without prior notice.