

Ball valves with built-in check valve

3230 - 332 - 333 - 334 - 327 series

BALLSTOP



Function

The BALLSTOP ball valves with built-in check valve combine two devices in a single body: a ball shut-off cock and a check valve located inside the ball. The dual function allows quicker installation; the device is also more compact, thus reducing the amount of space required on the pipe.

BALLSTOP valves are available in two versions for two different uses: a version with a black plastic outer ring for use in domestic water systems and a version with a red outer ring for heating systems.



Product range

3230 series	Ball valve with built-in check valve, butterfly handle	_____	sizes 1/2"-1"
3230 series	Ball valve with built-in check valve, lever handle	_____	sizes 1"-2"
Code 332400	Ball valve with built-in check valve, butterfly handle	_____	size 1/2"
333 series	Ball valve with built-in check valve, butterfly handle	_____	sizes 1/2" and 3/4" x 3/4"
334 series	Ball valve with built-in check valve, butterfly handle	_____	sizes 1/2" and 3/4" x 3/4"
327 series	Ball valve with built-in check valve, butterfly handle	_____	sizes 1/2" and 3/4"
327 series	Ball valve with built-in check valve, lever handle	_____	sizes 1"-2"

series	3230 - 332 - 333 - 334	327
Materials Body: sizes 1/2"-2" Ball: sizes 1/2"-2" Check valve: size 1/2" size 3/4" sizes 1"-1 1/4" sizes 1 1/2"-2" Check valve spring: Check valve seal: Control device (lever/butterfly): Control stem seals:	brass EN 12165 CW617N brass EN 12164 CW617N, chrome plated PA POM PSU brass EN 12164 CW617N, chrome plated stainless steel NBR aluminium PTFE	brass EN 12165 CW617N brass EN 12164 CW617N, chrome plated PA POM PSU brass EN 12164 CW617N, chrome plated stainless steel EPDM aluminium PTFE
Performance Medium: Max. percentage of glycol: Max. working pressure: Check valve minimum opening pressure (Δp): Working temperature range:	water - 16 bar 0,02 bar 5-90 °C	water, glycol solutions 30 % 16 bar 0,02 bar 5-110 °C
Connections	3230 series: 1/2"-2" F Code 332400: 1/2" M x 1/2" F Code 333400: 1/2" F x 3/4" F nut Code 333500: 3/4" F x 3/4" F nut Code 334400: 1/2" M x 3/4" F nut Code 334500: 3/4" M x 3/4" F nut 333 and 334 series: drilled anti-tamper safety nut	1/2"-2" F

Dimensions

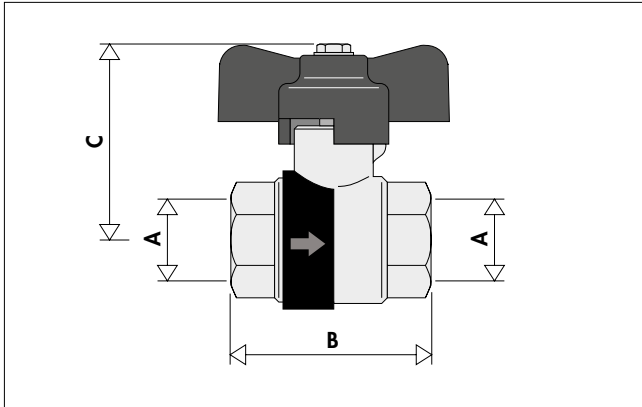

Code	Code	DN	A	B	C	Mass (kg)
323040	327400	15	1/2"	51	50,5	0,28
323050	327500	20	3/4"	57	52,5	0,37
323062		25	1"	70	61,5	0,55

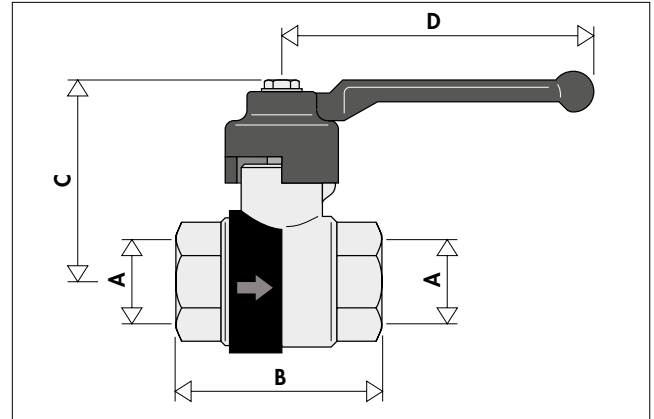

Code	Code	DN	A	B	C	D	Mass (kg)
323060	327600	25	1"	70	61,5	111	0,55
323070	327700	32	1 1/4"	83	65,5	111	1,01
323080	327800	40	1 1/2"	89	80	149	1,60
323090	327900	50	2"	110	89	149	2,80

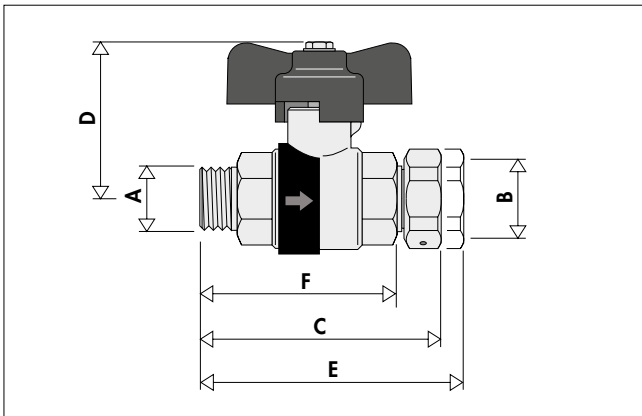

Code	DN	A	B	C	D	E	F	Mass (kg)
332400	15	1/2"	1/2"	-	50,5	-	61	0,40

334400	15	1/2"	3/4" calotta	63,5	50,5	70	-	0,40
334500	15	3/4"	3/4" calotta	69,5	52,5	73	-	0,42

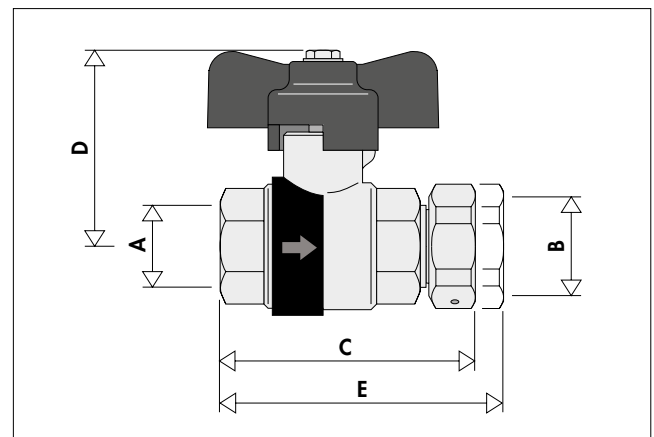

Code	DN	A	B	C	D	E	Mass (kg)
333400	15	1/2"	3/4" calotta	63,5	50,5	70	0,42
333500	20	3/4"	3/4" calotta	69,5	52,5	73	0,42

Operating principle

The valve consists of a ball (1) containing a suitably hydraulically-shaped check valve obturator (2). During normal circulation of the medium within the system, the obturator is pushed against the counter-spring (3) inside it, so as to open the channel to allow the medium to flow through. When the pressure downstream of the valve exceeds the upstream value, the obturator is pushed in the opposite direction, against the seal seat on the ball (4), in order to prevent medium back flow.

Plus, when there is no flow, the valve closes thanks to the action of the counter-spring.

The obturator, thanks to the thrust produced by the counter-spring (3) and the downstream pressure, completely shuts off the flow of medium through the specially shaped seal (5) (positioned on the ball seal seat or on the obturator, depending on the version).

The ball, equipped with a butterfly handle (6) or lever depending on the size of the valve, acts as a normal shut-off device.

3230 series

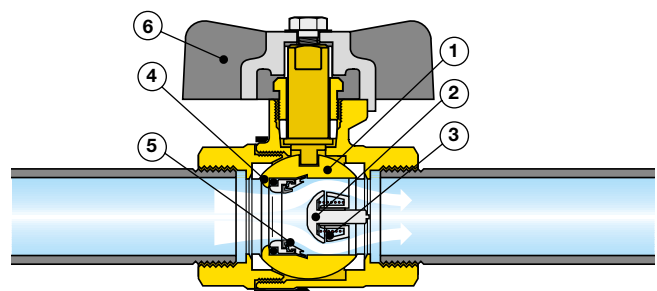

327 series

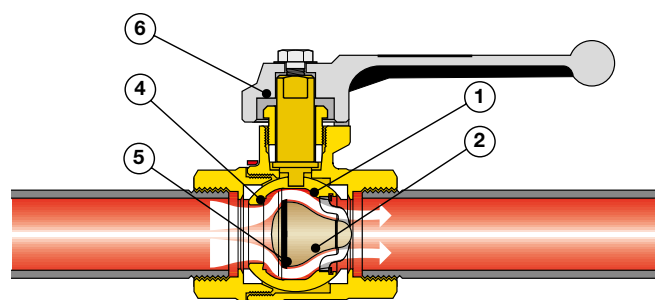

Construction details

Silent operation and low head losses

Thanks to the ogival hydraulic shape of the obturator, the BALLSTOP valve guarantees silent operation. Plus, the flow rate curve is particularly “flat”, demonstrating limited increases in head loss in response to significant increases in flow rate.

Quick operation

The gasket (positioned on the ball resting point or on the obturator itself, depending on the version) and the counter-spring (housed inside the obturator) ensure there are no delays in closure and guarantee an airtight seal, even when slight counter pressure is applied.

Non-sensitivity to impurities

The sliding parts, thanks to a special coupling, are not sensitive to small impurities in the water, or to the deposits which can form as a result of prolonged periods of inactivity.

Food-safe elastomers and other materials

The elastomers used in the seals and the other materials used for the 3230, 332, 333 and 334 series BALLSTOP products comply with the compatibility requirements for use with potable water as required by KIWA UK and ACS certifications.

Easier system startup and maintenance

During system startup or maintenance, or whenever it is necessary to reverse the flow direction through the valve, the check valve can be excluded by setting the lever to 45°; this allows the medium to flow through the channel between the outside of the ball and the valve body. This also allows any air pockets which have formed due to system inactivity to be released.

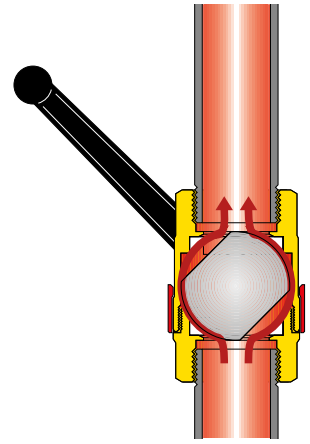

Hydraulic characteristics

3230 - 332 - 333 - 334 series

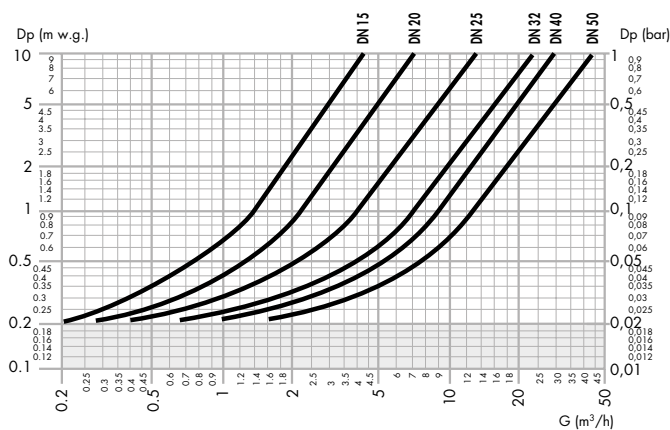

DN	15	20	25	32	40	50
Kv (m³/h)	4,2	7	13,5	24	29	43

327 series

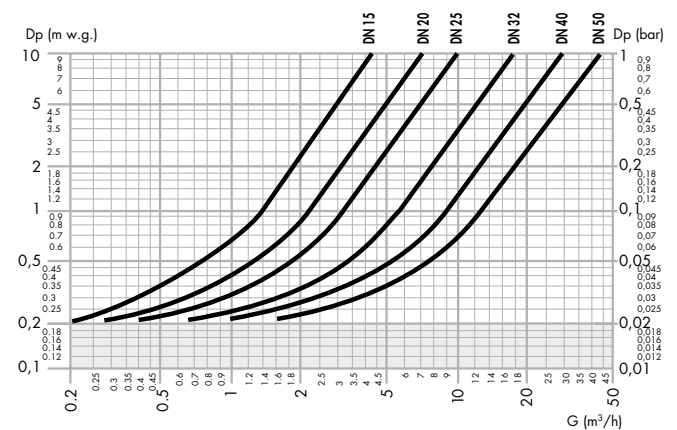

DN	15	20	25	32	40	50
Kv (m³/h)	4,2	7	10	18	29	43

Installation

The Caleffi 3230, 332, 333 and 334 series BALLSTOP ball valves with built-in check valve are designed for use **in domestic water systems** which require an interceptable check valve. Installation examples may include connection to the mains system, or on supply lines to the boiler, etc.

The Caleffi 327 series BALLSTOP ball valves with built-in check valve are designed for use **in heating systems**, as the materials used to make the seals are compatible with high operating temperatures. The application of a check valve after the pump (adjacent figure) is intended to prevent the convective motion of natural circulation which takes place while the circulation pump is off and which causes an unwanted temperature increase in the rooms, leading to higher costs and environmental issues for the user.

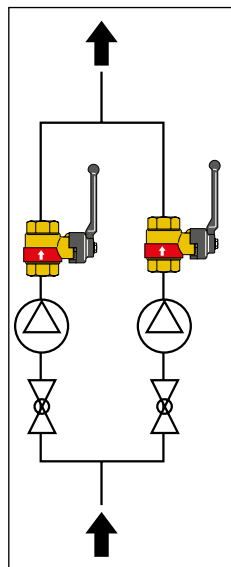

The ball valve, which houses the non-return device, actually carries out a shut-off function: if the pump is removed or the boiler emptied, it prevents all the water in the system from draining out.

The ball shut-off valve with built-in check valve should be installed in the system in accordance with the flow direction indicated on the plastic band applied to the valve body. The valve can be fitted in any position, horizontal, vertical, or upside down.

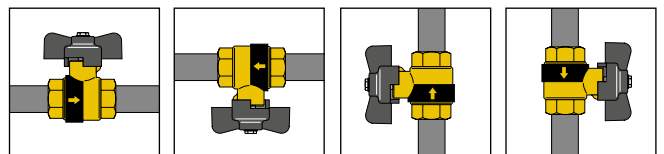

Application diagrams

Centralised domestic hot water production system with thermal disinfection

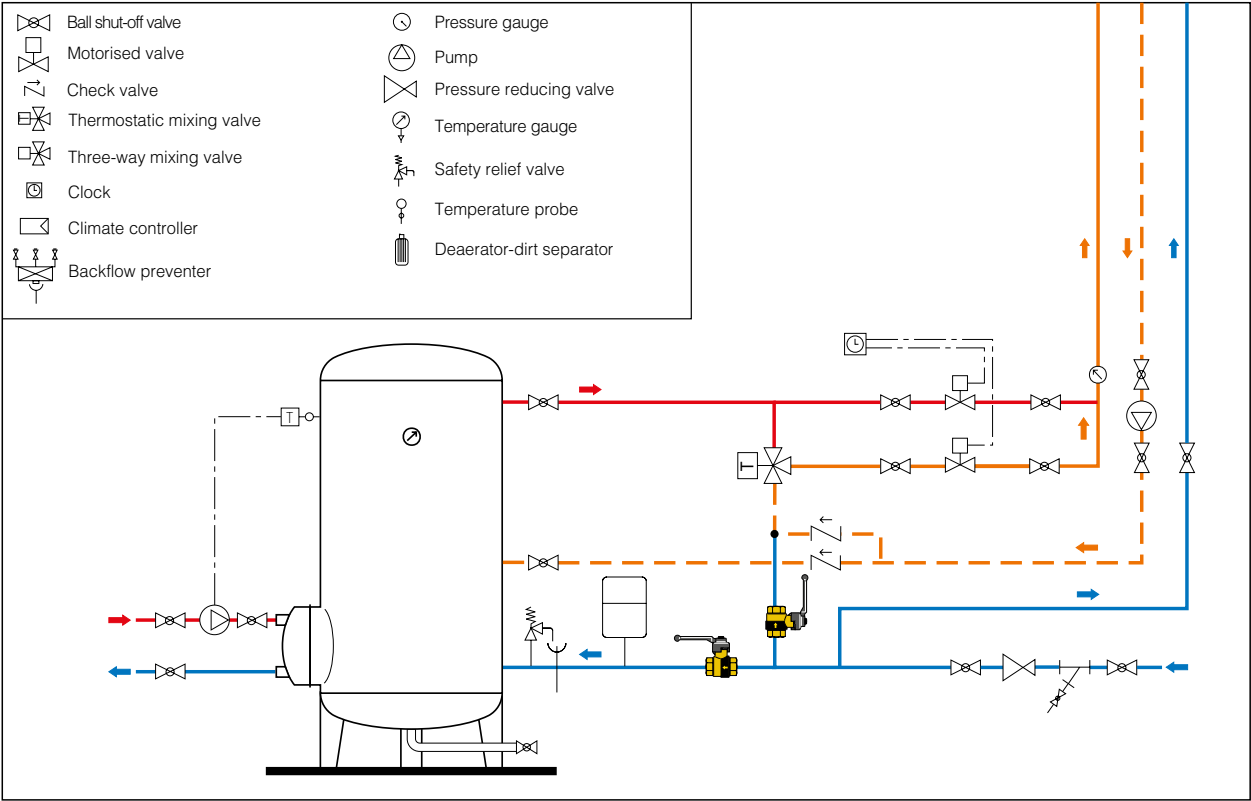

Solar system with thermal integration

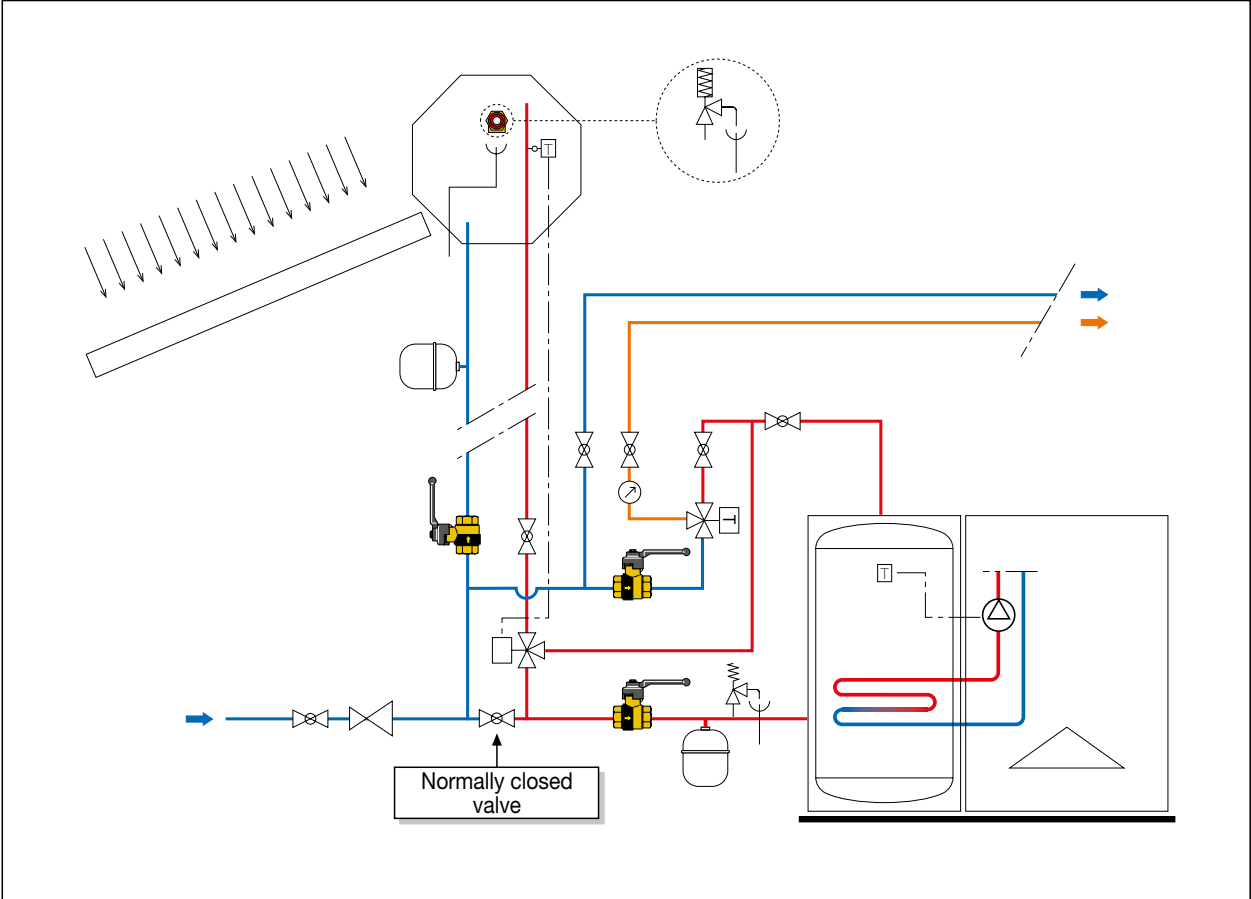

Heating system with two heat generators and different secondary circuits

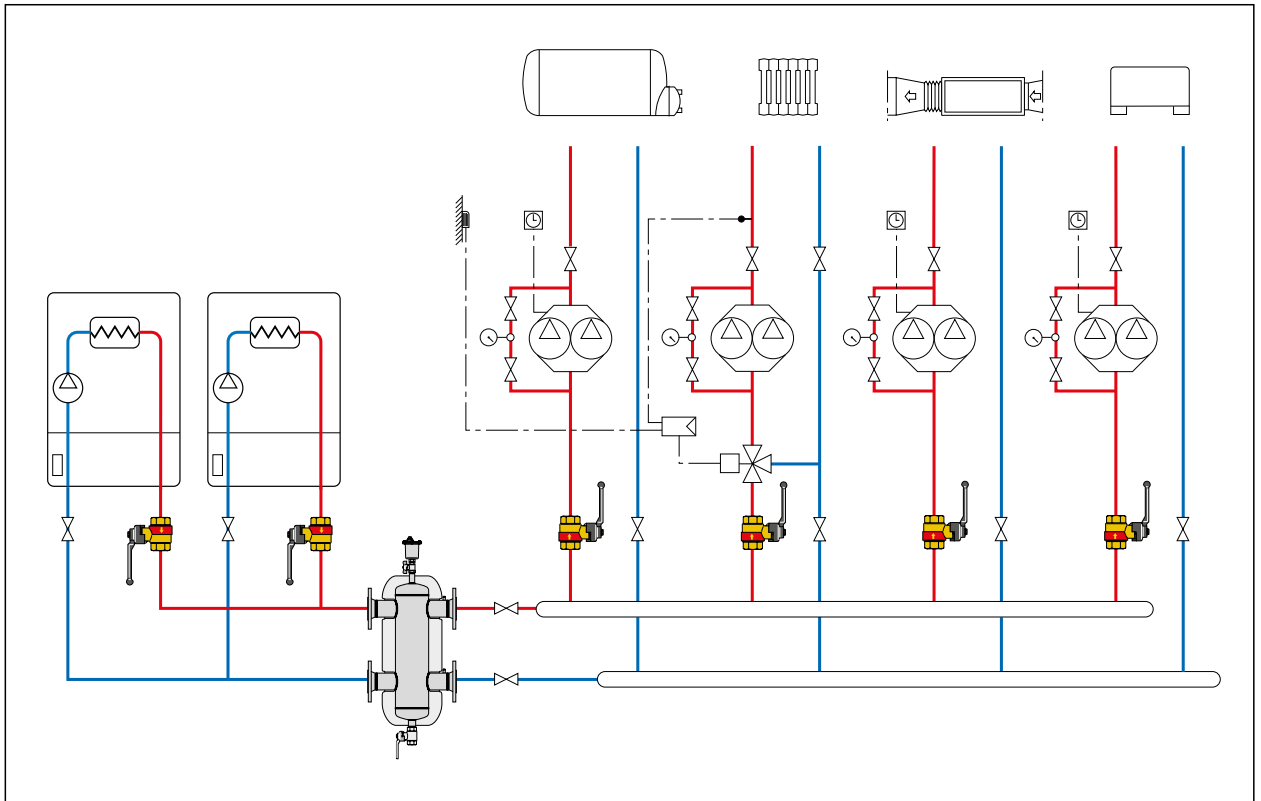

Heating system with one heat generator and different secondary circuits

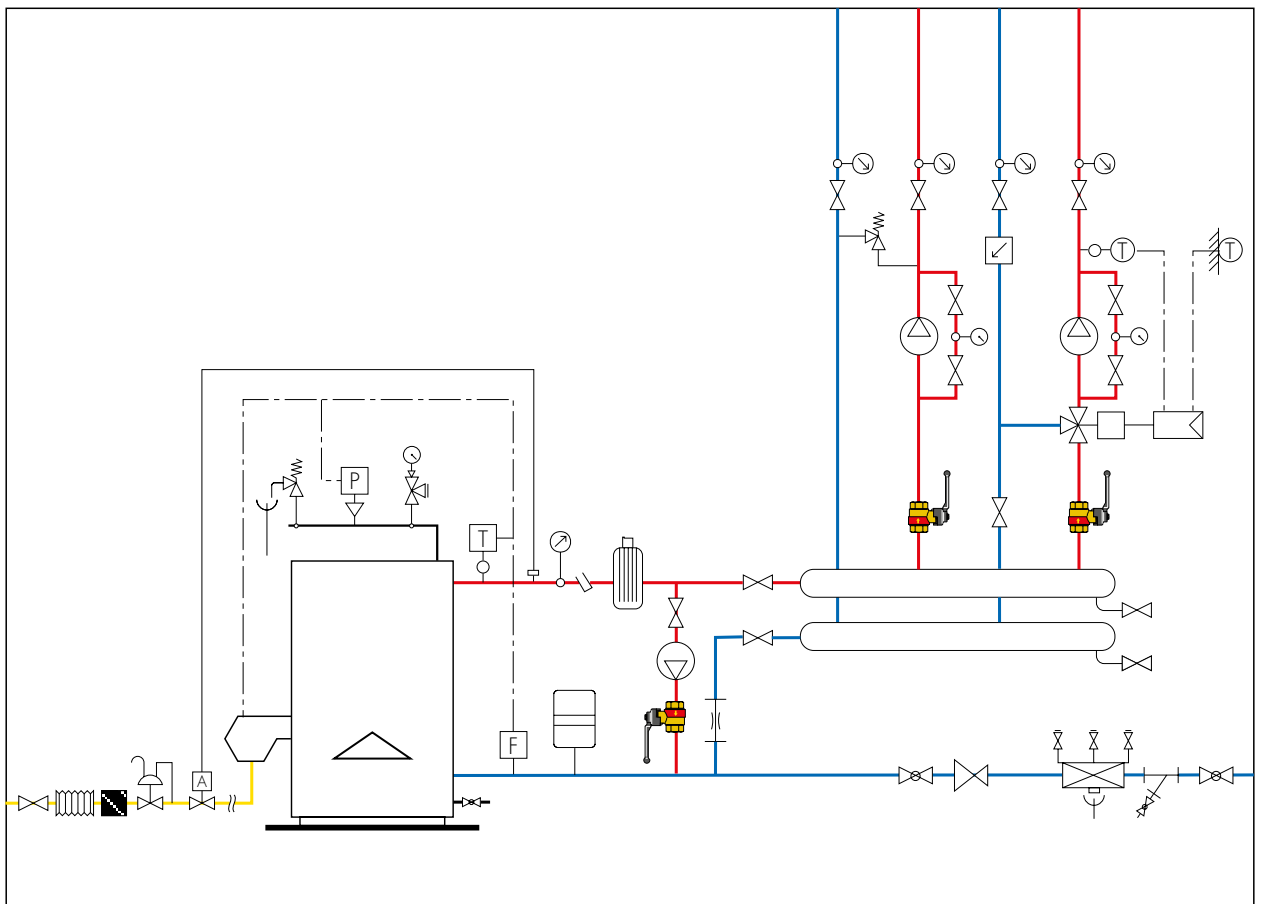

SPECIFICATION SUMMARY

3230 series BALLSTOP

Ball valve with built-in check valve. Butterfly handle. Threaded connections 1/2" (from 1/2" to 1") F. Brass body. Brass ball, chrome plated. Check valve in PA (1/2"), POM (3/4"), PSU (1"). Aluminium control lever. PTFE control stem seals. Check valve seal in NBR. Stainless steel check valve spring. Medium: water. Working temperature range 5–90 °C. Maximum working pressure 16 bar. Min. opening pressure for check valve 0,02 bar.

3230 series BALLSTOP

Ball valve with built-in check valve. Lever handle. Threaded connections 1" (from 1" to 2") F. Brass body. Brass ball, chrome plated. Check valve in PSU (1 1/4"), chrome plated brass (1 1/2" and 2"). Aluminium control lever. PTFE control stem seals. Check valve seal in NBR. Stainless steel check valve spring. Medium: water. Working temperature range 5–90 °C. Maximum working pressure 16 bar. Min. opening pressure for check valve 0,02 bar.

Code 332400 BALLSTOP

Ball valve with built-in check valve. Butterfly handle. Threaded connections 1/2" M x 1/2" F. Brass body. Brass ball, chrome plated. Check valve in PA. Aluminium control lever. PTFE control stem seals. Check valve seal in NBR. Stainless steel check valve spring. Medium: water. Working temperature range 5–90 °C. Maximum working pressure 16 bar. Min. opening pressure for check valve 0,02 bar.

333 series BALLSTOP

Ball valve with built-in check valve. Butterfly handle. Connections 1/2" (or 3/4") F x nut 3/4" F. Brass body. Brass ball, chrome plated. Check valve in PA (1/2"), POM (3/4"). Aluminium control lever. PTFE control stem seals. Check valve seal in NBR. Stainless steel check valve spring. Medium: water. Working temperature range 5–90 °C. Maximum working pressure 16 bar. Min. opening pressure for check valve 0,02 bar.

334 series BALLSTOP

Ball valve with built-in check valve. Butterfly handle. Connections 1/2" (or 3/4") M x nut 3/4" F. Brass body. Brass ball, chrome plated. Check valve in PA (1/2"), POM (3/4"). Aluminium control lever. PTFE control stem seals. Check valve seal in NBR. Stainless steel check valve spring. Medium: water. Working temperature range 5–90 °C. Maximum working pressure 16 bar. Min. opening pressure for check valve 0,02 bar.

327 series BALLSTOP

Ball valve with built-in check valve for heating systems. Butterfly handle. Connections 1/2" (or 3/4") F. Brass body. Brass ball, chrome plated. Check valve in PA (1/2"), POM (3/4"). Aluminium control lever. PTFE control stem seals. Check valve seal in EPDM. Stainless steel check valve spring. Medium: water, glycol solutions. Max. percentage of glycol 30 %. Working temperature range 5–110 °C. Maximum working pressure 16 bar. Min. opening pressure for check valve 0,02 bar.

327 series BALLSTOP

Ball valve with built-in check valve for heating systems. Lever handle. Connections 1" (from 1" to 2") F. Brass body. Brass ball, chrome plated. Check valve in PSU (1" and 1 1/4"), chrome plated brass (1 1/2" and 2"). Aluminium control lever. PTFE control stem seals. Check valve seal in EPDM. Stainless steel check valve spring. Medium: water, glycol solutions. Max. percentage of glycol 30 %. Working temperature range 5–110 °C. Maximum working pressure 16 bar. Min. opening pressure for check valve 0,02 bar.

We reserve the right to make changes and improvements to our products and the related technical data in this publication, at any time and without prior notice. The website www.caleffi.com always has the most up-to-date version of the document, which should be used for technical verifications.