

DIRTCAL® Dirt Separator

NA 5465 ASME & CRN Steel Series

Submittal Data 02926 NA — Issue Date 04/2011



Application

In heating and air conditioning control systems, the circulation of water containing impurities may result in rapid wear and damage to components such as pumps and control valves. It also causes blockages in heat exchangers, heating elements and pipes, resulting in lower thermal efficiency within the system. The dirt separator separates off these impurities, which are mainly made up of particles of sand and rust, collecting them in a large collection chamber, from which they can be removed even while the system is in operation. This device is capable of efficiently removing even the smallest particles, with very low head loss. Patented.

Typical Specification

Furnish and install on the plans and described herein, a Caleffi DIRTCAL® Dirt Separator as manufactured by Caleffi. Each separator must be designed with a blowdown drain port. The separator design must include a large internal volume, and a stainless steel internal screen to automatically remove all dirt present in the system with particle separating capacity to 5µm (0.2 mil). The separator must be constructed in accordance with the latest revision of the ASME Boiler and Pressure Vessel Code, CRN Registered, and stamped for 150 psi (10 bar) working pressure. (See product instructions for specific installation information.)

Technical Data

- Materials:
- Body: epoxy resin painted steel
 - Internal screen: Stainless steel
 - Seal: EPDM
- Suitable fluids: water, or 50% max. glycol solution
- Max working pressure: 150 psi (10 bar)
- Temperature range: 32–250°F (0–120°C)
- Particle separation capacity: to 5µm (0.2 mil)
- Connections:
- Flanged (ASME & CRN Registered): 2"–6" ANSI B16.5 Class 150 RF
 - Blowdown drain: 1" NPT male

Hydraulic Characteristics

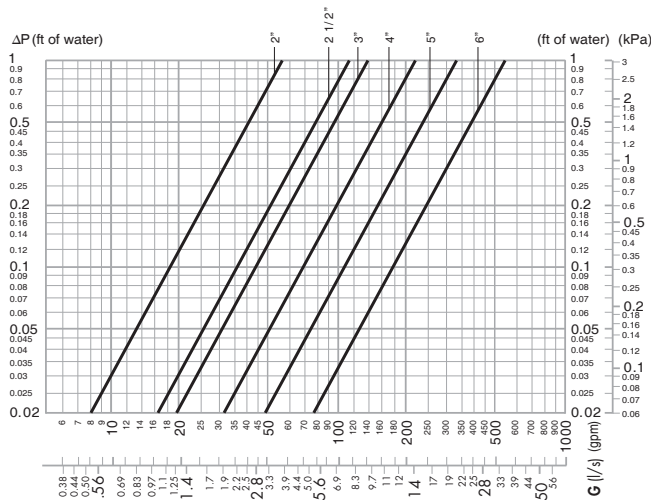

Dimensions

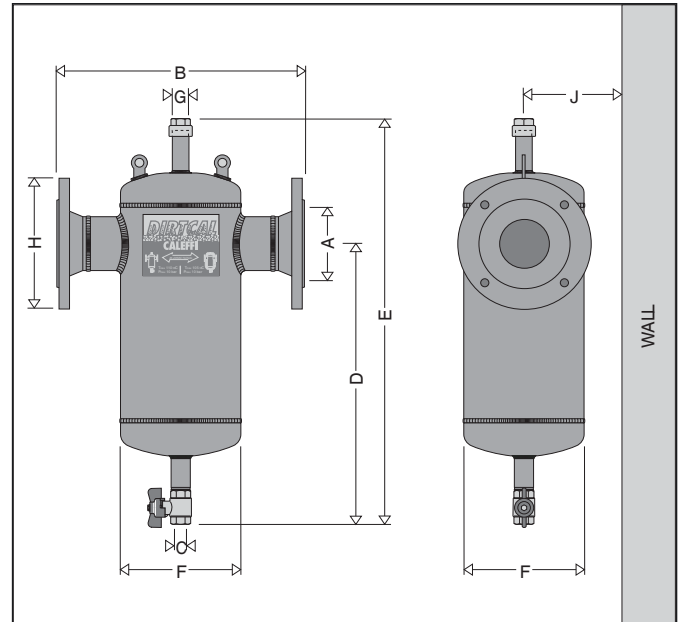

Code	A	B	C	D	E	F	G	H	J*	Weight (lb)	(kg)
NA546550A	2"	13 3/4"	1"	16 5/16"	23 7/8"	6 5/8"	3/4"	6"	6 5/16"	38	17
NA546560A	2 1/2"	13 3/4"	1"	16 5/16"	23 7/8"	6 5/8"	3/4"	7"	6 5/16"	38	17
NA546580A	3"	18 3/8"	1"	20 11/16"	30 5/8"	8 5/8"	3/4"	7 1/2"	7 5/16"	55	25
NA546510A	4"	18 1/2"	1"	20 11/16"	30 5/8"	8 5/8"	3/4"	9"	7 5/16"	55	25
NA546510A	5"	25"	1"	23 3/16"	34 15/16"	12 3/4"	3/4"	11"	9 3/8"	138	63
NA546515A	6"	25"	1"	23 3/16"	34 15/16"	12 3/4"	3/4"	11"	9 3/8"	148	67

*This dimension allows for a minimum of 3" wall clearance to accommodate insulation if used.

Vessel Volume

Size	2"	2 1/2"	3"	4"	5"	6"
Cap. (gal)	1.8	1.8	4.8	4.8	13.7	13.7
Cap. (l)	7.0	7.0	18.0	18.0	52.0	52.0

Flow Capacity

The maximum fluid velocity recommended at the unit connections is ~ 4 f/s. The following table shows the maximum flow rates to comply with this condition.

Size	Flow Capacity					
	2"	2 1/2"	3"	4"	5"	6"
GPM	37.0	62.0	94.0	148.0	259.0	376.0
L/ Sec.	2.3	3.9	5.9	9.3	16.3	23.7
Cv	88	176	211	328	520	842

We reserve the right to change our products and their relevant technical data, contained in this publication, at any time and without prior notice. Contractors should request production drawings if prefabricating the system.

Job name _____

Job location _____

Engineer _____

Mechanical contractor _____

Contractor's P.O. No. _____

Representative _____

Size _____

Quantity _____

Approval _____

Service _____

Tag No. _____

Notes _____