

Automatic flow rate regulator with high-resistance polymer cartridge

121 - 126 series

AutoFlow®

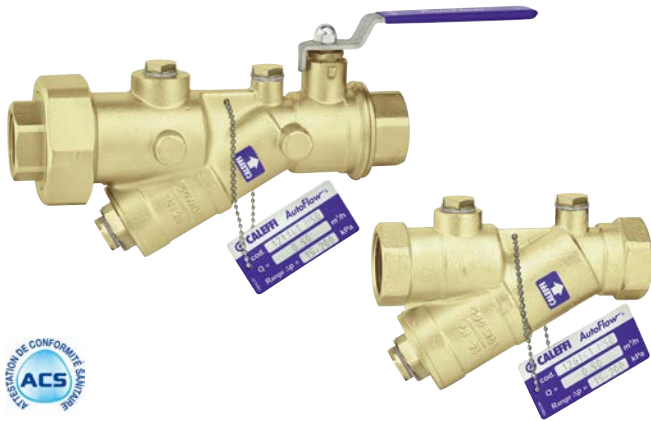

Function

The AUTOFLOW® devices are automatic flow rate regulators capable of maintaining a constant flow rate of the medium as the operating conditions of the hydronic circuit change. They automatically balance the hydronic circuit and ensure the design flow rate at each terminal emitter.

In this particular series, the devices are equipped with an innovative and exclusive regulator element made of high-resistance polymer, selected for use in air-conditioning and plumbing systems. With this new regulator, the devices provide silent operation, accuracy in control, insensitivity to scale and a long service life.

The devices are available in both the version as a flow regulator and in the version completed with a shut-off ball valve.

Product range

121 series Automatic flow rate regulator with high-resistance polymer cartridge and ball valve _____ sizes 1/2" - 3/4" - 1" - 1 1/4" - 1 1/2" - 2"
 126 series Automatic flow rate regulator with high-resistance polymer cartridge _____ sizes 1/2" - 3/4" - 1" - 1 1/4" - 1 1/2" - 2"

Technical specifications

series	121	126
Materials Body: AUTOFLOW® cartridge: - 1/2"-1 1/4" - 1 1/2" and 2" Spring: Hydraulic seals: Ball: Ball seat: Control stem seal: Lever: Pressure port plugs:	dezincification resistant alloy CR EN 12165 CW602N high resistance polymer stainless steel and high resistance polymer stainless steel EPDM brass EN 12165 CW614N, chrome plated PTFE PTFE special galvanized steel dezincification resistant alloy CR EN 12165 CW602N	dezincification resistant alloy CR EN 12165 CW602N high resistance polymer stainless steel and high resistance polymer stainless steel EPDM - - - - dezincification resistant alloy CR EN 12165 CW602N
Performance Medium: Maximum percentage of glycol: Maximum working pressure: Working temperature range: Δp Range: Flow rates: Accuracy:	water, glycol solutions 50% 25 bar -20-100°C 15-200 kPa 0,085-11,0 m³/h ±10%	water, glycol solutions 50% 25 bar -20-100°C 15-200 kPa 0,085-11,0 m³/h ±10%
Connections	1/2"-2" F with union x F	1/2"-2" F
Pressure ports connections	1/4" F	1/4" F

Dimensions

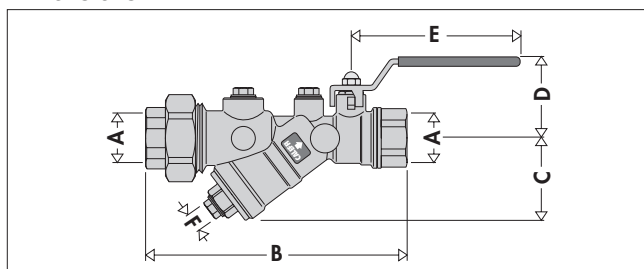

Code	A	B	C	D	E	F	Mass (kg)
121141 ...	1/2"	156,5	52,5	50	100	1/4"	1,00
121151 ...	3/4"	159,5	52,5	50	100	1/4"	1,00
121161 ...	1"	218,5	68	66	120	1/2"	1,85
121171 ...	1 1/4"	220,5	68	66	120	1/2"	1,87
121181 ...	1 1/2"	253	84	88	140	1/2"	4,60
121191 ...	2"	253	84	88	140	1/2"	4,60

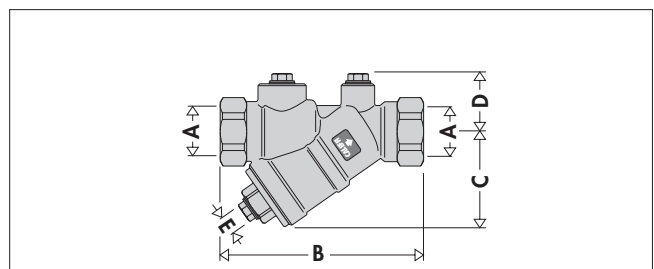

Code	A	B	C	D	E	Mass (kg)
126141 ...	1/2"	101	52,5	30	1/4"	0,45
126151 ...	3/4"	106	52,5	30	1/4"	0,48
126161 ...	1"	140,5	102	33,5	1/2"	1,36
126171 ...	1 1/4"	148	102	33,5	1/2"	1,24
126181 ...	1 1/2"	177	105	38,5	1/2"	2,25
126191 ...	2"	179	105	38,5	1/2"	2,45

Circuit balancing

Modern heating and air-conditioning systems have to guarantee a high level of thermal comfort with a low consumption of energy. This means supplying the system terminal emitters with the correct design flow rates, to produce balanced hydraulic circuits.

Unbalanced circuits

If a circuit is not balanced, the hydraulic imbalance between emitters creates areas with temperatures which are not uniform, problems with thermal comfort, and higher energy consumption.

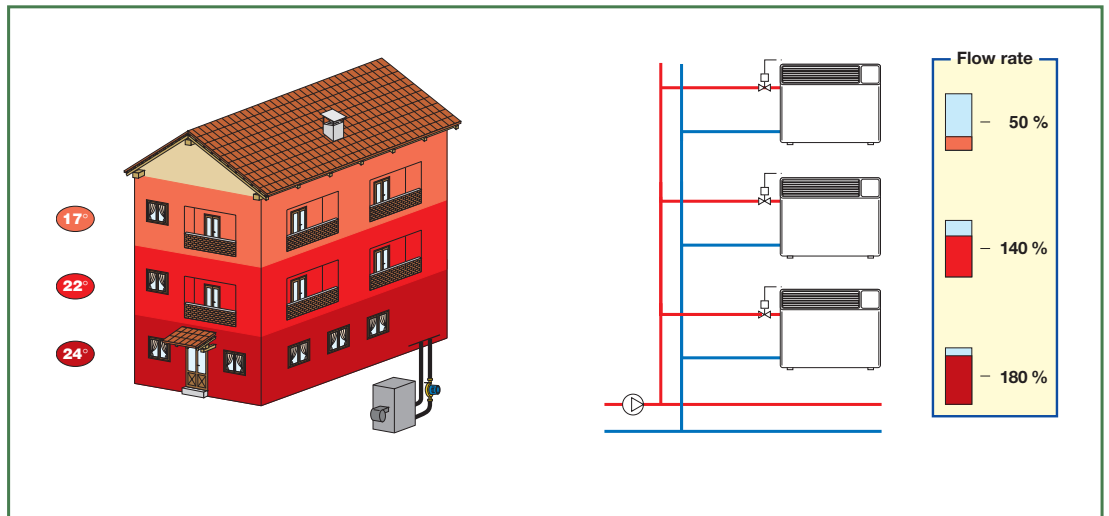

Circuits balanced with manual valves

Traditionally, hydraulic circuits are balanced using manual calibration valves. With these static-type devices, such circuits are difficult to balance perfectly and have operating limitations in the case of partial closure by means of the regulating valves. The flow rate in the open circuits **does not remain constant at the nominal value.**

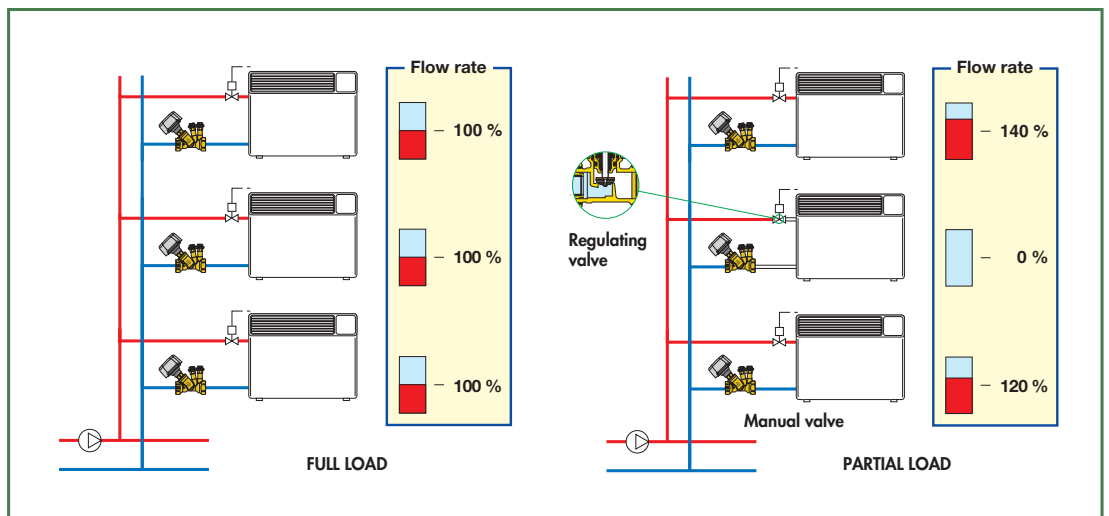

Circuits balanced with AUTOFLOW®

AUTOFLOW® balances the hydraulic circuit automatically, ensuring that each terminal emitter receives the design flow rate. Even in the case of partial circuit closure by means of the regulating valves, the flow rates in the open circuits **remain constant at the nominal value.** The system always guarantees the greatest comfort and the highest energy savings.

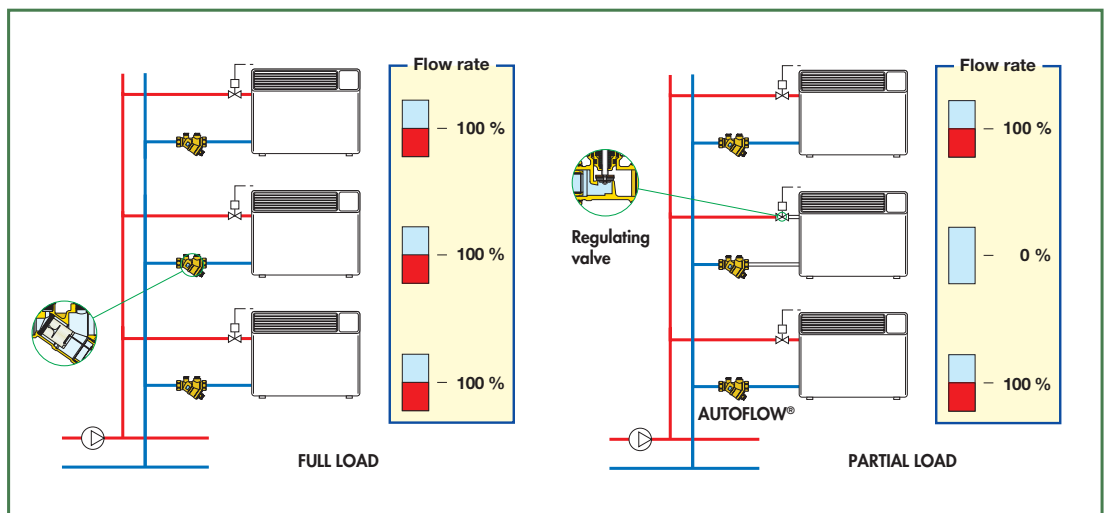

AUTOFLOW® devices

Function

The AUTOFLOW® device has to guarantee a constant flow rate when its upstream/downstream pressure differential varies.

It is therefore necessary to refer to the Δp - flow rate diagram and a basic diagram illustrating the methods of operation and the effects of the relevant variables.

Operating principle

The regulating element of these devices is a piston and a cylinder that has side apertures, with fixed and variable geometry, through which the medium flows. These apertures are governed by the movement of the piston on which the thrust of the medium acts. A specially calibrated spring counteracts this movement.

AUTOFLOW® are high performance automatic regulators. They regulate the flow rates selected within a very tight tolerance (approx. 10%) and offer a wide range of operation.

Below the control range

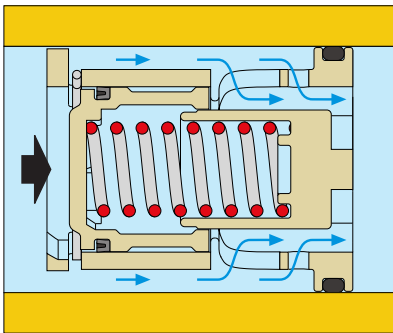

In this case, the regulating piston remains in equilibrium without compressing the spring and gives the medium the maximum free flow area. In practice, the piston acts as a fixed regulator and thus the flow through the AUTOFLOW® depends solely on the differential pressure.

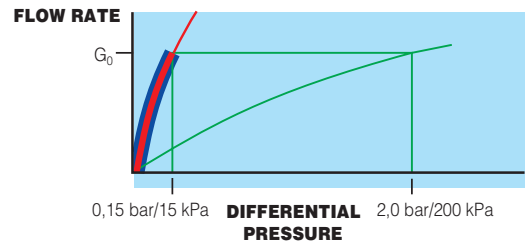
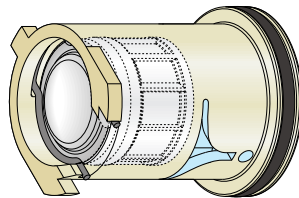

$$Kv_{0,01} = 0,258 \cdot G_0 \quad \text{Range } \Delta p \text{ 15+200 kPa} \quad \text{where } G_0 = \text{nominal flow rate}$$

Within the control range

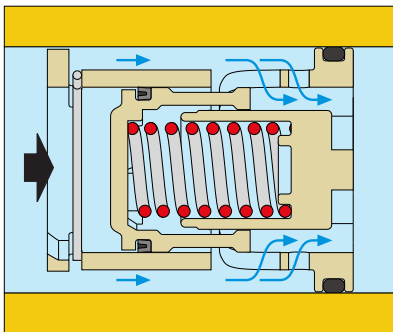

If the differential pressure is contained within the control range, the piston compresses the spring and gives the medium a free flow area to permit regular flow at the nominal rate for which the AUTOFLOW® is set up.

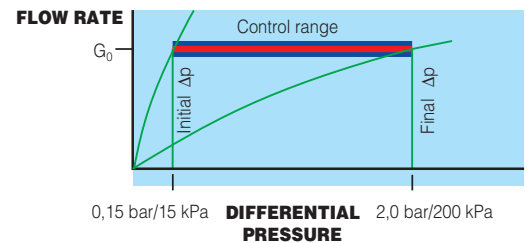
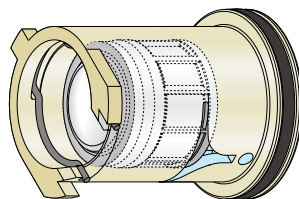

Above the control range

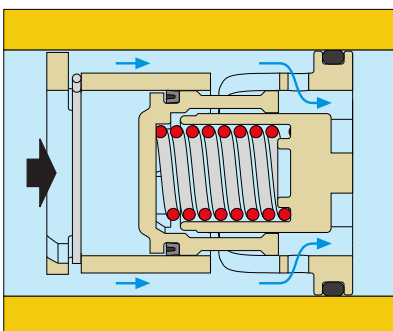

In this case, the piston compresses the spring fully and only leaves the fixed geometry aperture for the medium to pass through.

As in the first case above, the piston acts as a fixed regulator. The flow rate through the AUTOFLOW® thus depends solely on the differential pressure.

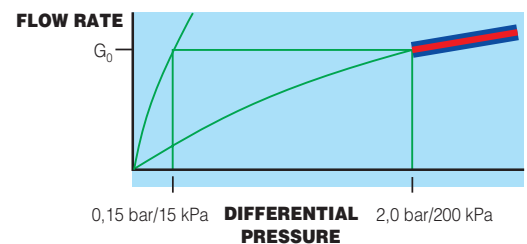
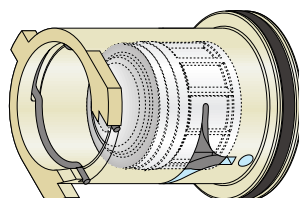

$$Kv_{0,01} = 0,070 \cdot G_0 \quad \text{Range } \Delta p \text{ 15+200 kPa} \quad \text{where } G_0 = \text{nominal flow rate}$$

Construction details

Polymer regulator

The flow-rate regulator element is made entirely of high-resistance polymer, specially chosen for use in air-conditioning and plumbing systems.

Its mechanical behaviour is excellent in a wide range of working temperatures, it features high resistance to abrasion due to the medium flowing continuously, it is insensitive to the deposit of scale and is fully compatible with the glycols and additives used in circuits.

Exclusive design

The regulator, thanks to its exclusive design, is able to accurately regulate the flow rate in a wide range of operating pressures. A special internal chamber acts as a damper for the beating and vibration triggered by the flow of the medium, making sure the device works quietly.

For these reasons it can be used in system circuits on both zone outlets and directly at the terminal emitters.

Ball valve

The control stem of the ball valve has a blowout-proof stem and the reversible closing lever is covered with vinyl. If there are any insulated pipes, it can be changed with the extended lever series 117.

Replaceable cartridge

The internal regulator is assembled in the form of a self contained cartridge so as to permit easy removal from the body for inspection or replacement. It is equipped with a special automatic fixing system with wire and an operating ring for fast and safe positioning without using tools.

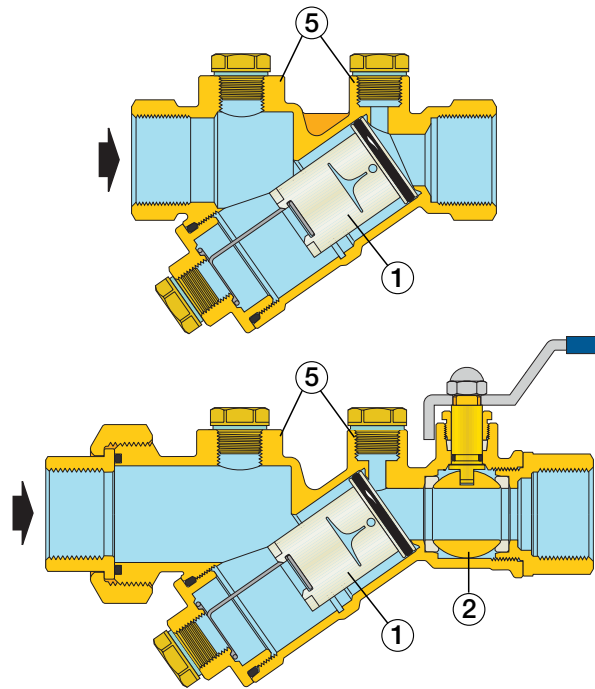
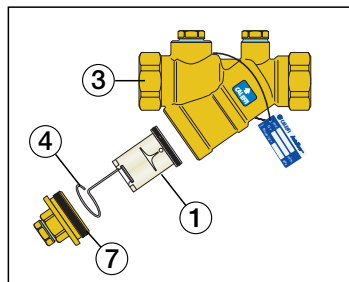

Connecting the device

The body of the AUTOFLOW® device is fitted with connections for the pressure ports, which is useful when checking operation in the working range. In addition, the cartridge plug contains a connection to be able to use a circuit drain valve.

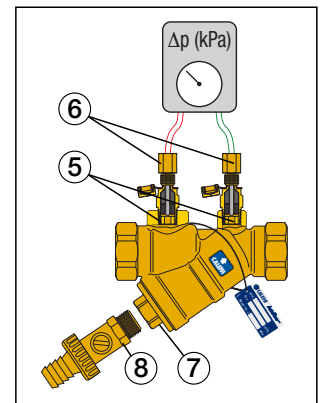

Sizing the circuit with AUTOFLOW®

Sizing the circuit containing AUTOFLOW® is particularly easy to accomplish. As illustrated by the diagrams, shown alongside by way of example, the calculation of the head loss for choosing the pump is made by referring to the hydraulically most unfavourable circuit and adding this value to the minimum differential pressure required by the Autoflow. In the example the circuits have the same nominal flow rate.

The AUTOFLOW® devices, located on intermediate circuits, automatically absorb the excess differential pressure to ensure the corresponding nominal flow rate.

As the regulating valves open or close, the AUTOFLOW® repositions itself dynamically to maintain the nominal flow rate (50% load = circuits 3, 5, 7, 8 closed).

For more detailed information on sizing a system with AUTOFLOW®, please refer to the 2nd volume of the Caleffi Handbooks and the technical report "Dynamic balancing of hydronic circuits". They give theoretical calculations, numerical examples and notes on the application of the above-mentioned devices in circuits.

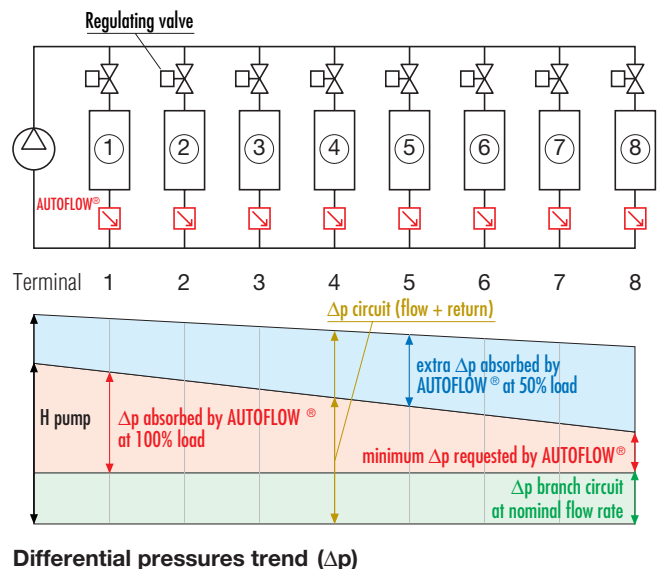

Applications of AUTOFLOW® ()

Installation of AUTOFLOW®

In air-conditioning systems, AUTOFLOW® devices must preferably be installed on the circuit return pipe. Some typical installation examples are given below.

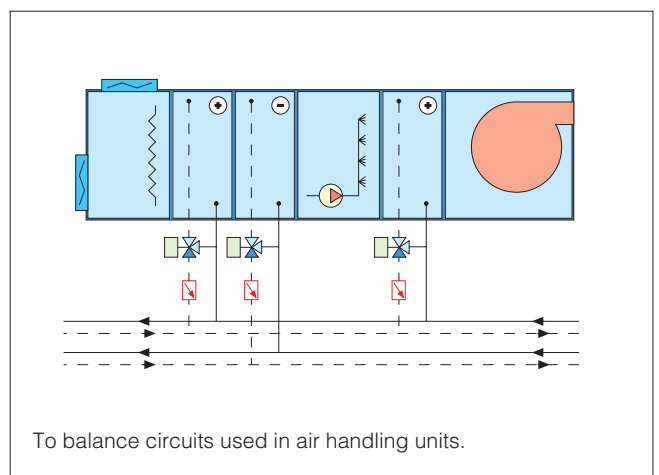
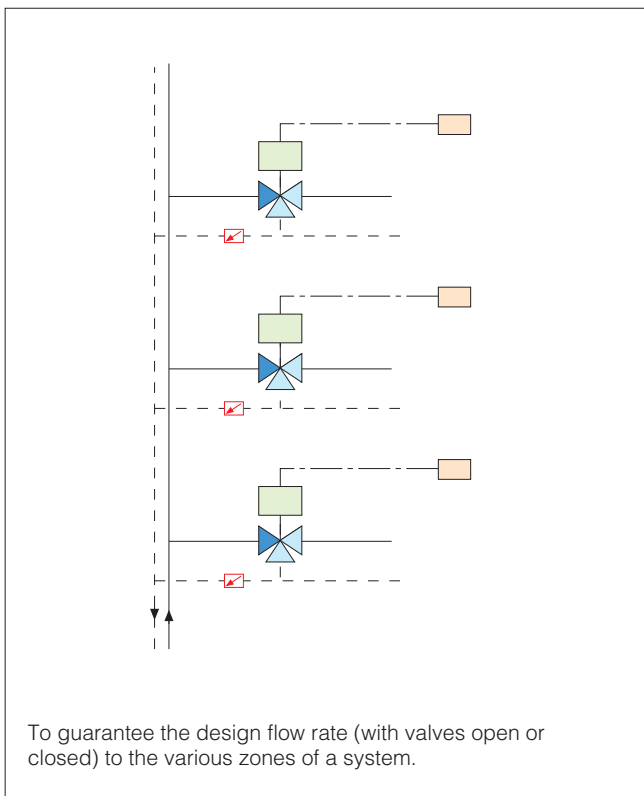
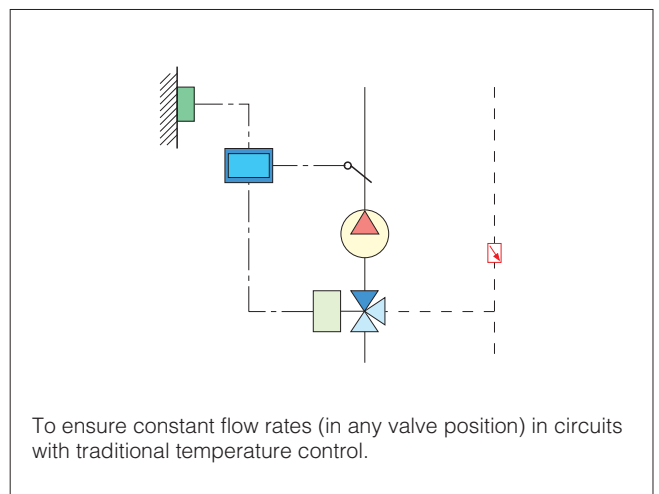
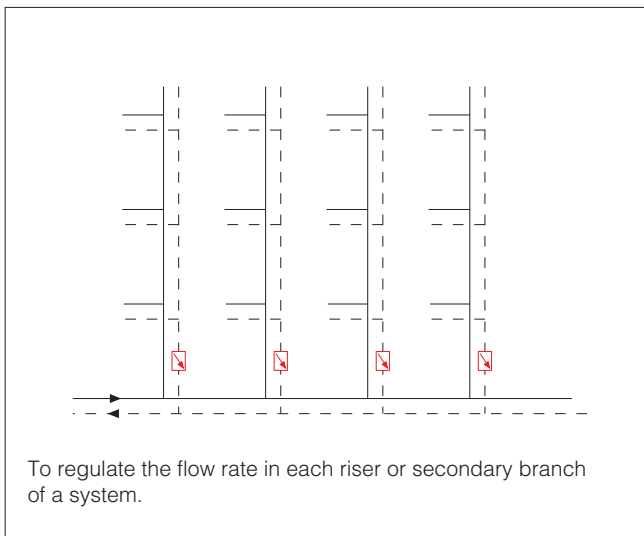
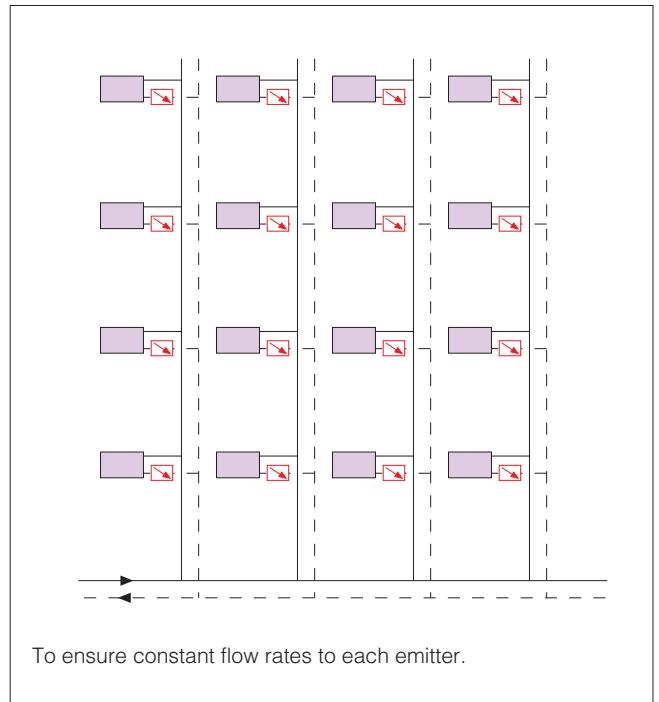
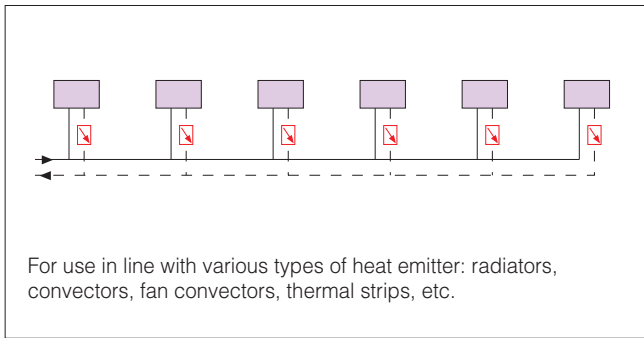

Applications of AUTOFLOW®

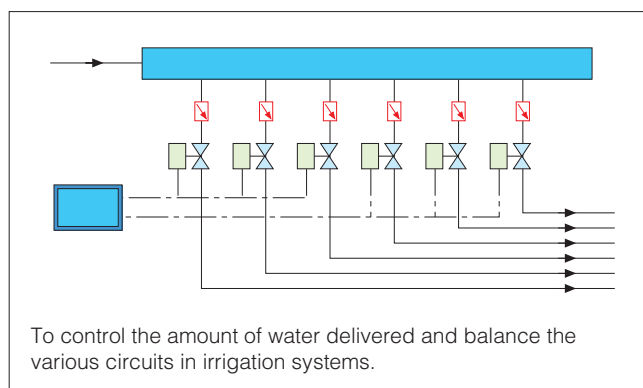
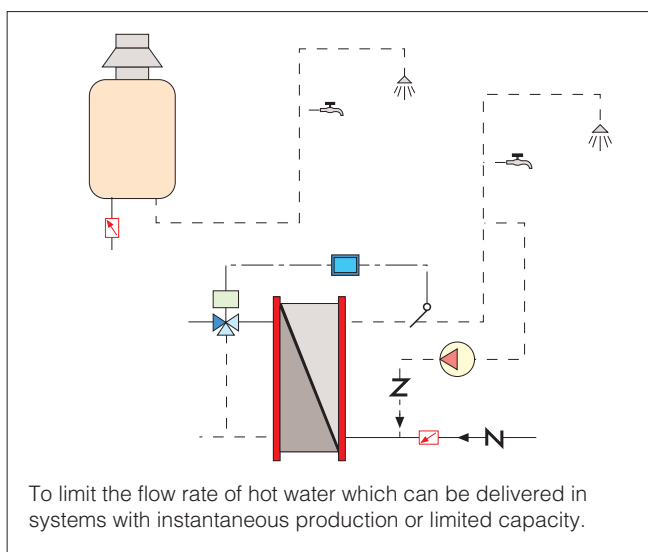
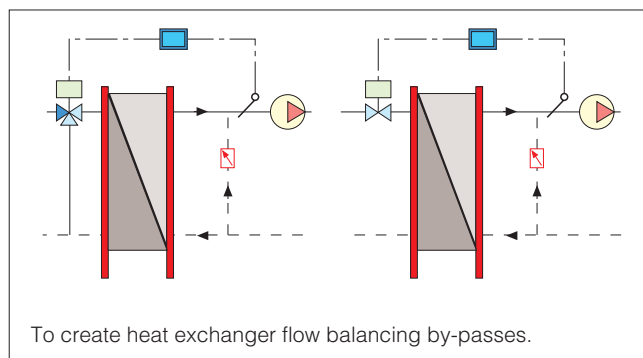
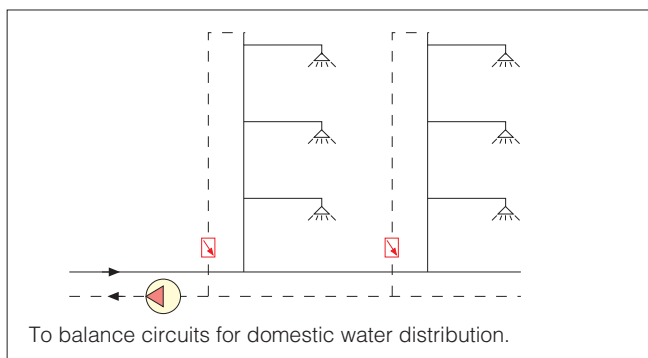

For further details, consult Applications Sheets Nos. 04301, 04302, 04303 and the technical report "Dynamic Balancing of Hydronic Systems".

Accessories

120 STRAINER Version

Combination of filter and ball valve.



QR dezincification resistant alloy body.
Stainless steel strainer cartridge.
Maximum working pressure:
Temperature range:
Strainer mesh size Ø:

25 bar
0–110°C
1/2"–1 1/4": 0,87 mm
1 1/2" and 2": 0,73 mm

Fitted for connecting pressure ports and drain valve.

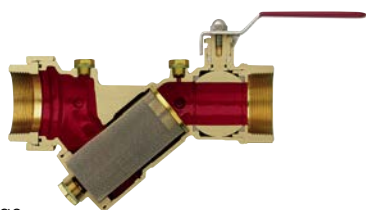

Code		Kv _{0,01} (l/h)
120141 000	1/2"	687
120151 000	3/4"	725
120161 000	1"	1.665
120171 000	1 1/4"	1.723
120181 000	1 1/2"	3.913
120191 000	2"	3.969

Head losses

- The stated values of kv_{0,01} refer to the body of the device with strainer.

125 STRAINER Version

Y-filter.



QR dezincification resistant alloy body.
Stainless steel strainer cartridge.
Maximum working pressure:
Temperature range:
Strainer mesh size Ø:

25 bar
-20–110°C
1/2"–1 1/4": 0,87 mm
1 1/2" and 2": 0,73 mm

Fitted for connecting pressure ports and drain valve.

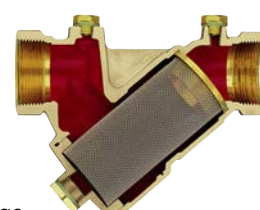

Code		Kv _{0,01} (l/h)
125141 000	1/2"	688
125151 000	3/4"	705
125161 000	1"	1.410
125171 000	1 1/4"	1.494
125181 000	1 1/2"	3.227
125191 000	2"	3.621

Head losses

- The stated values of kv_{0,01} refer to the body of the device with strainer.

130

Electronic flow rate and differential pressure measuring station. Supplied complete with shut-off and connection fittings. Can be used for measuring the flow rate of balancing valves 130 series and of the flow metering device 683 series. Suitable for Δp measurement of automatic flow rate regulators. Electric supply from battery. Bluetooth® transmission between Δp measuring station and remote control unit. Versions complete with remote control unit Windows Mobile® or with Android® application for Smartphone and Tablet.

Measurement range: 0–1000 kPa.
Static Pmax: 1000 kPa.



Code

130006	with remote control unit, with Android® application
130005	without remote control unit, with Android® application



538

Drain cock with hose connection.
Max. working pressure: 10 bar.
Max. working temperature: 110°C.

Code

538201	1/4"
538400	1/2" with cap

100



Pair of fast-plug pressure/temperature test ports. Their special construction allows rapid and accurate measurements while ensuring leaktightness. Can be used for:

- checking the working range of AUTOFLOW®;
- checking the clog degree of strainers;
- checking the heat output of the terminals.

Cap cover facing available in:

- - Red for upstream pressure test port.
- - Green for downstream pressure test port.

Brass body.
EPDM seals.
Max. working pressure: 30 bar.
Temperature range: -5–130°C.

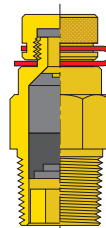

Code

100000	1/4"
--------	------

100



Pair of fittings with fast-plug syringe for connection of pressure ports to measuring instruments. 1/4" female threaded connection. Max. working pressure: 10 bar. Max. working temperature: 110°C

Code

100010	1/4"
--------	------

SPECIFICATION SUMMARIES

121 series

Automatic flow rate regulator and ball valve, AUTOFLOW®. Connections 1/2" (3/4", 1", 1 1/4", 1 1/2" and 2") F with union x F. Dezincification resistant alloy body. High resistance polymer cartridge (1 1/2" and 2" high-resistance polymer cartridge and stainless steel). Stainless steel spring. EPDM seals. Chrome plated brass ball. PTFE ball seat and stem seal. Galvanized steel lever. Dezincification resistant alloy pressure port plugs. Medium water and glycol solutions. Maximum percentage of glycol 50%. Maximum working pressure 25 bar. Temperature range -20–100°C. Accuracy $\pm 10\%$. Δp range 15–200 kPa. Range of available flow rates 0,085–11,0 m³/h.

126 series

Automatic flow rate regulator, AUTOFLOW®. Connections 1/2" (3/4", 1", 1 1/4", 1 1/2" and 2") F x F. Dezincification resistant alloy body. High resistance polymer cartridge (1 1/2" and 2" high resistance polymer cartridge and stainless steel). Stainless steel spring. EPDM seals. Dezincification resistant alloy pressure port plugs. Medium water and glycol solutions. Maximum percentage of glycol 50%. Maximum working pressure 25 bar. Temperature range -20–100°C. Accuracy $\pm 10\%$. Range Δp 15–200 kPa. Range of available flow rates 0,085–11,0 m³/h.

We reserve the right to make changes and improvements to the products and related data in this publication, at any time and without prior notice.