

FLOWING EXPERTISE

CIRCUIT BALANCING DEVICES



THE CALEFFI GREEN



THIS IS OUR SUSTAINABLE COMMITMENT.
A BELIEF, A WAY OF LIFE AND A WAY OF DOING THINGS.
THIS IS OUR TANGIBLE CONTRIBUTION
TO ENVIRONMENTAL AND SOCIAL CHANGE.

We are building a more responsible future to meet the demands made by the **PEOPLE** of today and tomorrow, through **PRODUCTS** that will help them to save resources and that are designed to offer a more sustainable kind of comfort. To bring the perfect climate to life and have a positive impact on the **ENVIRONMENT.**



GREEN **R**EVOLUTION

SMART DESIGN



CIRCUIT BALANCING COMPONENTS

These contribute to the transition to a green economy, ensuring the outstanding energy performance of buildings.

OPTIMUM EFFICIENCY and **BENEFITS** for the user and the environment through proper application within the building design.



CIRCUIT BALANCING DEVICES

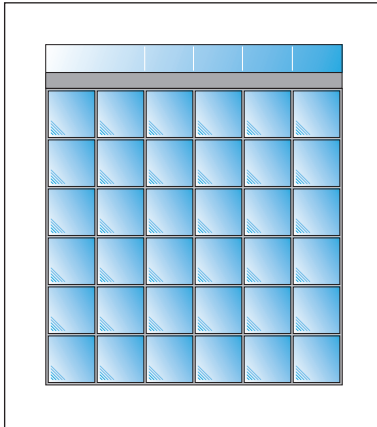

The hydronic circuits serving heating and cooling systems must be balanced, meaning that they must be constructed in such a way as to guarantee the design flow rates of the thermal medium. Depending on the type of system and the appliances installed, and also on the type of control to be implemented, specific balancing devices are required. Caleffi offers a complete line of products, as illustrated in this guide.

Air conditioning of modern buildings

Modern buildings must be designed and built to ensure the health and general wellness of their occupants, assisting the maintenance of various types of comfort: thermal, acoustic, architectural, functional, and so forth.

In addition, the buildings must be constructed with the aim of achieving fundamental goals including energy saving and environmental protection, with reduced CO2 emissions.

Controlling the climate of a confined space means creating the necessary conditions to guarantee the **thermal comfort** of its occupants.

Thermal comfort

Thermal comfort is the sensation of thermohygrometric well-being that a person experiences when conducting an activity in an enclosed space. In these comfort conditions the physiological mechanisms of the human body act correctly to control body temperature by exchanging thermal energy and water vapour with the surrounding environment. The ideal reference situation is designated "thermal neutrality", wherein the person does not perceive sensations of heat or cold.

Air conditioning makes it possible to control the **temperature, relative humidity and air velocity** in living spaces irrespective of the outside climatic conditions or season. The ASHRAE, REHVA, and ISO organisations have issued specific standards for the achievement of thermal comfort, forming a body of references for the law applied to air conditioning issues both on the national and international levels.

Average reference conditions for thermal comfort

	Winter	Summer
Ambient temperature (°C)	≥ 20	≤ 26
Minimum relative humidity (%)	35	50
Maximum relative humidity (%)	45	60

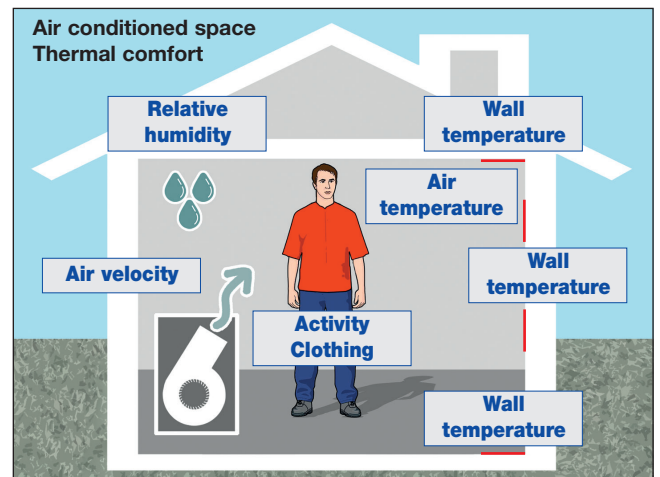
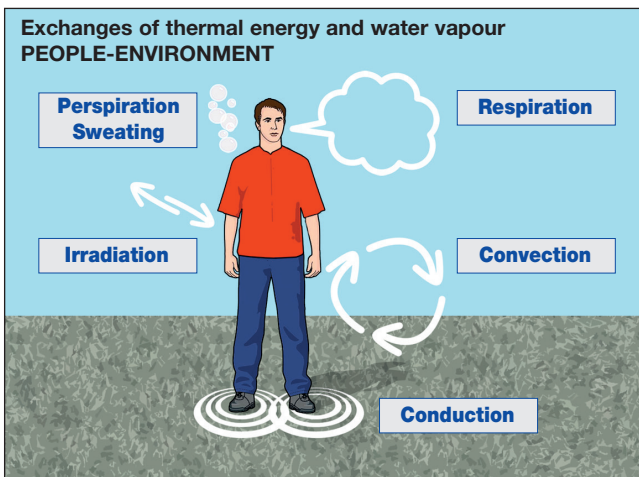

Thermal exchange terminals

The thermal exchange terminals, used for air conditioning, employ a **thermal medium flow rate to control the thermal energy** required to manage room temperature and humidity.

The formula $P = \text{const} \times G \times \Delta T$ establishes that **the emission or subtraction of heat (P) by the terminals is a function of the flow rate of the medium (G) passing through them**, given the temperature difference (ΔT) of the thermal medium in the terminal. The design flow rate at the terminal is also a necessary condition for the removal of air humidity condensing latent heat during dehumidification operation.

On the basis of these physical laws it can be asserted that **flow rate balancing and regulation** are directly connected with the achievement and maintenance of thermal comfort conditions.

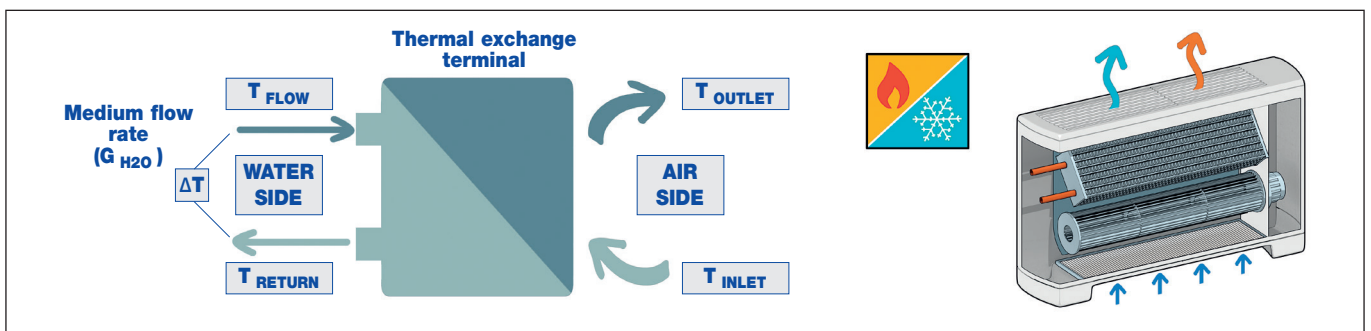

Fan coils

Fan coils are terminals that heat or cool the room due to forced convection. They can be floor-standing or ceiling mounted, with either exposed or recessed installation.

They are composed of:

- box
- single or double finned heat exchange coil
- centrifugal or tangential fan
- air inlet filter
- condensation drip tray

The units function with hot or chilled medium in heating or air conditioning mode. They control room relative humidity, either totally or partially.

Hot thermal medium working T range: 45–65 °C

Chilled thermal medium working T range: 7–12 °C

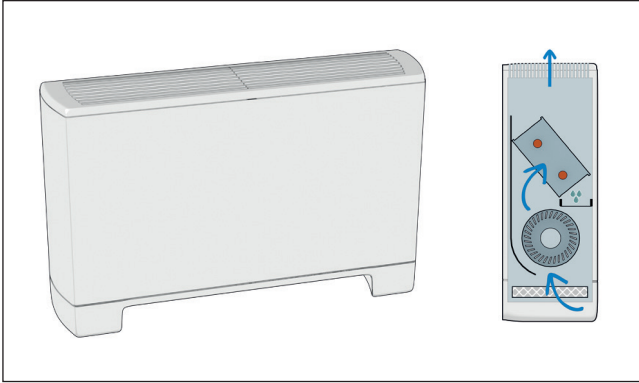

Radiant panels

Radiant panels are terminals that heat or cool the room due to irradiation. They are composed of plastic pipes embedded in the masonry structure of walls and floors.

The units function with hot or chilled thermal media in heating or cooling mode. Radiant panels do not control relative ambient humidity.

Hot thermal medium working T range: 22–45 °C

Chilled thermal medium working T range: 16–20 °C

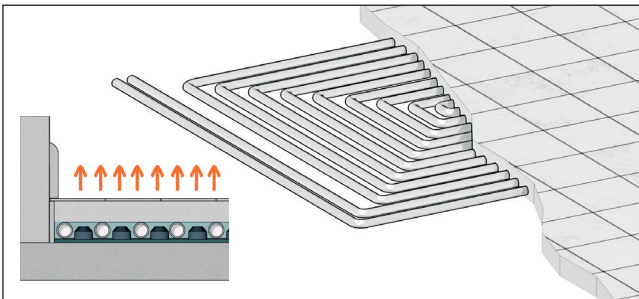

Radiators

Radiators are heating terminals that heat the room air due to natural convection and irradiation. Radiators are constructed in metal and are of the elements, plate or pipes type.

They function exclusively with hot thermal medium in heating mode.

Hot thermal medium working T range: 55–90 °C

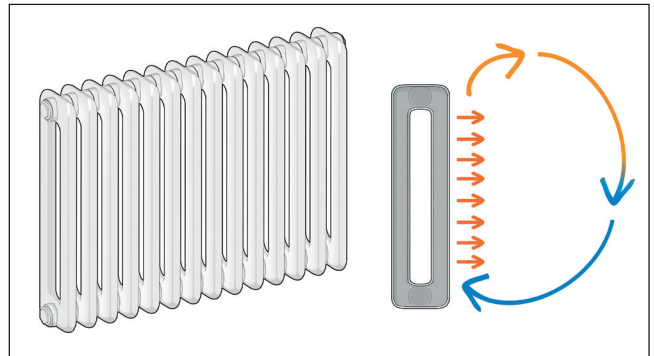

Cooling beams

Cooling beams are terminals that heat or cool the room by the combined action of primary air and inlet air from the room. The beams are installed on the ceiling in either exposed or recessed configuration.

They are composed of:

- a pressurised primary air supply pipe
- single or double finned heat exchange coil
- vents to supply treated air to the room
- air enclosure and ducting structure

The units function with hot or chilled thermal media in heating or cooling mode. Cooling beams do not directly control relative ambient humidity, which is instead managed by the primary air.

Hot thermal medium working T range: 30–45 °C

Chilled thermal medium working T range: 14–18 °C

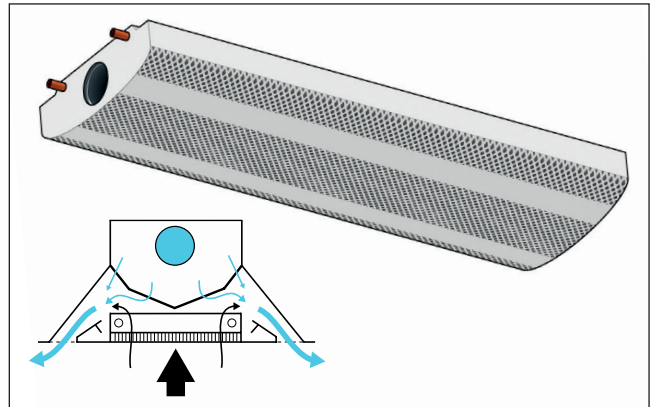

Air Handling Units (AHU)

These are modular units configured in such a way as to provide correct treatment of primary air before transferring it to the air conditioned space.

The air is controlled thermally, in terms of temperature and relative humidity, and also in terms of air quality, by means of appropriate filtration.

They are composed of:

- filter section
- heating section with finned heating coil
- cooling and dehumidification section with finned cooling coil and condensation drip tray
- humidification section, which can be of the water or vapour type
- post-heating section with finned heating coil
- flow and inlet section with fans
- section for heat recovery between inlet and outlet air

The units function with hot or chilled medium in heating or air conditioning mode. Air handlers also control relative ambient humidity.

Hot thermal medium working T range: 40–60 °C

Chilled thermal medium working T range: 7–12 °C

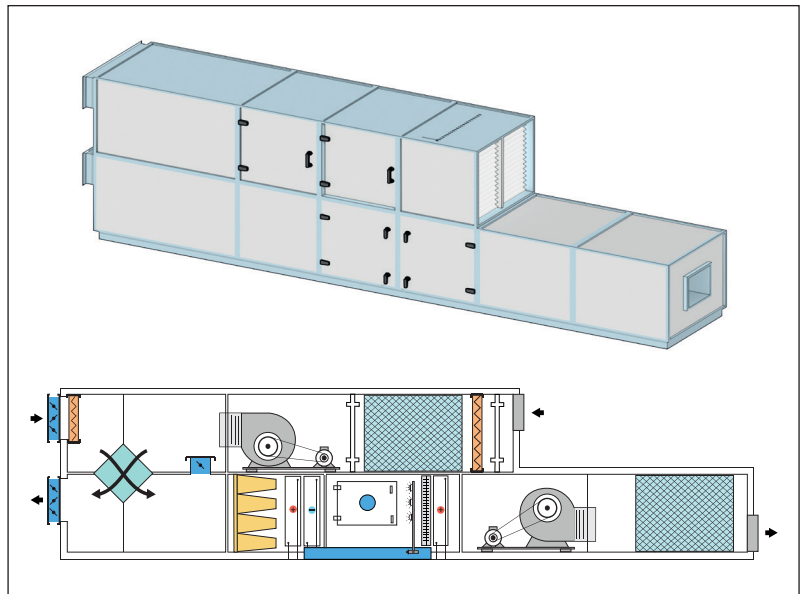

Energy certification of buildings

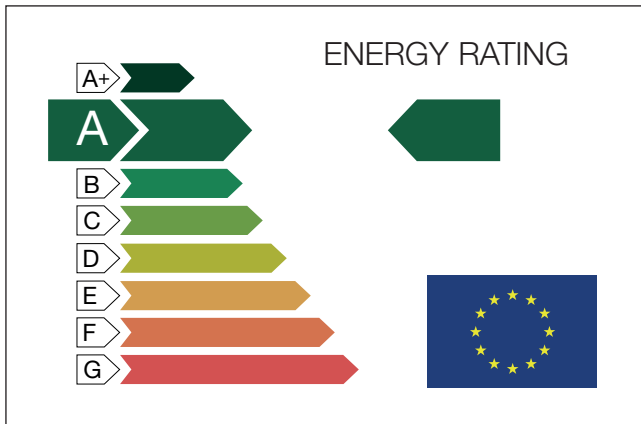

Several years ago national and international laws and regulations were put in place to ensure the energy classification of buildings. In this context, buildings are designed in such a way as to restrict thermal energy and electricity requirements and to minimise carbon dioxide emissions (CO₂).

Apart from defining the thermal insulation characteristics of the building, also the construction and operation of the heating and cooling system are of critical importance and must be adequate to follow the thermal loads trend precisely during the summer and winter.

The entire system, from the production zone to the area of emission or subtraction of thermal energy in the air conditioned space, must be correctly sized with a suitable choice of regulating components and must be commissioned using clearly defined instruments and procedures (test, adjustment and balancing).

Hydronic circuit - Flow rate control

Flow rate control devices can be classified in relation to the function performed in the specific points of the distribution network in which they are installed.

- **Flow rate balancing point:** guarantee the nominal design flow rate
- **Flow rate regulating point:** continuously adapt the flow rate in response to changes in the thermal load

In guaranteeing the correct flow rate to the thermal exchange terminal, it is possible to manage the two forms of thermal energy supplied to or removed from the space:

- sensible heat: linked to temperature variation
- latent heat: linked to relative humidity variation

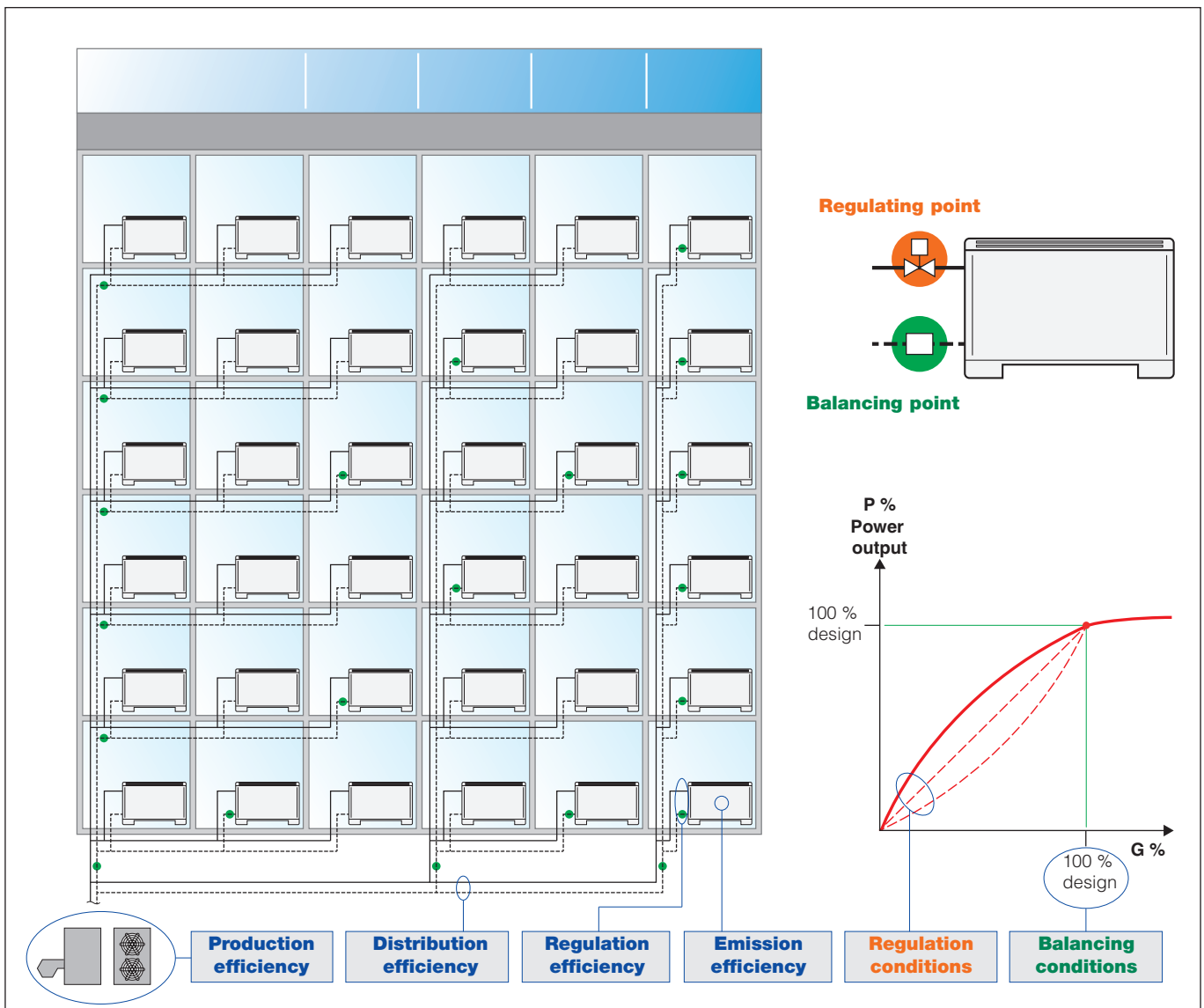

Circuit balancing devices

Circuit balancing devices **can be classified in accordance with their method of action and the type of control** they perform in relation to the hydraulic circuit. In this guide the devices are **presented in accordance with a functional product evolution line**, as shown in the following summary table. The same description appears at the start of each of the product sections.

Moreover, the functional details **associated with specific system design aspects are described through pages inserted** in the various sections of the guide, in a rational presentation designed to aid the identification of products and allow them to be selected in the optimal manner.

Static balancing devices

- Manual balancing valve, with fixed orifice	130 series		
- Manual balancing valve, with variable orifice 130 series			
- Balancing valve with flow meter	132 series		

Dynamic balancing devices

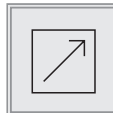
- Automatic flow rate regulator, fixed flow rate	127 - 128 - 121 126 - 120 - 125 103 series		
--	--	---	---

Dynamic balancing and regulating devices

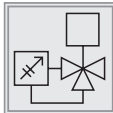
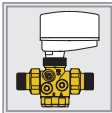
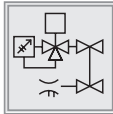
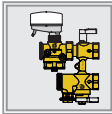
- Pressure independent control valve (PICV)	145 - 146 series		
- Connection and regulation kit for HVAC terminal units	149 series		

Differential pressure regulating devices

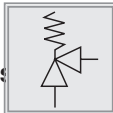
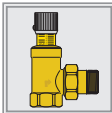
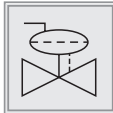
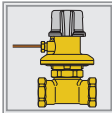
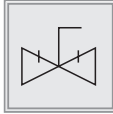
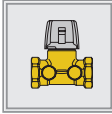
- Differential by-pass valve	518 series - 519 series		
- Differential pressure regulator 140 series			
- Shut-off and preset valve 142 series			

Devices for balancing radiator and radiant panel circuit

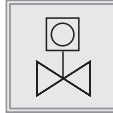
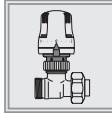
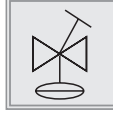
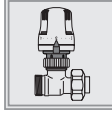
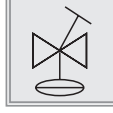
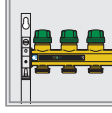
- Convertible radiator valves with pre-setting	425 - 426 421 - 422 series		
- Dynamic thermostatic valves	230 series		
- Dynamic manifold for radiant panel systems	665 series		

Dynamic thermostatic balancing devices

- Thermostatic regulator for domestic hot water recirculation circuits	116 series		
--	------------	---	---

Static balancing devices

- Manual balancing valve, with fixed orifice

130 series

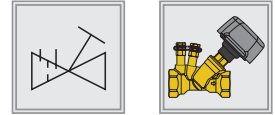

- Manual balancing valve, with variable orifice 130 series

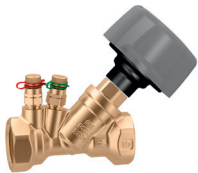
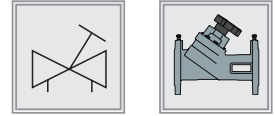

130

tech. broch. 01251

Hydraulic circuits balancing valve **with fixed orifice**.
Flow meter with Venturi device.
Dezincification resistant alloy body **CR**,
stainless steel obturator.
Complete with quick-fit pressure test ports.
Max. working pressure: 16 bar.
Working temperature range: -20–120 °C.
Max. percentage of glycol: 50 %



Code	DN	1/2"	3/4"	1"	1 1/4"	1 1/2"	2"
130400	DN 15	1/2"					
130500	DN 20	3/4"					
130600	DN 25	1"					
130700	DN 32	1 1/4"					
130800	DN 40	1 1/2"					
130900	DN 50	2"					



130

tech. broch. 01251

Hydraulic circuits balancing valve **with variable orifice**.
Body: - DN 65–200: grey cast iron
- DN 250300: ductile cast iron.
Obturator: - DN 65–200: technopolymer
- DN 250300: ductile cast iron.
Complete with quick-fit pressure test ports.
Max. working pressure: 16 bar.
Working temperature range:
DN 65–DN 300: -10–120 °C.
Max. percentage of glycol: 50 %
Flanged PN 16 connections.
To be coupled with counterflanges
EN 1092-1.

Code	DN	Kvs (m³/h)
130063	DN 65	71.8
130083	DN 80	108
130103	DN 100	181
130123	DN 125	255.2
130153	DN 150	370,5
130203	DN 200	927,1
130253	DN 250	1102,5
130303	DN 300	1516

Technical specifications

series ↗	130 threaded	130 flanged
Performance		
Medium:	water, non-hazardous glycol solutions excluded from the guidelines of directive 67/548/EC	water, non-hazardous glycol solutions excluded from the guidelines of directive 67/548/EC
Max. percentage of glycol:	50 %	50 %
Maximum working pressure:	16 bar	16 bar
Working temperature range:	-20–120 °C	-10–120 °C
Accuracy:	± 10 %	± 10 %

Operating principle

The balancing valve is a hydraulic device that regulates the flow rate of the medium passing through it.

Regulation is performed using a knob that governs the movement of an obturator, to regulate the flow of the medium. The flow rate is controlled according to the Δp value, which is measured with two piezometric connections suitably positioned on the valve.

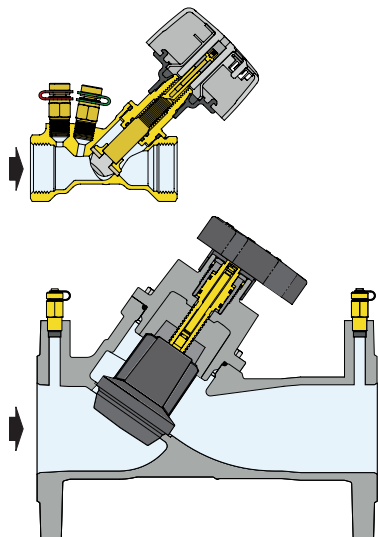

Venturi device for flow rate measurement

The 130 series valves of size from 1/2" to 2" are equipped with a flow rate measuring device based on the Venturi principle. It is housed in the valve body and is located upstream of the valve obturator, as shown in the figure.

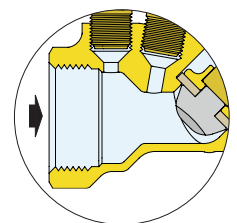

This system provides the following benefits:

1. Provides stable measurement during flow rate regulation. Balancing valves normally have their pressure test ports upstream and downstream of the valve obturator. This means that when the valve is closed to less than 50 % of its full opening, the turbulence created downstream of the obturator causes instability in the pressure signal, causing significant measurement errors.
2. The Venturi system makes for a faster process of measurement and manual circuit balancing. The flow rate is now only a function of the Δp measured upstream and downstream from the fixed orifice of the Venturi meter, upstream from the obturator, and no longer through the entire valve.

Static balancing devices

Adjustment knob

The shape of the adjustment knob is the outcome of research into ergonomics to ensure the greatest operator comfort and accurate adjustment.

- The adjustment range with 5 complete turns permits great accuracy when balancing hydraulic circuits.
- The micrometric scale large and clear, making the flow rate adjustment.
- The knob is made of high-resistance corrosion-proof, reinforced polymere



130

tech. broch. 01251

Electronic flow rate and differential pressure meter.
For more details, see page 22- 23.



Code

- | | |
|---------------|--|
| 130006 | complete with remote control unit, with Android® application |
| 130005 | without remote control unit, with Android® application |



Setting the balancing valve

Flow rate regulation in balancing valves **with variable orifice requires a suitable differential pressure measuring instrument.**

In this valve type each position of the setting knob is associated with a specific characteristic curve. This requires a fresh data entry each time the position is changed. It is thus essential to use **a specific electronic instrument** and follow a stringent setting procedure.

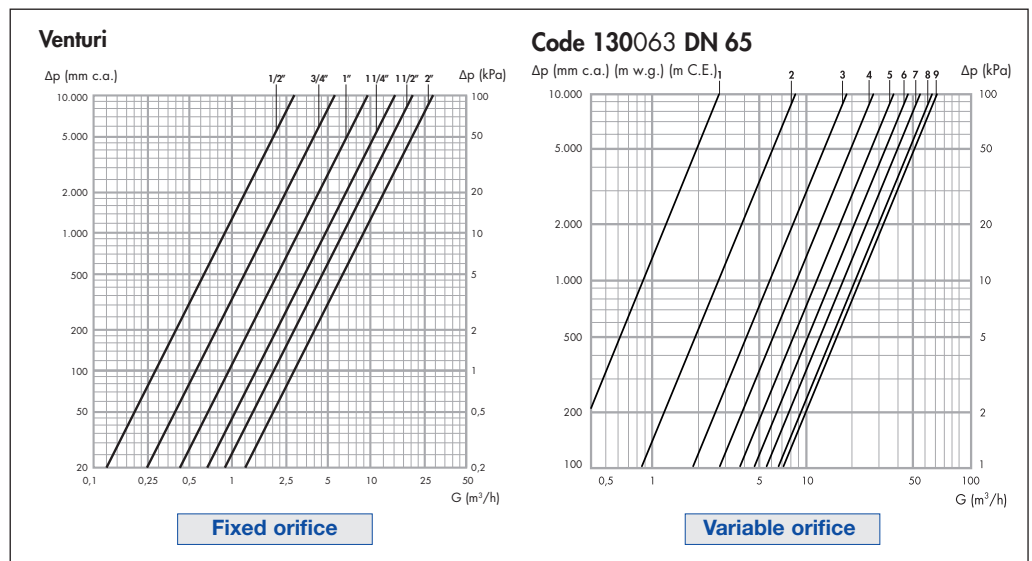

Main applications - Manual balancing valves

- ✓ constant flow rate circuits with three-way regulating valves
- ✓ chillers or heat generators connected in parallel with dedicated pumps
- ✓ fire fighting water distribution circuits, with hydrants
- ✓ flow rate and head control on pump flow line
- ✓ regulating circuits with flow temperature control, with primary-secondary coupling

To balance zone branches in circuits with three-way valve

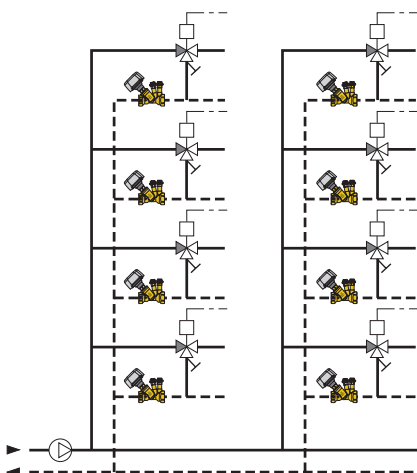

To balance by-pass and direct lines in circuits with three-way valve

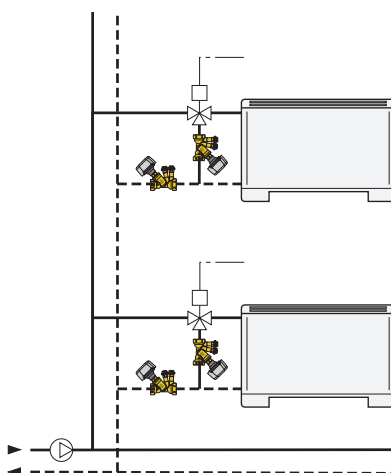

To balance the circuits that serve chiller unit evaporators or condensers

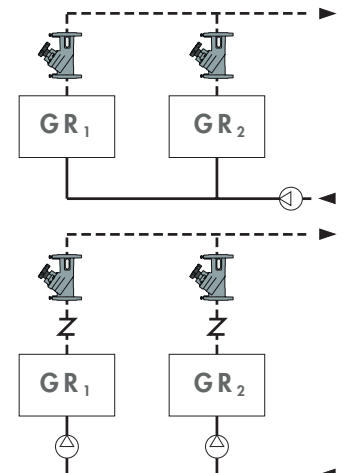

Static balancing devices

- Balancing valve with flow meter

132 series

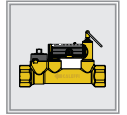
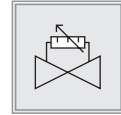

132

tech. broch. 01149

Balancing valve with flow meter.
Direct reading of flow rate.
Brass valve body and flow meter.
Ball valve for flow rate adjustment.
Graduated scale flow meter with magnetic movement flow rate indicator.

With insulation. PATENT.

Technical specifications

Performance

Medium: water, glycol solutions
Max. percentage of glycol:
Maximum working pressure:
Working temperature range:

50 %
10 bar
-10–110 °C

Flow rate scale unit of measurement:
Accuracy:

l/min
± 10 %

Operating principle

The balancing valve is a hydraulic device that regulates the flow rate of the medium passing through it.

The regulating action is performed by a ball obturator (1), operated by a control stem (2). The flow rate is controlled by means of a flow meter (3) housed in a by-pass circuit, on the valve body, that can be shut off

during normal operation. The flow rate value is indicated by a metal ball (4), sliding within a transparent guide (5), marked at the side with a graduated scale (6).

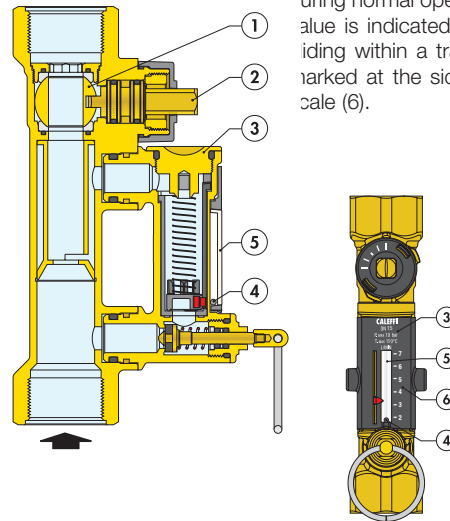

Code		Flow rate range (l/min)
132402	DN 15	2– 7
132512	DN 20	5– 13
132522	DN 20	7– 28
132602	DN 25	10– 40
132702	DN 32	20– 70
132802	DN 40	30–120
132902	DN 50	50–200



132

Balancing valve with flow meter.
Direct reading of flow rate.
Cast iron body. Brass flow meter.
Ball valve for flow rate adjustment with contoured inside.
Graduated scale flow meter with magnetic movement flow rate indicator.
Flanged PN 16 connections.
Coupling with counterflange EN 1092-1. PATENT.

Code		Flow rate range (m³/h)
132060	DN 65	6–24
132080	DN 80	8–32
132100	DN 100	12–48

Flow meter for flow rate measurement

Flow rate measurement is provided directly by a flow meter, housed in a by-pass circuit on the device body, which can be automatically excluded during normal operation.

Main applications - Manual balancing valves with flow meter

- ✓ constant flow rate circuits, with limited extension
- ✓ domestic hot water recirculation circuits

- ✓ circuits with closely spaced pipes, for easy reading and setting

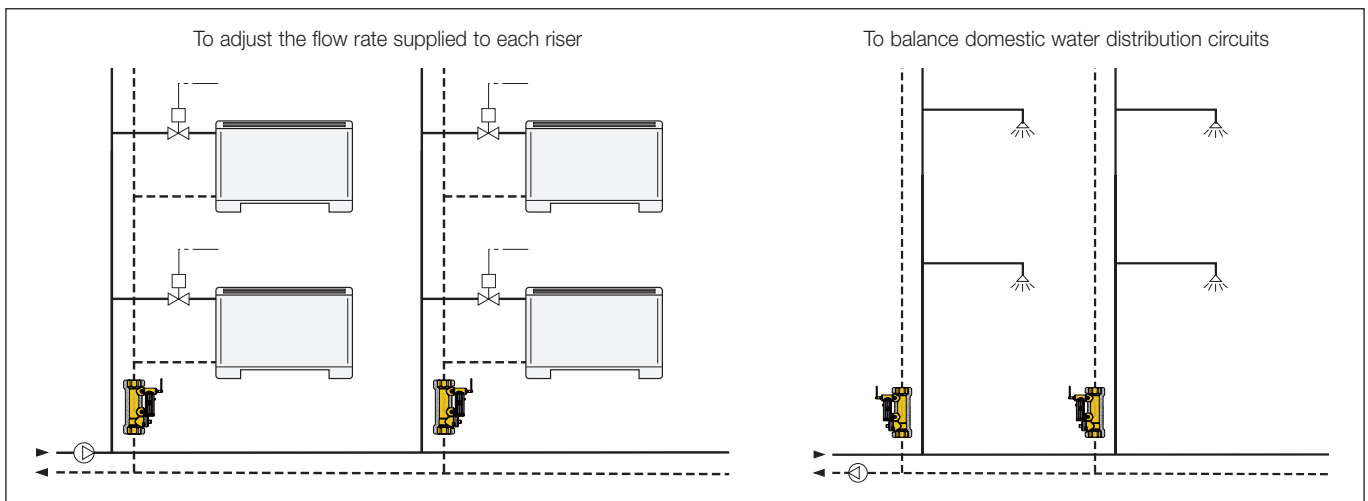

STATIC BALANCING - DYNAMIC BALANCING

Unbalanced circuits have characteristics such as to create problems in distributing the flow rates to the terminals. To overcome these problems it is normal practice to fit two types of balancing device:

- **static devices.** These are conventional devices suitable for use in constant flow rate circuits or circuits subject to limited load variations.
- **dynamic devices.** Modern automatic devices, mainly suitable for variable flow rate systems with thermal loads that change frequently.

Unbalanced circuits

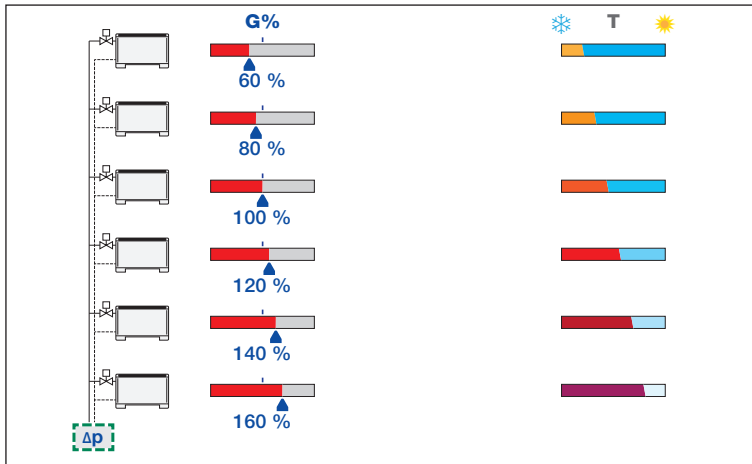

In unbalanced circuits, the hydraulic imbalance between terminals creates areas with non-uniform temperatures, resulting in problems with thermal comfort and higher energy consumption.

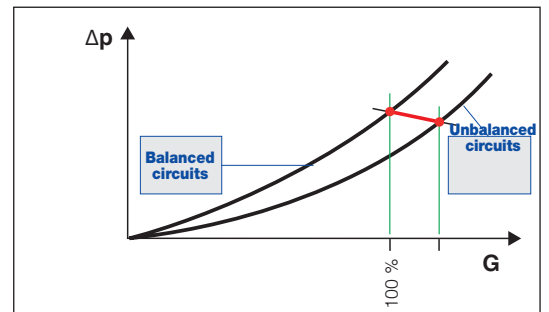

Static balancing

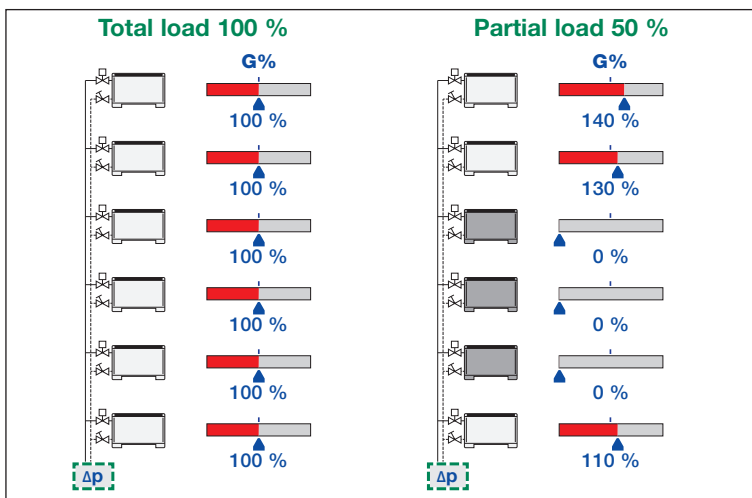

Traditionally, hydraulic circuits are balanced using manual setting valves. With these static devices, these circuits are difficult to balance perfectly and have **operating limitations** in the event of partial closure by means of the regulating valves. The flow rate in the open circuits **does not remain constant at the nominal value.**

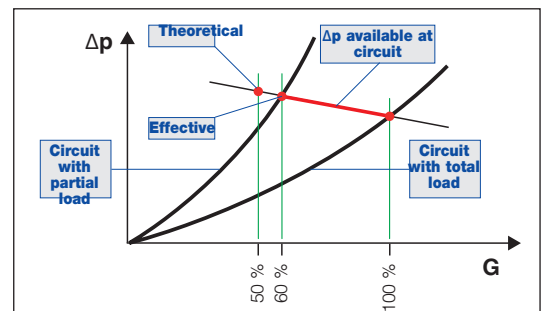

Dynamic balancing

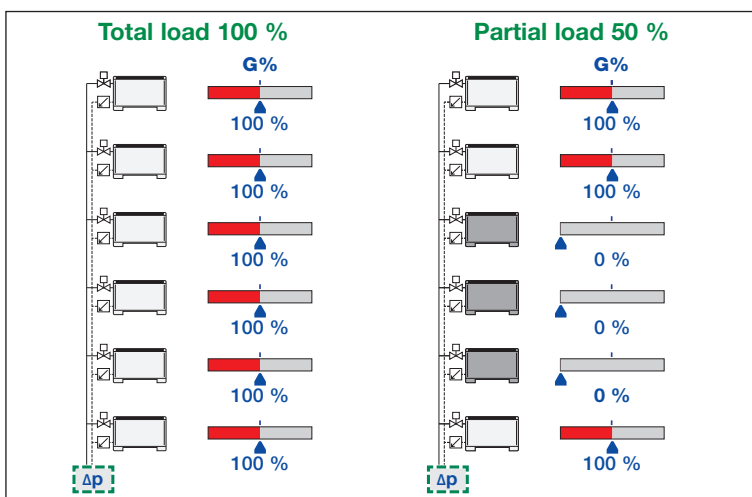

Dynamic devices can balance the hydraulic circuit automatically, ensuring each terminal receives the design flow rate. Even when the regulating valves close the circuit partially, the flow rates in the open circuits **remain constant at the nominal value.** The system always guarantees the greatest comfort and the highest energy savings.

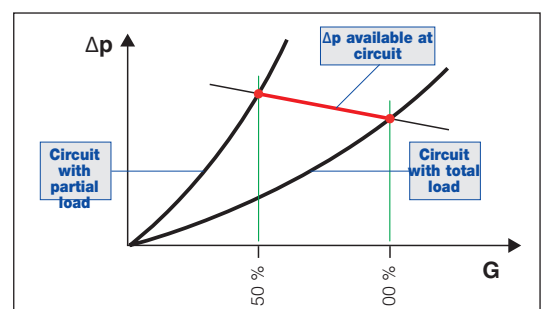

Dynamic balancing devices

- Automatic variable flow rate regulator, fixed flow rate

127-128-121-126 series

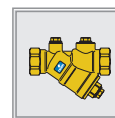

127 tech. broch. 01166 AUTOFLOW®

Compact automatic flow rate regulator. Brass body. PATENT.

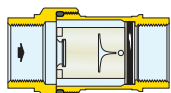

Cartridge: 1/2"–1 1/4" high-strength polymer, 1 1/2" and 2" high-strength polymer and stainless steel.

Code	Flow rates (m³/h)		
127141 ...	DN 15	1/2"	0.02– 1.4
127151 ...	DN 20	3/4"	0.02– 1.6
127161 ...	DN 25	1"	0,5 – 5,0
127171 ...	DN 32	1 1/4"	0,5 – 5,0
127181 ...	DN 40	1 1/2"	4,5 –11,0
127191 ...	DN 50	2"	4,5 –11,0



128 tech. broch. 01269 AUTOFLOW®

Compact automatic flow rate regulator. Brass body. AUTOFLOW® cartridge in high-performance polymer.

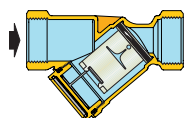

Code	Flow rates (m³/h)	
128141 ...	1/2"	0.02–1.2
128151 ...	3/4"	0.02–1.4
128161 ...	1"	0,5 –5,0
128171 ...	1 1/4"	0,5 –5,0



Insulation for AUTOFLOW® 128 series.

Code	Utilisation
CBN128141 ...	128141-128151
CBN128161 ...	128161-128171



121 tech. broch. 01141 AUTOFLOW®

Combination of automatic flow rate regulator and ball valve. CR dezincification resistant alloy body. PATENT.

Cartridge: 1/2"–1 1/4" high-strength polymer, 1 1/2" and 2" high-strength polymer and stainless steel.

Code	Flow rates (m³/h)		
121141 ...	DN 15	1/2"	0.085– 1.2
121151 ...	DN 20	3/4"	0.085– 1.6
121161 ...	DN 25	1"	0,5 – 5,0
121171 ...	DN 32	1 1/4"	0,5 – 5,0
121181 ...	DN 40	1 1/2"	5,5 –11,0
121191 ...	DN 50	2"	5,5 –11,0



126 tech. broch 01141 AUTOFLOW®

Automatic flow rate regulator. CR dezincification resistant alloy body. PATENT.

Cartridge: 1/2"–1 1/4" high-strength polymer, 1 1/2" and 2" high-strength polymer and stainless steel.

Code	Flow rates (m³/h)		
126141 ...	DN 15	1/2"	0.085– 1.2
126151 ...	DN 20	3/4"	0.085– 1.6
126161 ...	DN 25	1"	0,5 – 5,0
126171 ...	DN 32	1 1/4"	0,5 – 5,0
126181 ...	DN 40	1 1/2"	5,5 –11,0
126191 ...	DN 50	2"	5,5 –11,0

For the choice of single flow rates, Δp range and complete code, refer to the price list or technical brochure.

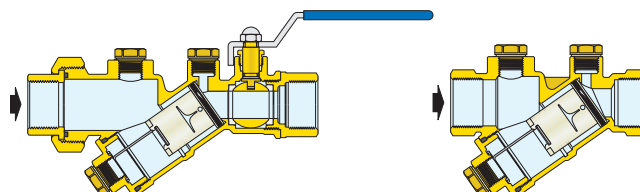

Technical specifications

series ⇄	127	121-126	128
Performance			
Medium:	water, glycol solutions	water, glycol solutions	water, glycol solutions
Max. percentage of glycol:	50 %	50 %	50 %
Maximum working pressure:	16 bar	25 bar	16 bar
Working temperature range:	0–100 °C	-20–100 °C	0–100 °C
Δp range:	15–200 kPa and 20–200 kPa	15–200 kPa	15–200 kPa and 20–200 kPa
Accuracy:	± 10 % and ± 15 %	±10 %	± 10 % and ± 15 %

Dynamic balancing devices

Operating principle

The regulating element of these devices consists of a cylinder and a piston which has dedicated lateral openings with fixed and variable geometry through which the medium flows. These openings are governed by the piston movement, on which the pressure of the medium acts. A specially calibrated spring counteracts this movement.

AUTOFLOW® devices are high-performance automatic regulators. They regulate the chosen flow rates within very tight tolerances (approximately 10 %) and offer an unusually wide working range.

The flow rate regulating element is made entirely of high resistance polymer, specially chosen for use in heating and cooling systems and hydraulic and domestic water systems. It offers excellent mechanical behaviour over a wide range of working temperatures, features high abrasion resistance because the medium flows continuously, is insensitive to limescale deposits and is fully compatible with the glycols and additives used in circuits.

Within the working range

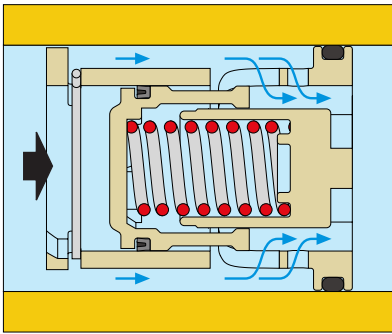

If the differential pressure is within the working range, the piston compresses the spring and gives the medium a free flow area to permit normal flow at the **nominal flow rate** for which the AUTOFLOW® is set.

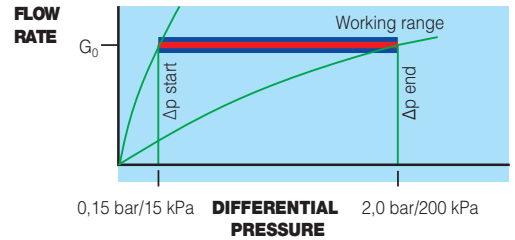
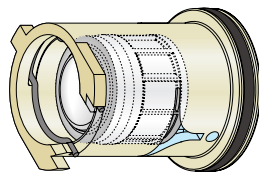

Main applications - AUTOFLOW® automatic flow rate regulators

- ✓ variable flow rate circuits with two-way regulating valves and complex extended networks
- ✓ circuits with adjustment at the terminal, with two-way valves
- ✓ circuits with ON/OFF or modulating flow rate adjustment
- ✓ circuits supplying AHU coils in air based or air-water systems

To use in line with various types of heat emitters: radiators, convectors, fan-coils, unit heaters, thermal strips, etc.

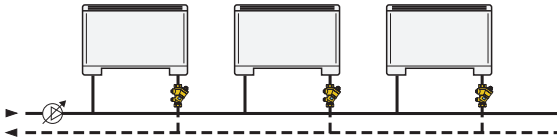

To ensure the required amount of medium flows through each terminal

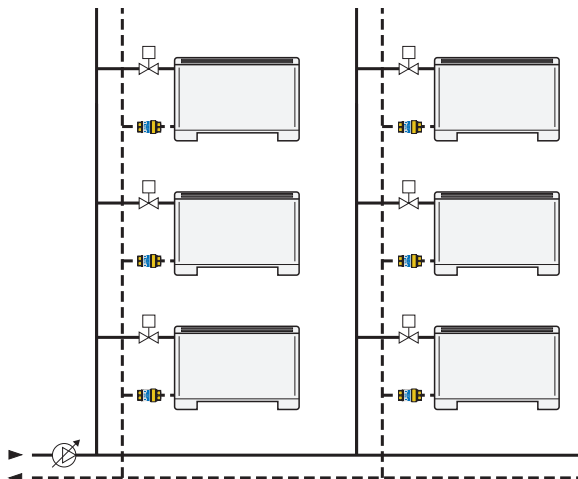

To balance domestic water distribution circuits

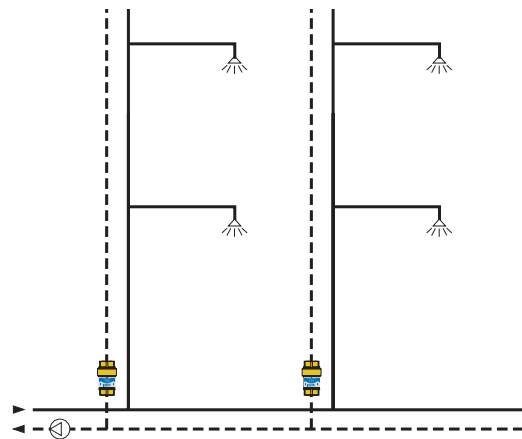

To adjust the flow rate to each riser or secondary branch of a system

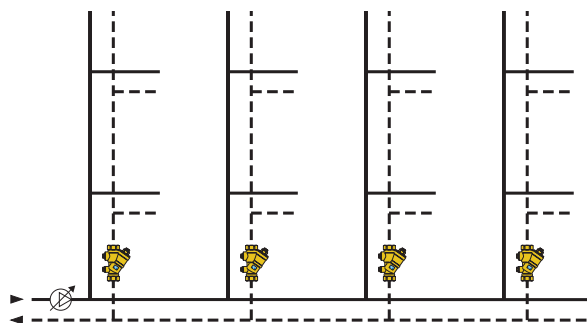

- Automatic flow rate regulator, fixed flow rate

120-125-103 series

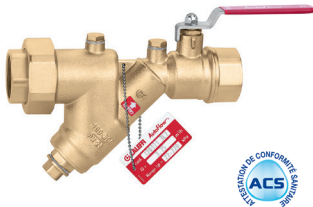
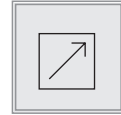

120 AUTOFLOW®

tech. broch. 01041

Combination of automatic flow rate regulator and ball valve. **CR** dezincification resistant alloy body. Stainless steel filter cartridge.



Code	DN	Flow rates (m³/h)
120141 ...	DN 15 1/2"	0.12– 2.75
120151 ...	DN 20 3/4"	0.12– 2.75
120161 ...	DN 25 1"	0,7 – 6,0
120171 ...	DN 32 1 1/4"	0,7 – 6,0
120181 ...	DN 40 1 1/2"	2,75–15,5
120191 ...	DN 50 2"	2,75–15,5



125 AUTOFLOW®

tech. broch. 01041

Automatic flow rate regulator. Dezincification resistant alloy body **CR**.



Stainless steel filter cartridge.

Code	DN	Flow rates (m³/h)
125141 ...	DN 15 1/2"	0.12– 2.75
125151 ...	DN 20 3/4"	0.12– 2.75
125161 ...	DN 25 1"	0,7 – 6,0
125171 ...	DN 32 1 1/4"	0,7 – 6,0
125181 ...	DN 40 1 1/2"	2,75–15,5
125191 ...	DN 50 2"	2,75–15,5
125101 ...	DN 65 2 1/2"	6,5 –22

For the choice of single flow rates, Δp range and complete code, refer to the price list or technical brochure.

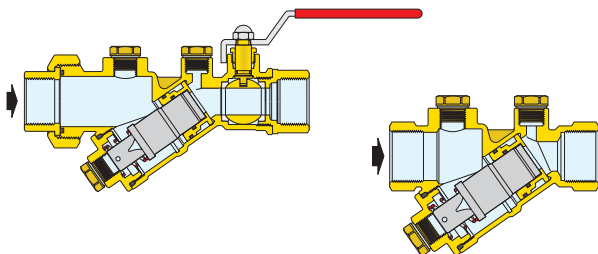

103 AUTOFLOW® flanged

tech. broch. 01041

Automatic flow rate regulator. Cast iron body. Stainless steel filter cartridge. Supplied complete with EN 1092-1 PN 16 flanges, rods, seals and quick-fit pressure test ports.

Code	DN	Minimum working Δp (kPa)	Flow rates (m³/h)	Δp range (kPa)
103111 ...	65	22	9– 17	22–210
103113 ...	65	40	18– 23	40–390
103114 ...	65	55	25– 36	55–210
103121 ...	80	22	9– 17	22–210
103123 ...	80	40	18– 23	40–390
103124 ...	80	55	25– 36	55–210
103231 ...	100**	22	18– 34	22–210
103233 ...	100**	40	23– 45	40–390
103234 ...	100**	55	50– 73	55–210
103141 ...	125	22	18– 34	22–210
103143 ...	125	40	23– 45	40–390
103144 ...	125	55	50– 73	55–210
103151 ...	150	22	40– 68	22–210
103153 ...	150	40	40– 91	40–390
103154 ...	150*	55	92–145	55–210
103161 ...	200*	22	80–119	22–210
103163 ...	200*	40	80–159	40–390
103164 ...	200*	55	160–255	55–210
103171 ...	250*	22	110–187	22–210
103173 ...	250*	40	110–250	40–390
103174 ...	250*	55	251–400	55–210
103181 ...	300*	22	150–255	22–210
103183 ...	300*	40	150–341	40–390
103184 ...	300*	55	342–545	55–210

* Supplied with ANSI flange

** Available with EN 1092-1 PN 25 flanges on request, size DN 100

To identify AUTOFLOW® devices, contact Caleffi technical support in advance.

They are available on request with sizes of from DN 350 to DN 1000, with flow rates of up to 4400 m³/h.

Minimum differential pressure required

This is the same as the minimum working Δp of the AUTOFLOW® cartridge (22, 40 or 55 kPa).

$$\text{Pump head } H = \Delta p_{\text{circuit}} + \Delta p_{\text{required}}$$

Technical specifications

series ↔	120	125	103
Performance			
Medium:	water, glycol solutions	water, glycol solutions	water, glycol solutions
Max. percentage of glycol:	50 %	50 %	50 %
Maximum working pressure:	25 bar	25 bar	16 bar
Working temperature range:	0–110 °C	-20–110 °C	-20–110 °C
Δp range:	10–95 kPa; 22–210 kPa; 40–390 kPa	10–95 kPa; 22–210 kPa; 40–390 kPa	22–210 kPa; 40–390 kPa; 55–210 kPa
Accuracy:	± 5 %	± 5 %	± 5 %

Dynamic balancing devices

Operating principle

The regulating element of these devices consists of a piston and a cylinder which has, fixed and variable geometry side-opening pipe sections through which the medium flows. These openings are governed by the piston movement, on which the pressure of the medium acts. A specially calibrated spring counteracts this movement.

AUTOFLOW® devices are high-performance automatic regulators. They regulate the chosen flow rates within very tight tolerances (approximately 5 %) and offer an unusually wide working range.

Within the working range

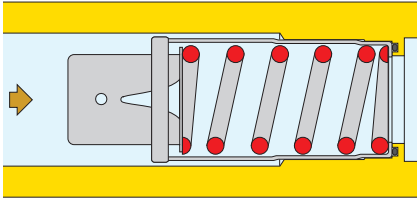

If the differential pressure is within the working range, the piston compresses the spring and gives the medium a free flow area to permit normal flow at the **nominal flow rate** for which the AUTOFLOW® is set.

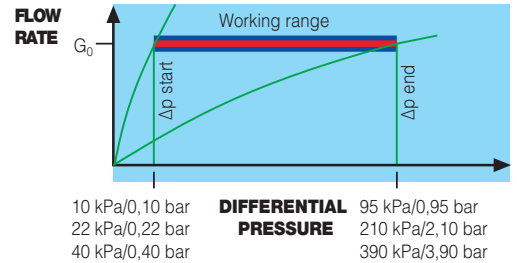
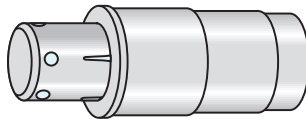

Main applications - AUTOFLOW® automatic flow rate regulators

- ✓ variable flow rate circuits with two-way regulating valves and complex extended networks
- ✓ circuits with adjustment at the terminal, with two-way valves
- ✓ circuits with ON/OFF or modulating flow rate adjustment
- ✓ circuits supplying AHU coils in air based or air-water systems
- ✓ district heating circuits for control of the primary side of the substations

To balance circuits that serve air handling units

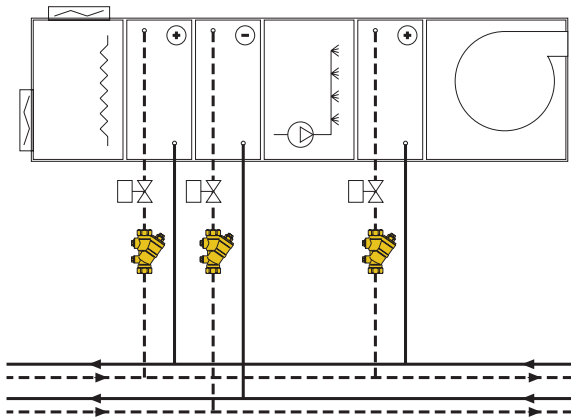

To balance the circuits that serve chiller unit evaporators or condensers

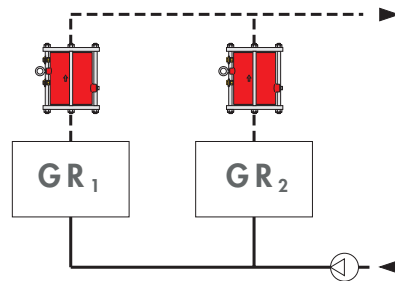

To balance circuits serving cooling towers

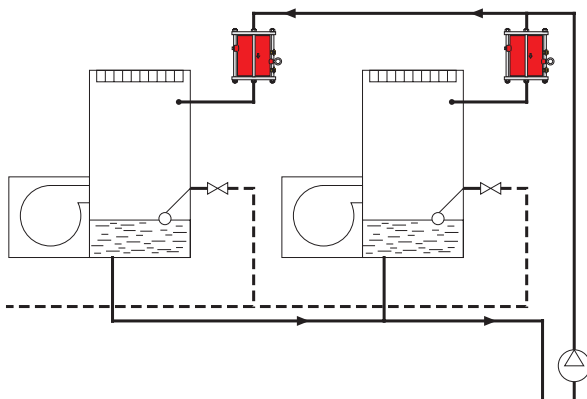

To ensure the required amount of medium flows through each terminal

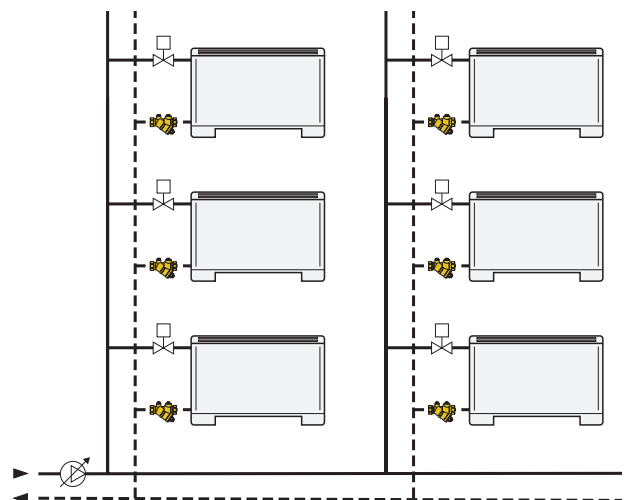

DYNAMIC BALANCING AND REGULATION

If the two functions of dynamic balancing and regulation are combined in the same device, the hydraulic circuit is **balanced with continuous control of thermal loads**. All the circuits supplied remain independent and the flow rate remains constantly at the value corresponding to each partial load, irrespective of the operating conditions of the circuit. Flow rate modulation to the necessary value for each circuit is not affected by the closure or capacity control of the other circuits.

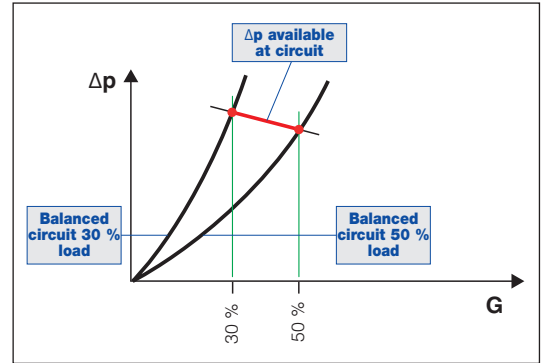
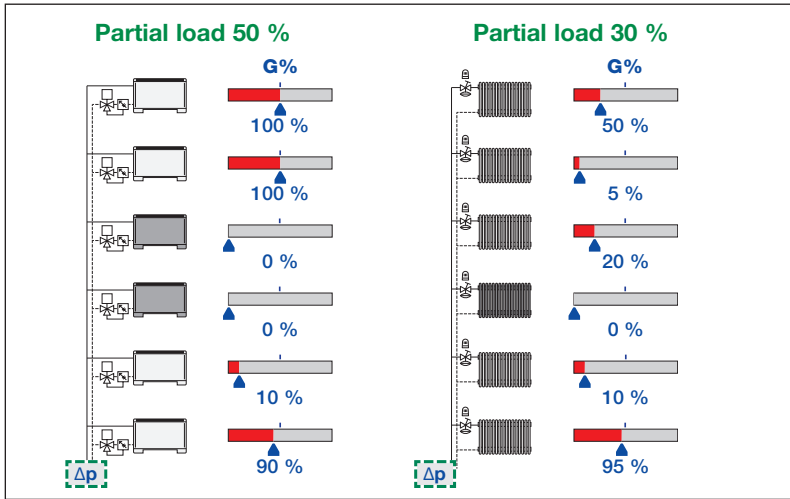

Dynamic balancing and regulating devices

- Pressure independent control valve (PICV)

145 series

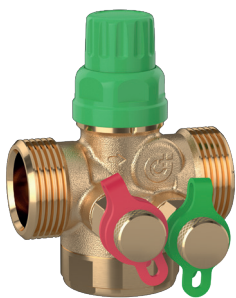
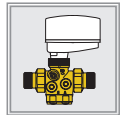
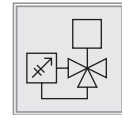

145 FLOWMATIC®  tech. broch. 01262
 FLOWMATIC® pressure independent control valve. **CR** dezincification resistant alloy body. Composite flow rate regulator with EPDM diaphragm. Graduated scale indicator. Complete with pressure test ports. Threaded male connections. **Can be used in conjunction with actuators code 145013 and 6565 series thermo-electric actuators.**

Code	DN	Connection	Flow rate range (m³/h)
145437 H20	15	1/2"	0.02–0.20
145447 H20	15	3/4"	0.02–0.20
145447 H40	15	3/4"	0.08–0.40
145447 H80	15	3/4"	0.08–0.80
145557 H20	20	1"	0.02–0.20
145557 H40	20	1"	0.08–0.40
145557 H80	20	1"	0.08–0.80
145557 1H2	20	1"	0.12–1.20
145667 1H8	25	1 1/4"	0.18–1.80
145667 3H0	25	1 1/4"	0,30–3,00
145667 3H7	25	1 1/4"	0,37–3,70

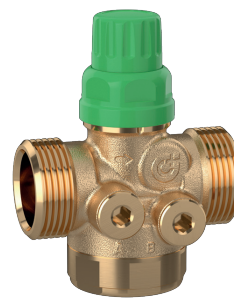

145 FLOWMATIC®  tech. broch. 01262
 FLOWMATIC® pressure independent control valve. **CR** dezincification resistant alloy body. Composite flow rate regulator with EPDM diaphragm. Graduated scale indicator. Designed for pressure test ports connection. Threaded male connections. **Can be used in conjunction with actuators code 145013 and 6565 series thermo-electric actuators.**

Code	DN	Connection	Flow rate range (m³/h)
145434 H20	15	1/2"	0.02–0.20
145444 H20	15	3/4"	0.02–0.20
145444 H40	15	3/4"	0.08–0.40
145444 H80	15	3/4"	0.08–0.80
145554 H20	20	1"	0.02–0.20
145554 H40	20	1"	0.08–0.40
145554 H80	20	1"	0.08–0.80
145554 1H2	20	1"	0.12–1.20
145664 1H8	25	1 1/4"	0.18–1.80
145664 3H0	25	1 1/4"	0,30–3,00
145664 3H7	25	1 1/4"	0,37–3,70

Technical specifications

145 series flow rate control valve performance

Medium: water, glycol solutions
 Maximum percentage of glycol: 50 %
 Maximum working pressure: 25 bar
 Maximum differential pressure with actuator code 145013 and 6565 series thermo-electric actuators: 4 bar
 Working temperature range: -20–120 °C
 Nominal Δp operating range: 25–400 kPa
 Accuracy: 5 % of the set point



Insulation for FLOWMATIC® 145 series.

Code	Utilisation
CBN145437	DN 15 - DN 20
CBN145667	DN 25

145 FLOWMATIC®

 tech. broch. 01262



Proportional linear actuator for 145 series FLOWMATIC® flow rate control valve and 149 series kit.
 Electric supply: 24 V (AC)/(DC).
 Control signal:
 0(2)–10 V, 0 (4)–20 mA, 0–5 V, 5–10 V.
 Feedback signal: 0–10 V.
 Ambient temperature range: 0–50 °C.
 Protection class: IP 54.
 Connection: M 30 p.1,5.
 Supply cable length: 1.5 m.

Code	Voltage V	Control signal	Feedback signal
145013	24	0–10 V	0–10 V

6565

 tech. broch. 01262



Proportional thermo-electric actuator for 145 series FLOWMATIC® flow rate regulating valves and 149 series kits.
Quick-coupling installation with fixing clip adapter. Normally closed.
 Electric supply: 24 V (AC)/(DC).
 Control signal: 0–10 V.
 Feedback signal: 0–10 V.
 Running power consumption: 1.2 W.
 Ambient temperature range: 0–60 °C.
 Protection class: IP 54.
 Connection: M 30 p.1,5.
 Supply cable length: 1 m.

Code	Voltage V	Control signal	Feedback signal
656524	24	0–10 V	0–10 V

145

tech. broch. 01367



Proportional linear actuator for 145 series FLOWMATIC® flow rate control valve and 149 series kit.
 Electric supply: 24 V (AC)/(DC).
 Control signal:
 2-point, 3-point, 0–10 V.
 Feedback signal: 0–10 V.
 With manual override.
 Ambient temperature range: 0–50 °C.
 Protection class: IP 54.
 Connection: M 30 p.1,5.
 Supply cable length: 1.5 m.

Code	Voltage V
145019	24

6565/6566

 tech. broch. 01262



Thermo-electric actuator for 145 series FLOWMATIC® flow rate regulating valves and 149 series kits.
Quick-coupling installation, with fixing clip adapter. Normally closed.
 Electric supply: 230 V (AC) or 24 V (AC)/(DC).
 Control signal: ON/OFF.
 Running power consumption: 1 W.
 Ambient temperature range: 0–60 °C.
 Protection class: IP 54.
 Connection: M 30 p.1,5.
 Supply cable length: 1 m.

Code	Voltage V	Control signal	
656502	230	ON/OFF	Normally closed
656504	24	ON/OFF	Normally closed
656602	230	ON/OFF	Normally open
656604	24	ON/OFF	Normally open

145

tech. broch. 01367



Proportional linear actuator for 145 FLOWMATIC® series control valve and 149 series kits.
 Electric supply: 24 V (AC)/(DC).
 Control signal:
 2-point, 0–10 V.
 Feedback signal: 0–10 V.
With fail-safe function.
 Ambient temperature range: 0–50 °C.
 Protection class: IP 54.
 Connection: M 30 p.1,5.
 Supply cable length: 1.5 m.

Code	Voltage V
145018	24

145

Flat seat union complete with seal for 145 series in brass

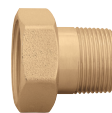

Code	
145001	1/2" F x 3/8" M
145003	3/4" F x 1/2" M
145005	1" F x 3/4" M
145006	1" F x 1" M
145007	1 1/4" F x 1" M
145008	1 1/4" F x 1 1/4" M

Operating principle

The pressure independent control valve (PICV) is designed to regulate a medium flow rate that is:
 - adjustable in accordance with the requirements of the part of the circuit controlled by the device;
 - constant despite any variation in differential pressure conditions in the circuit.
 The device layout is shown in the diagram below:

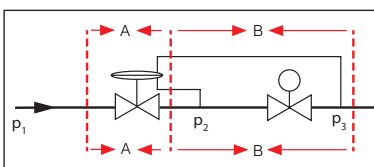

Where:
 p_1 = upstream pressure
 p_2 = intermediate pressure
 p_3 = downstream pressure
 $(p_1 - p_3) = \text{total valve } \Delta p$

Working range

For the device to keep the flow rate constant regardless of the circuit differential pressure conditions, total valve Δp ($p_1 - p_3$) must be in the range from the minimum Δp value and the maximum value of 400 kPa.

Dynamic balancing and regulating devices

Concisely:

Since $G = K_v \times \sqrt{\Delta p}$

- by manually or automatically adjusting device B, the K_v value and consequently the G value can be set;
- once G value has been set, it remains constant thanks to the action of (A), which keeps $(P_2 - P_3) = \text{const.}$ in response to circuit pressure changes.

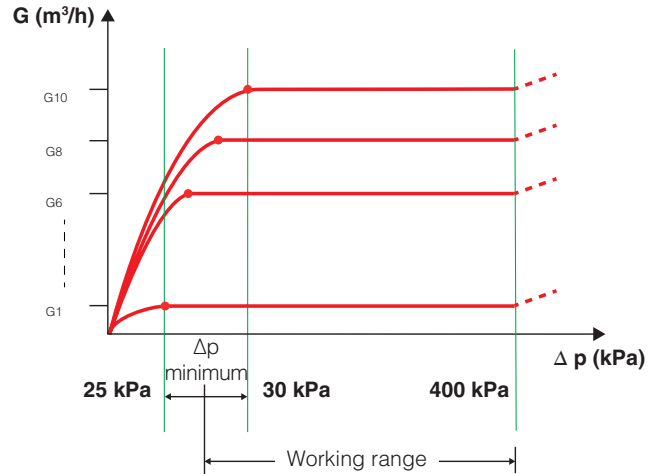
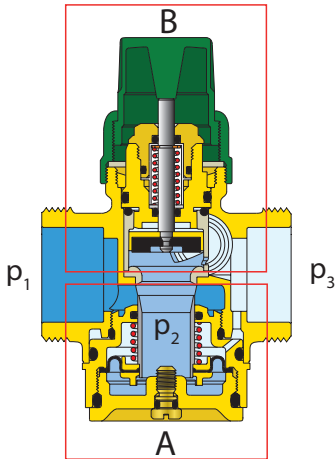

Adjustment procedure

Maximum flow rate regulation

Unscrew the protective cap by hand to gain access to the maximum flow rate adjustment nut (1), which can be turned with a hexagonal key. The locking nut is fixed to a 10-position graduated scale, divided into steps corresponding to 1/10 of the maximum available flow rate, which is also shown on the scale (3). Turn the locking nut to the numerical position corresponding to the required flow rate (design flow rate), referring to the "Flow rate adjustment table" in the technical brochure. The slot (2) on the valve body is the physical positioning reference.

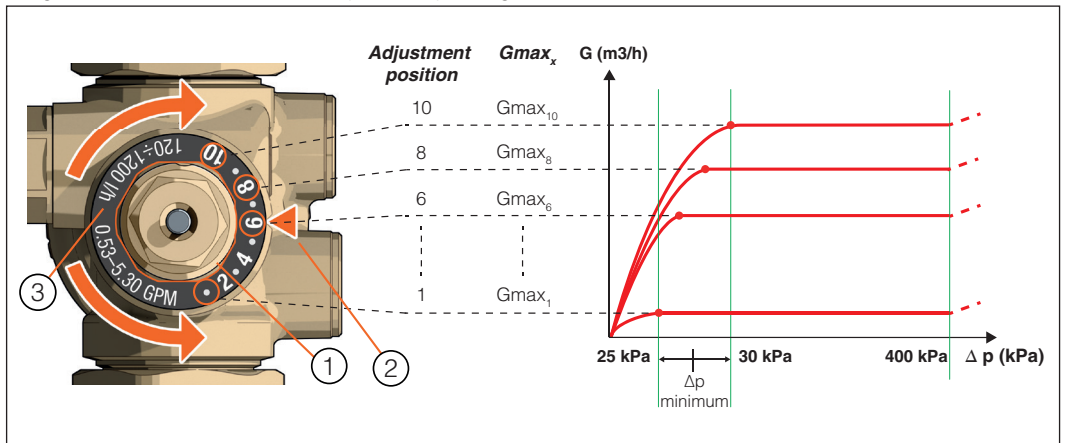

Automatic flow rate regulation with actuator and external regulator

After regulating the maximum flow rate, fit the actuator (0-10 V) to the valve (7). Under the control of an external regulator the actuator can automatically adjust the flow rate from the maximum set value (e.g: G_{max_8}) to the minimum value in accordance with the thermal load to be controlled. The actuator acts on the vertical displacement of the control stem (5). This results in additional opening/closing, on the maximum bore cross section, by the internal obturator (6).

Valve regulating characteristics

The valve regulating characteristic is of the linear type. An increase or decrease in the valve opening cross section corresponds to a directly proportional increase or decrease of the hydraulic characteristic K_v of the device. The motor is factory set with linear adjustment. It is possible to obtain an equal-percentage adjustment (see diagram below) by setting the actuator (code 14501.) for this operation using the dedicated switch inside it. (see specific instruction sheet). In this way the control signal is managed to obtain an equal percentage adjustment.

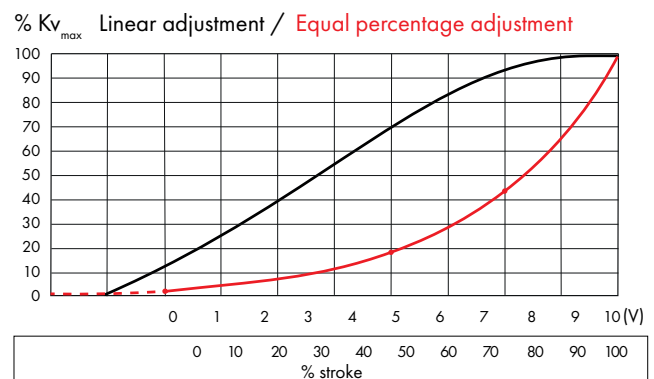
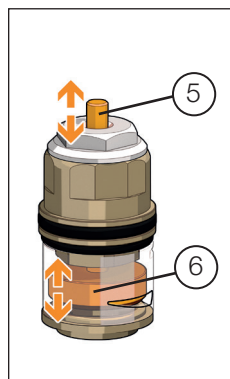
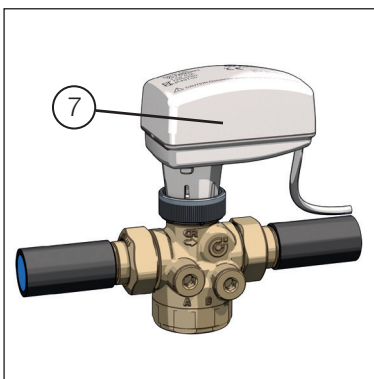

Dynamic balancing and regulating devices



145

Pressure independent control valve.
Cast iron body.
Maximum working pressure: 25 bar.
Working temperature range: -10–120 °C.
Maximum percentage of glycol: 50 %.
 Δp range: 30–600 kPa.
With pressure test ports.

Code	DN	Connection	Flow rate ranges (m ³ /h)
145895	40	2" M	2,9– 9,3
145905	50	2 1/2" M	5.1–14.8

Flat seat union complete with seal for 145 series in cast iron.

Code	
145009	2"F x 1 1/2"M
145010	2 1/2"F x 2"M



145

Proportional rotary actuator for 145 series flow rate regulating valves.
Electric supply: 24 V (AC)/(DC).
Control signal: 2–10 V.
Feedback signal: 2–10 V.
Ambient temperature range: -30–50 °C.
Protection class: IP 54.
Manual override.

Code	Voltage V	Control signal	Feedback signal	Utilisation
145017	24	2–10 V	2–10 V	DN 40 - DN 50



Code	
146001	

146

Manual actuator for 145895 and 145905 valves.

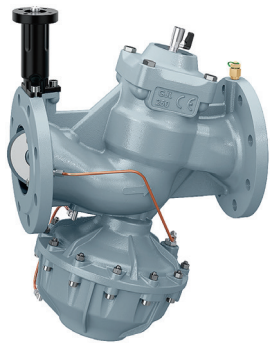

146

Pressure independent control valve.
Grey cast iron body.
Maximum working pressure: 16 bar.
Working temperature range: -10–120 °C.
Maximum percentage of glycol: 50 %.
 Δp range: 30–400 kPa.
With pressure test ports.
Flanged PN 16 connections.
To be coupled with flat counterflange EN 1092-1.

Code	DN	Flow rate ranges (m ³ /h)
146060	65	6– 26
146080	80	8– 36
146100	100	16– 82,5
146120	125	20–125
146150	150	27– 16

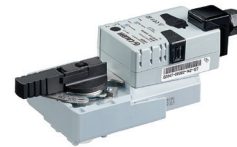

146

Proportional rotary actuator for 146 series flow rate control valves.
Electric supply: 24 V (AC)/(DC).
Control signal: 2–10 V.
Feedback signal: 2–10 V.
Ambient temperature range: -30–50 °C.
Protection class: IP 54.
Manual override.

Code	Voltage V	Control signal	Feedback signal	Utilisation
146025	24	2–10 V	2–10 V	DN 65–DN 150



Code	
146000	

146

Manual actuator for 146 series regulating valve.

Regulating characteristics (linear)

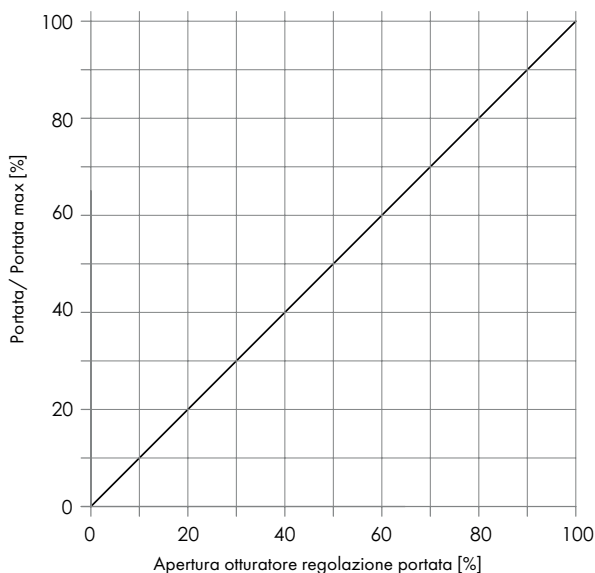

After installing the rotary actuator or manual actuator on the valve body, valve adjustment takes place by setting the maximum flow rate value using the graduated knob.

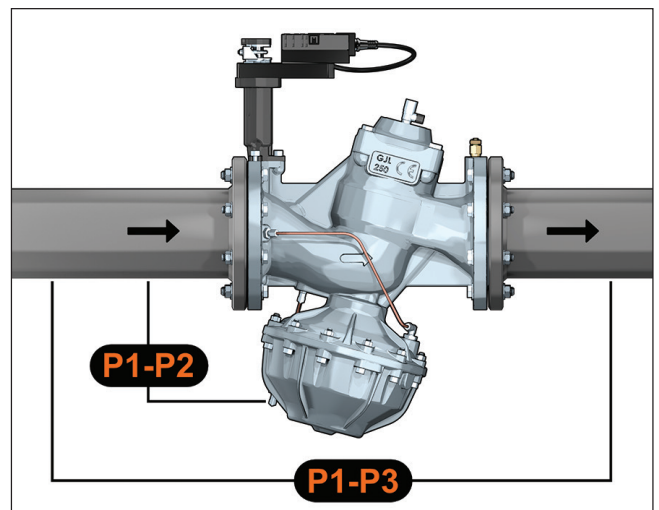

Dynamic balancing and regulating devices

Main applications - Pressure independent control valve

- ✓ variable flow rate circuits with adjustment on the terminal, in complex extended networks
- ✓ circuits with modulating flow rate control, with limited adjustment requirements
- ✓ circuits controlled by building automation systems
- ✓ circuits supplying AHU coils in air based or air-water systems

To use in line with various types of heat emitters: radiators, convectors, fan-coils, unit heaters, thermal strips, etc.

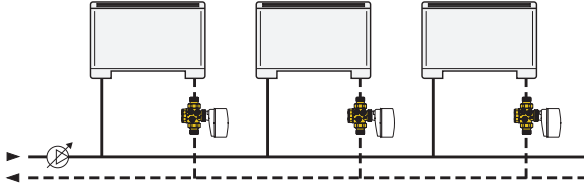

To ensure the required amount of medium flows through each terminal

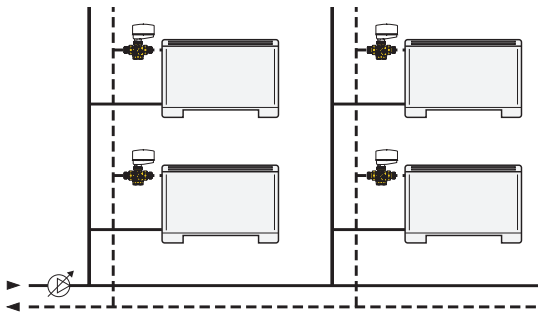

To balance circuits that serve air handling units

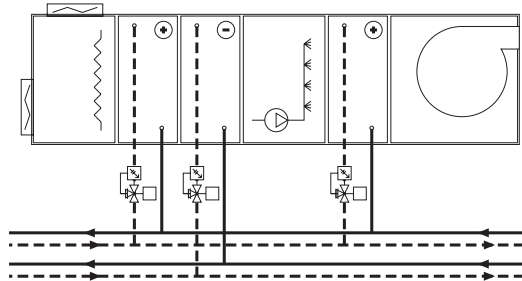

To guarantee the design flow rates (with open or closed valve) to the various zones of a system

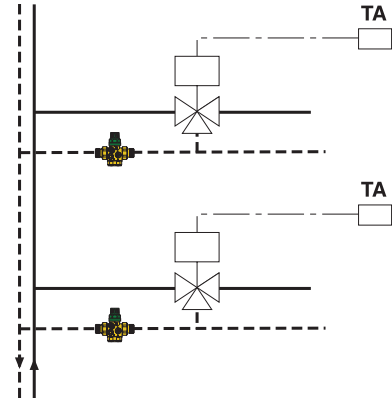

To adjust flow rate in applications with cooling beams

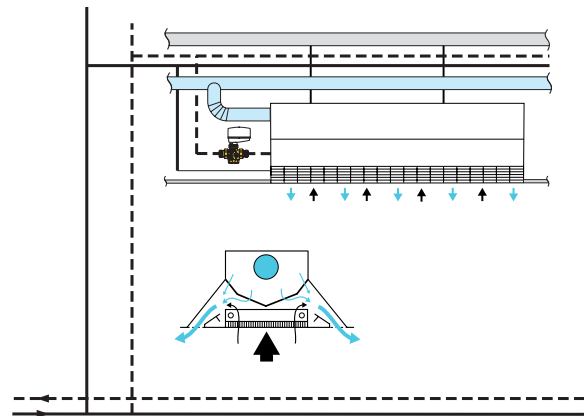

- Connection and regulation kit for HVAC terminal units

149 series

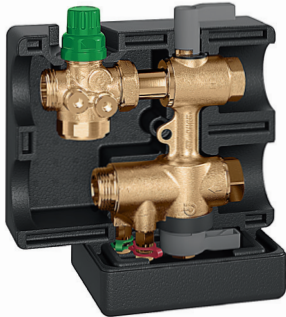
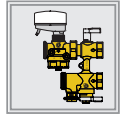
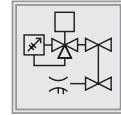

 tech. broch. 01336

Function

The connection kit is a pre-assembled compact unit designed to control, adjust and filter the circuit of the terminal unit. It also allows to perform maintenance and setting operations of the system.

It allows the connection of fan-coils, cooling beams or ceiling-mounted air-conditioning systems to the main distribution system. Complete with insulation suitable for both heating and cooling.

Product range

149 series Connection and regulation kit

sizes DN 15 (1/2" F x 3/4" M), DN 20 (3/4" F x 1" M), DN 25 (1" F x 1 1/4" M)

Performance

Medium:	water, glycol solutions	Working temperature range:	-10–120 °C
Maximum percentage of glycol:	50 %	Nominal Δp operating range (PICV):	25–400 kPa
Maximum working pressure:	25 bar	Flow rate regulation range:	0,02–3,70 m ³ /h
Maximum differential pressure with actuators code 145013 and 6565 series actuator:	4 bar	PICV accuracy:	± 5 % of the set point
		Leakage:	class V in accordance with EN 60534-4
		For the choice of individual models, please refer to the technical brochure.	

Characteristic components

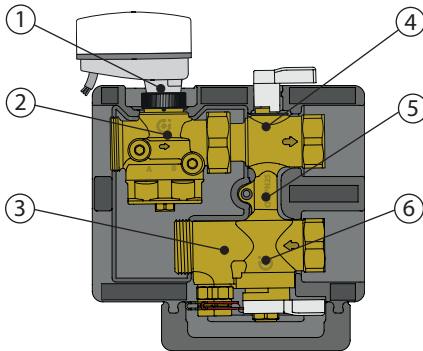

1. Actuator (optional)
2. Pressure independent control valve (PICV)
3. Venturi device for flow rate measurement with connections for pressure test ports for flow rate measurement (present only in 149.00 codes)
4. Three-way shut-off valve
5. By-pass
6. Shut-off valve with built-in strainer

The kit allows you to:

- adjust and maintain the flow rate of the terminal unit at a constant value as the differential pressure conditions of the main circuit changes due to the pressure independent control valve PICV (2);
- isolate the terminal unit through the three-way shut-off valves (5-7);
- bypass the flow through the three-way shut-off valves (5-7) and the built-in by-pass (6);

The device layout is shown in the diagram below:

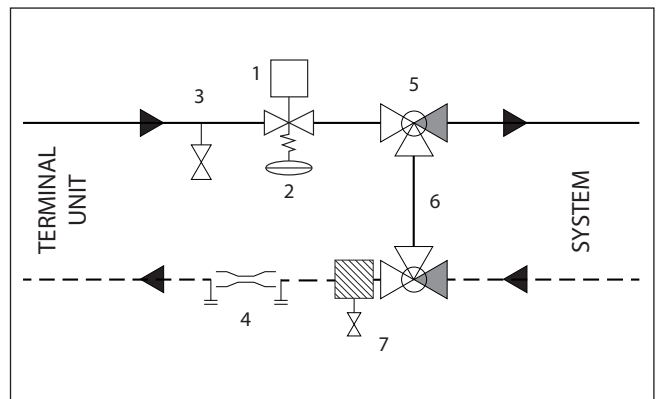

- filter the inlet water to the terminal unit through the strainer located inside the shut-off valve (7);
- measure the flow rate passing through the terminal unit using the Venturi device and the pressure test ports (4), which make it easy to connect the measuring instrument (in 149.00 codes only);
- clean the circuit and drain the water through the built-in drain cock or the optional adjustable cock (3).

Construction details

Compact body

The kit is designed specifically for small dimensions, compact and easy to install to facilitate the terminal unit connection to the main circuit.

Individual components assembled in site

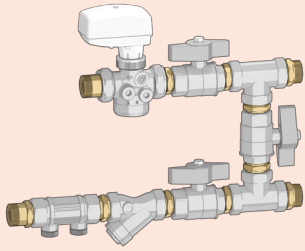

20 hydraulic connections

Laborious installation and with high risk of hydraulic leakage



Pre-assembled group

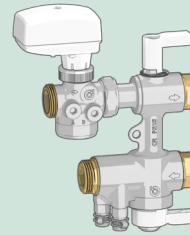

4 hydraulic connections

Ease of installation and low risk of hydraulic leakage

Three-way ball shut-off valve

The shut-off valves have been designed with three ways to minimise the dimensions and connections of the kit. The internal ball is designed to open the straight path (for normal operation), the by-pass path (for passage through the by-pass) or to completely close the passage and isolate the circuit of the terminal unit.

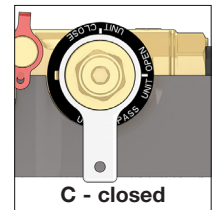
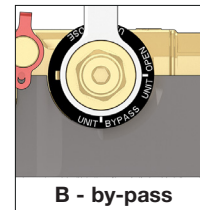
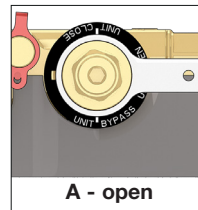

Integrated by-pass

The kit is equipped with a by-pass, which is an indispensable element for each terminal circuit. The by-pass allows to:

- perform the flushing, washing and cleaning operations of the main circuit pipes without the medium passing through the terminal unit;
- shut off and carry out maintenance operations on the terminal unit.

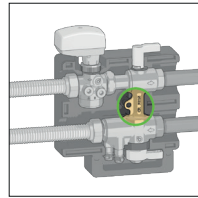

Built-in strainer

The cartridge strainer in the kit mechanically blocks the impurities in the thermal medium (before they reach the terminal unit) and captures them by mechanical selection through a specific metal filter mesh.

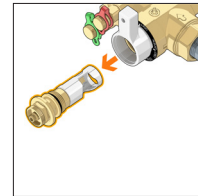
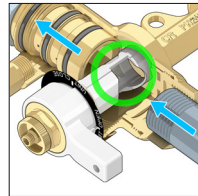

Built-in PICV (145 series)

The kit is equipped with a pressure independent control valve (PICV) capable of adjusting and maintaining the constant the flow rate even when the differential pressure conditions of the terminal unit changes. (see page 16)

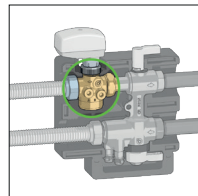

Flow rate meter (in the predisposed versions)

The kit can be finished with a flow rate metering device based on the Venturi effect. The possibility of measuring the flow rate in a simple way facilitates system setting and commissioning operations.

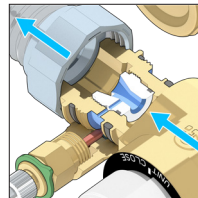

drain cock with rubber hose

The kit is complete with drain cock and rubber hose for flushing and draining.

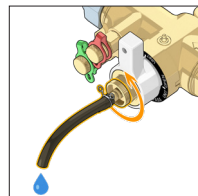

Bracketing

The unit has a facility for bracketing with threaded bar.

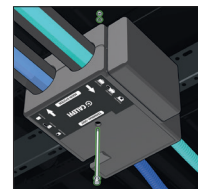

Dynamic balancing and regulating devices

Commissioning

Using different positions of the three-way ball valves (hereinafter referred to as valve A and valve B), different operation configurations can be obtained.

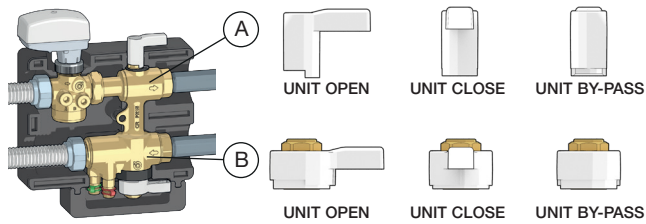

1) Washing in by-pass

Clean the main circuit, by simple washing or using specific products, with the exception of the single terminal unit. Place both lever A and lever B on "UNIT BY-PASS".

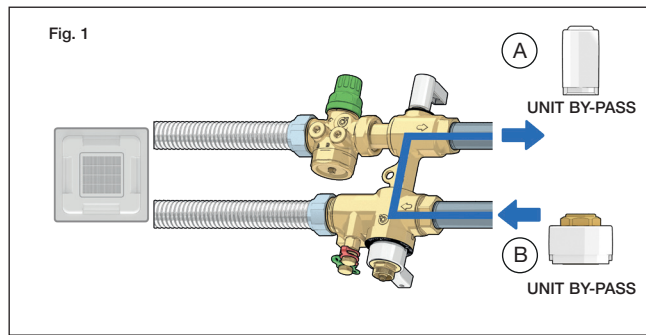

2) Terminal unit washing

Position lever A at "UNIT OPEN" and lever B at "UNIT CLOSE", screw on the rubber hose and unscrew the drain cock.

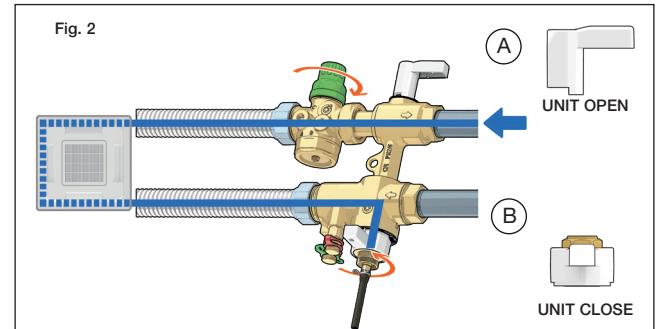

3) Strainer cleaning

To clean the strainer position both levers on "UNIT CLOSE".

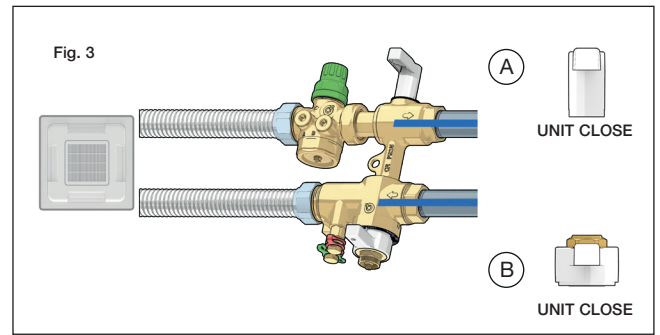

Main applications - Connection kit for terminal units

✓ circuits serving fan-coils and cooling beams

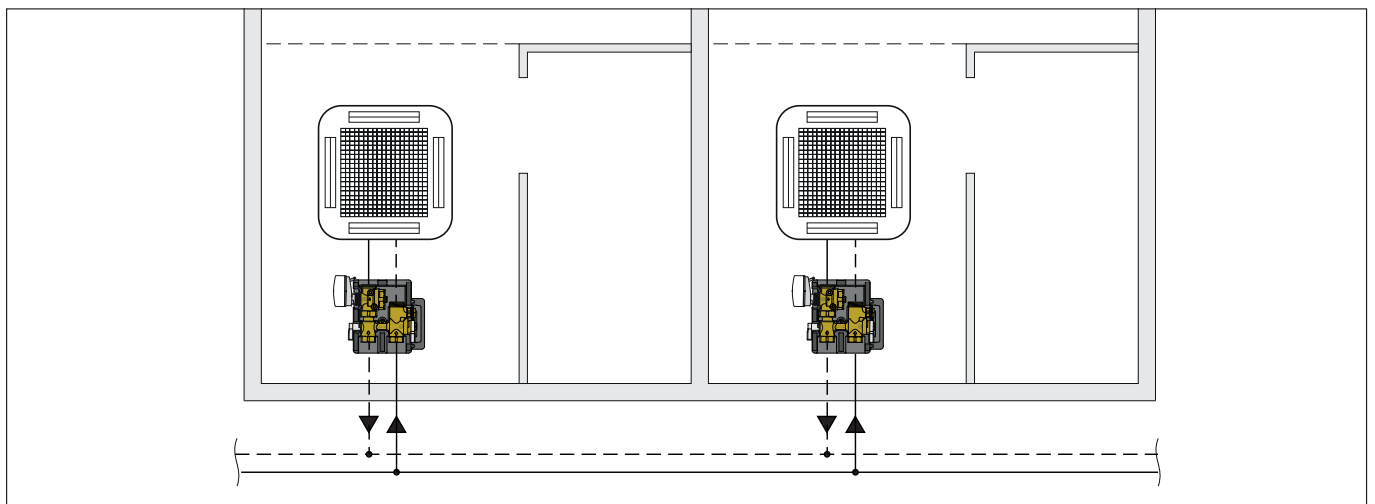

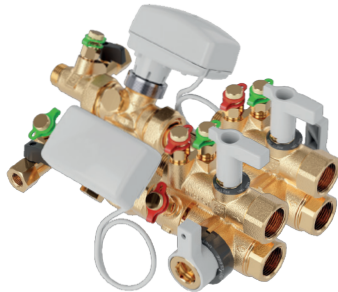
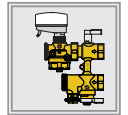
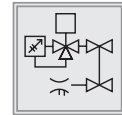

tech. broch. 01349

Operating principle

The kit layout is shown in the diagram below:

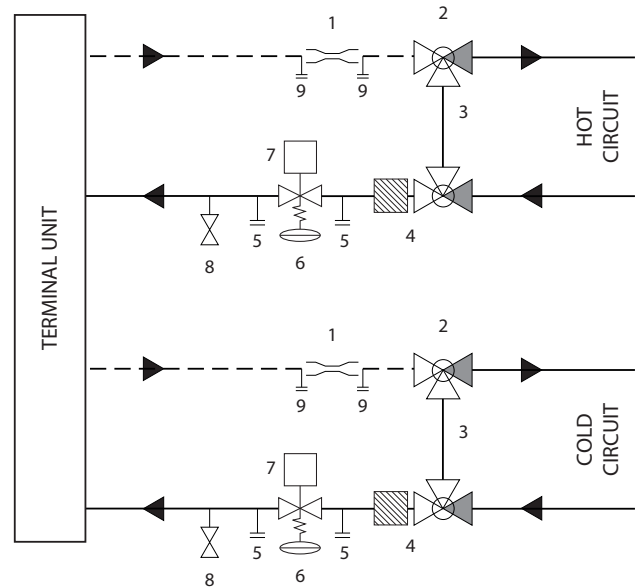

Product range

149 series Connection and regulation kit

Function

The pre-assembled kit for terminal units is compact and able to shut off, adjust and filter the secondary circuit of the terminal unit. It also allows to perform maintenance and setting operations of the system. It allows the connection of fan-coils, cooling beams or ceiling-mounted air-conditioning systems to the main distribution system. The compact size of this kit makes it ideal for installation in systems with 4 pipes and terminal units with a condensation collection tank. Complete with Venturi device for flow rate measurement.

Performance

Medium:	water, glycol solutions
Maximum percentage of glycol:	50 %
Maximum working pressure:	25 bar
Maximum differential pressure with actuators code 145013 and 6565 series actuator:	4 bar
Working temperature range:	-10–120 °C
Nominal Δp operating range:	25–400 kPa
Flow rate regulation range:	0,02–1,2 m ³ /h
PICV accuracy:	± 5 % of the set point
Strainer mesh size:	800 μ m

Characteristic components

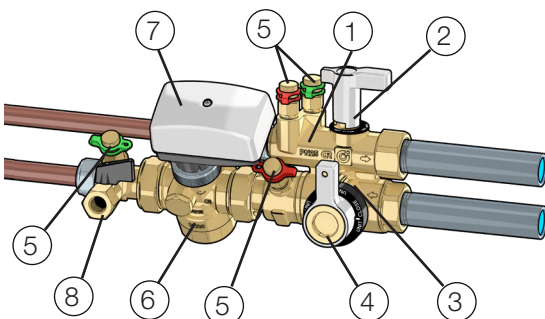

1. Venturi device for flow rate measurement with connections for pressure test ports
2. Three-way shut-off valve
3. By-pass
4. Three-way shut-off valve with built-in strainer
5. Pressure test ports
6. Pressure independent control valve (PICV)
7. Actuator (optional)
8. Filler/drain cock

1. Venturi device for flow rate measurement with connections for pressure test ports
2. Three-way shut-off valve
3. By-pass
4. Shut-off valve with built-in strainer
5. PICV pressure test ports
6. Pressure independent control valve (PICV)
7. Actuator (optional)
8. Filler/drain cock
9. Venturi pressure test ports

The kit allows you to:

- regulate and maintain the flow rate of the terminal unit constant as the differential pressure conditions of the main circuit change by means of the pressure independent control valve PICV (6);
- isolate the terminal unit through the three-way shut-off valves (2-4);
- divert the flow through the three-way shut-off valves (2-4) and the integrated by-pass (3);
- filter the inlet water to the terminal unit through the strainer located inside the shut-off valve (4);
- measure the flow rate passing through the terminal unit using the Venturi effect device with the pressure test ports (9), which make it easy to connect the measuring instrument;
- clean the circuit and drain the water through the drain cock (8).

Dynamic balancing and regulating devices

Construction details

Three-way ball valve

The shut-off valves have been designed with three ways to minimise the dimensions and connections of the kit. The internal ball is designed to open the straight path (for normal operation), the by-pass path (for passage through the by-pass) or to completely close the passage and isolate the circuit of the terminal unit.

Integrated by-pass

The kit is equipped with a by-pass, which is an indispensable element for each terminal circuit. The by-pass allows to:

- perform the flushing, washing and cleaning operations of the main circuit pipes without the medium passing through the terminal unit;
- shut off and carry out maintenance operations on the terminal unit.

Built-in strainer

The cartridge strainer in the kit mechanically blocks the impurities in the thermal medium (before they reach the terminal unit) and captures them by mechanical selection through a specific metal filter mesh.

Flow rate meter

The kit contains a flow rate metering device based on the Venturi effect. The possibility of measuring the flow rate in a simple way facilitates system setting and commissioning operations.

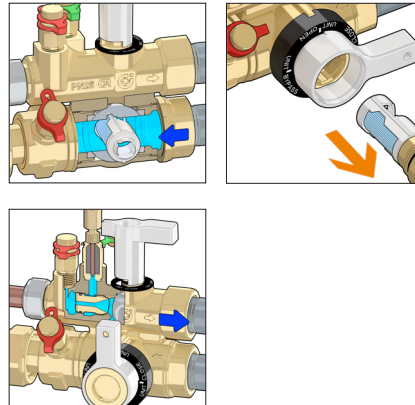

Commissioning

Using different positions of the three-way ball valves (hereinafter referred to as valve A and valve B), different operation configurations can be obtained.

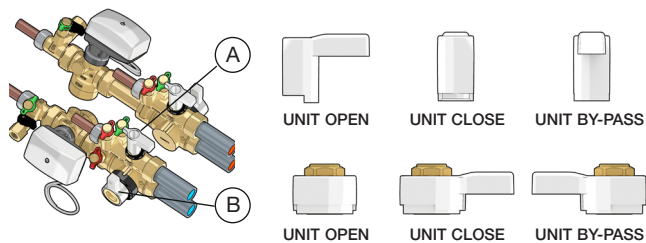

1) Washing in by-pass

Clean the main circuit, by simple washing or using specific products, with the exception of the single terminal unit.

Place both lever A and lever B on "UNIT BY-PASS".

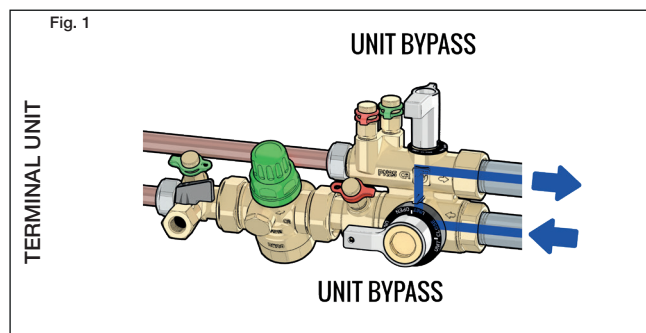

2) Terminal unit washing

Position both levers at "UNIT OPEN", close the PICV using the knob and open the drain cock: in this way it is possible to flush the terminal unit using water from the main circuit without it passing through the PICV (Fig. 2).

In cases where it is necessary, it is possible to wash the terminal unit even with the configuration shown in fig.2. In this case, set lever A to "UNIT CLOSE" and lever B to "UNIT BY-PASS".

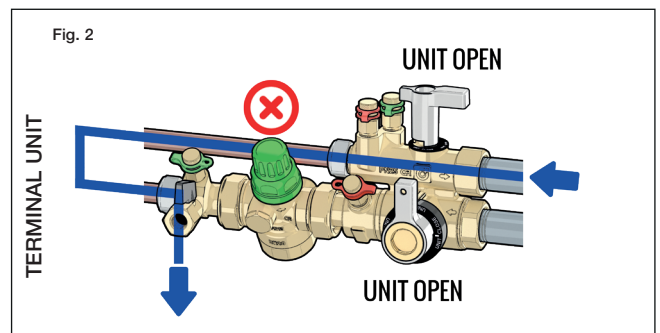

3) Strainer cleaning

To clean the strainer position both levers on "UNIT CLOSE".

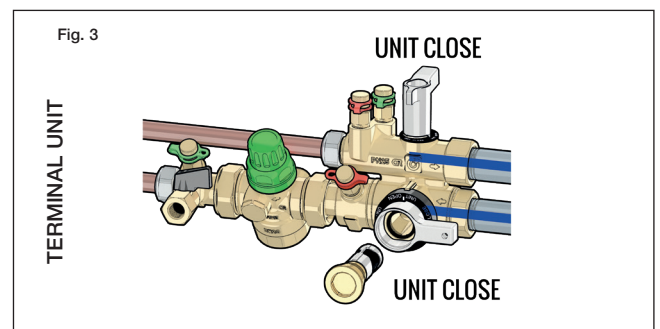

CAUTION:

Since it has no insulation, provide a suitable condensation collection system.

DIFFERENTIAL PRESSURE CONTROL

Continuous regulation of the flow rate to track the requirements for adaptation to variable thermal loads causes constant changes in the differential pressure on the terminal. To solve problems of noise emissions, over-stressing of the components and rapid wear of the system, suitable devices should be installed to regulate and control the differential pressure in the various points of the distribution circuit. There are essentially two methods for this type of control:

- **Δp control devices in by-pass.** These are simple conventional devices designed to control systems operating with fixed speed pumps having globally constant flow rates. In these applications control of the return temperature from the circuit to the central heating system is secondary to the solution's simplicity and economy.
- **in-line Δp control devices.** These are more complex devices designed to control systems operating with variable speed pumps and globally variable flow rates. In these applications, control of the return temperature from the circuit to the central heating system is optimal, as required in systems with condensing boilers or connected to district heating networks.

Δp control in by-pass

The job of the by-pass valve is to maintain the pump operating point as close as possible to its nominal value. Starting from a situation of circuit that is manually balanced at the individual terminal without the use of the by-pass valve, when the flow rate in the circuit decreases due to partial closure of the two-way valves, pressure drops increase in the circuit.

The by-pass valve, set to the nominal head value of the pump, makes it possible to limit the pressure increase, by-passing flow rate ΔG . This behaviour is guaranteed at any closing condition of the system regulating valves. In fact, once the position of the valve control knob has been established, the operating pressure value is more or less constant as the discharge flow rate varies.

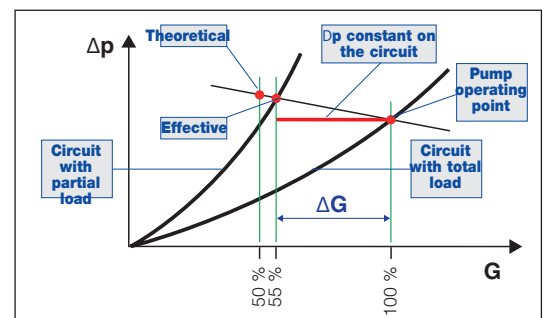
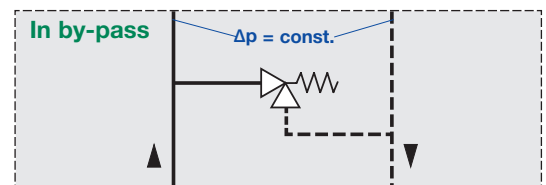
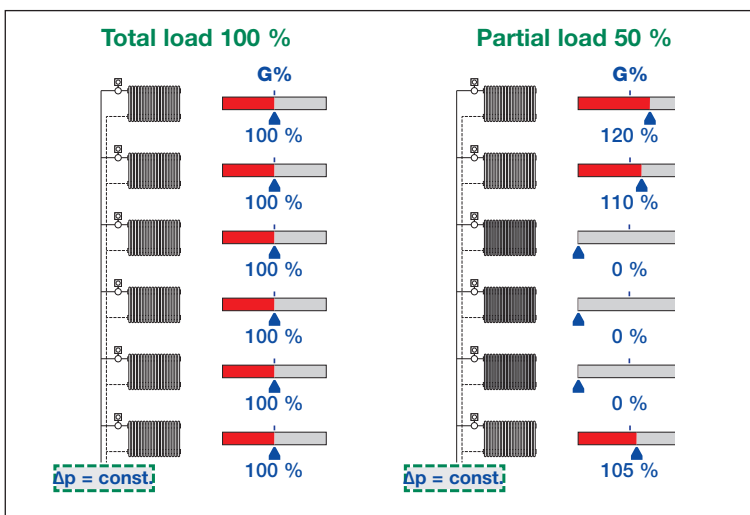

In-line Δp control

The circuit is regulated through the combined action of two devices: the balancing valve and the Δp regulator. Through a capillary pipe that connects them, they work to control the flow rate and differential pressure in the relevant circuit zone, while the operating conditions for the entire system vary. Starting from a situation of circuit that is manually balanced at the individual terminal, gradual closing of the ambient temperature control devices, e.g. thermostatic valves, causes an increase in the pressure differential between flow and return of the circuit zone. The in line regulator uses the flow pressure signal received on a capillary tube and closes the passage of the medium to absorb the pressure differential increase that has arisen and return to the set value.

The pressure differential value is kept constant between flow and return of the circuit zone, even when, according to the inverse physical process, the thermostatic valves open to increase the flow rate to the radiators.

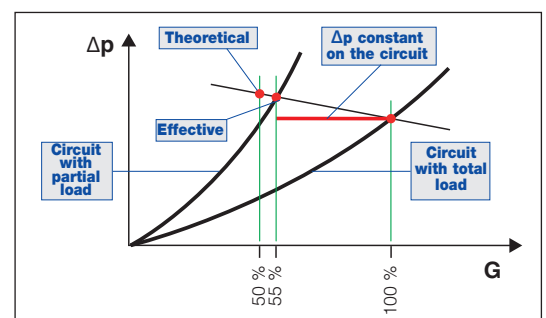
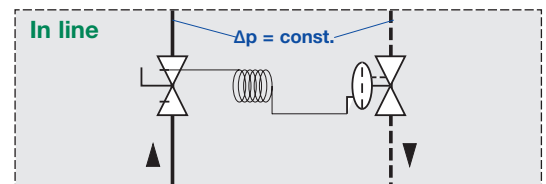
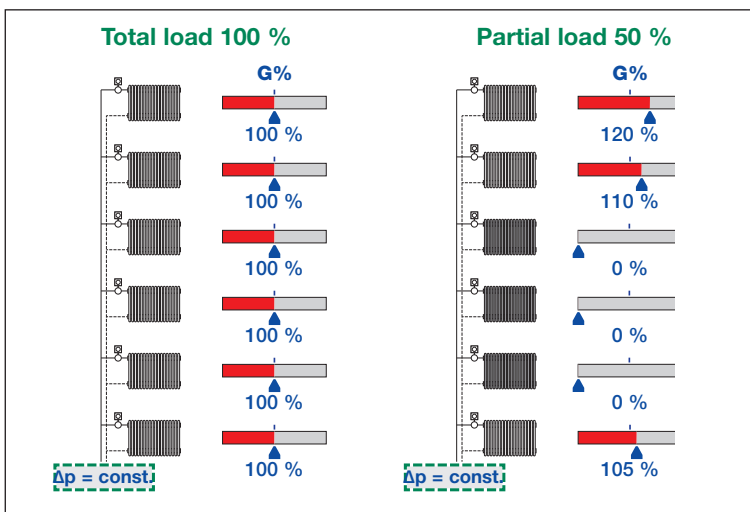

Differential pressure regulating devices

- Differential by-pass valve

518-519 series

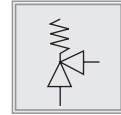

518 [tech. broch. 01410](#)

Adjustable differential by-pass valve with graduated scale.
 Max. working pressure: 10 bar
 Working temperature range: 0–110 °C
 Max. percentage of glycol: 30 %

Code	Setting range m w.g.	
518500	3/4"	1–6
518002	Ø 22	1–6



519 [tech. broch. 01007](#)

Adjustable differential by-pass valve with graduated scale.
 Max. working pressure: 10 bar
 Working temperature range: 0–110 °C
 Max. percentage of glycol: 30 %



Code	Setting range m w.g.	
519500	3/4"	1– 6
519504	3/4"	10–40
519700	1 1/4"	1– 6
519703	1 1/4"	5–25
519002	Ø 22	1– 6

Operating principle

When the compression spring (1) is adjusted using the control knob (2), the force acting on the obturator (3) changes, thus modifying the differential activation pressure value of the valve. The obturator only opens, activating the by-pass circuit, when it is subjected to a differential pressure sufficient to generate a greater thrust than that exerted by the counter-spring. This allows the flow discharge through the outlet (4), limiting the difference in pressure between the two points in the system where the valve is fitted.

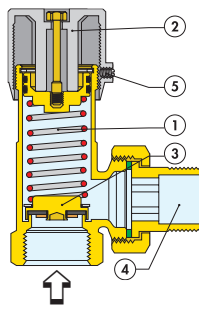

518 [tech. broch. 01007](#)

Adjustable differential by-pass valve with graduated scale.
 Max. working pressure: 10 bar
 Working temperature range: 0–100 °C
 Max. percentage of glycol: 30 %

Code	Setting range m w.g.	
518015	3/4"	1–6

Main applications - By-pass valves

- ✓ simple circuits with constant overall flow rate with thermostatic valves, of limited extension
- ✓ circuits with constant speed pumps

- ✓ circuits with conventional type generators
- ✓ heat pump systems

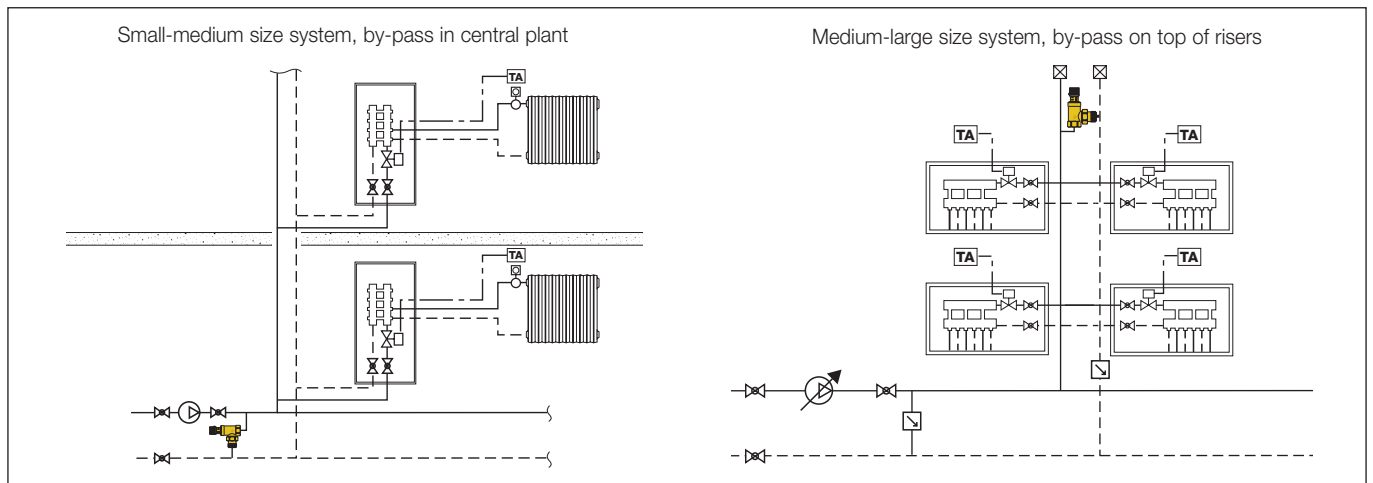

Differential by-pass valve application diagram

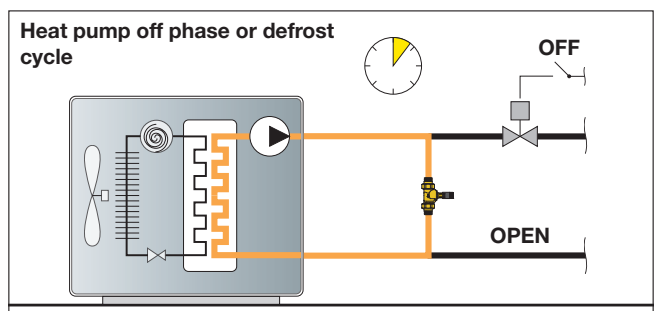
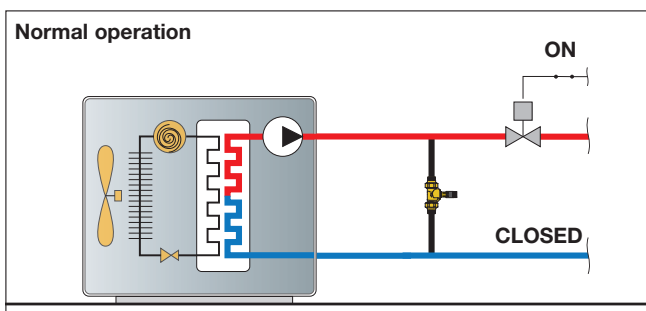

Differential pressure regulating devices

- Differential pressure regulating valve

140 series

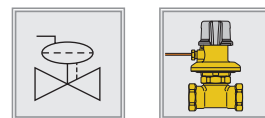

- Shut-off and preset valve

142 series

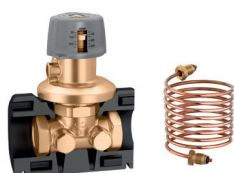
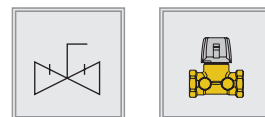

140

tech. broch. 01250

Differential pressure regulating valve.
CR dezincification resistant alloy body.
 Complete with capillary pipe to connect to the valve on the flow pipe.
With insulation.

Code			Adjustable differential pressure setting (mbar)
140340*	DN 15	1/2"	50–300
140440*	DN 15	1/2"	250–600
140350*	DN 20	3/4"	50–300
140450*	DN 20	3/4"	250–600
140360*	DN 25	1"	50–300
140460*	DN 25	1"	250–600
140370*	DN 32	1 1/4"	50–300
140470*	DN 32	1 1/4"	250–600
140380*	DN 40	1 1/2"	50–300
140480*	DN 40	1 1/2"	250–600
140392	DN 50	2" (without insulation)	50–300
140492	DN 50	2" (without insulation)	250–600

* Also available as a version without insulation

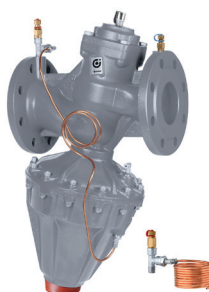

140

Differential pressure regulating valve.
 Cast iron body.
 Complete with quick-fit pressure test ports.
 Flanged PN 16 connections.
 To be coupled with counterflange EN 1092-1.

Code			Adjustable differential pressure setting (mbar)
140506	DN 65		200– 800
140606	DN 65		800–1600
140508	DN 80		200– 800
140608	DN 80		800–1600
140510	DN 100		200– 800
140610	DN 100		800–1600
140512	DN 125		200– 800
140515	DN 150		200– 800



142

tech. broch. 01250

Shut-off and preset valve.
CR dezincification resistant alloy body.
 Complete with pressure test ports for connection of the capillary pipe.
With insulation.

Code			
142140*	DN 15	1/2"	
142150*	DN 20	3/4"	
142160*	DN 25	1"	
142170*	DN 32	1 1/4"	
142180*	DN 40	1 1/2"	
142290	DN 50	2" (without insulation)	

* Also available as a version without insulation

Technical specifications

Performance

Medium:	water, glycol solutions
Max. percentage of glycol:	50 %
Maximum working pressure:	- 142 series: 16 bar
	- 140 series (DN 15–DN 25): 16 bar
	- 140 series (DN 32–DN 50): 10 bar
	- 140 series (DN 65–DN 150): 16 bar

Working temperature range: -10–120 °C

Diaphragm maximum differential pressure (140 series):

- (DN 15–DN 25)	6 bar
- (DN 32–DN 50)	2,5 bar
- (DN 65–DN 150)	16 bar

Accuracy (140 and 142 series): ± 15 %

Operating principle

The flow pressure value is brought to the top surface of the diaphragm (1) by means of the connecting capillary pipe (2); the return pressure value is brought to the bottom surface of the diaphragm through the connecting passage inside the control stem (3). The force generated by the pressure differential on the diaphragm exerts a thrust on the obturator stem, closing the passage of medium on the return of the circuit zone until the thrust force of the diaphragm and the counter-thrust force of the counter-spring reach equilibrium. This is the pressure differential value that is kept constant between flow and return of the circuit zone, even when the thermostatic valves open to increase the flow rate to the radiators, according to the inverse physical process.

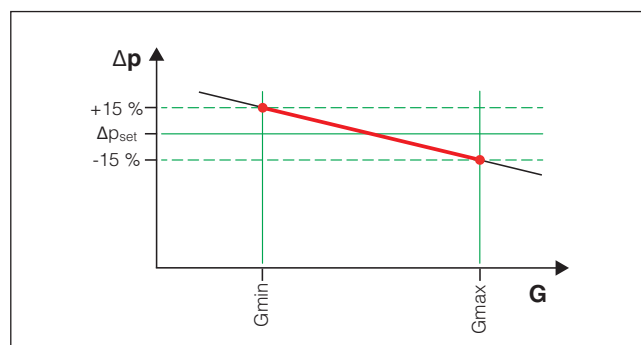
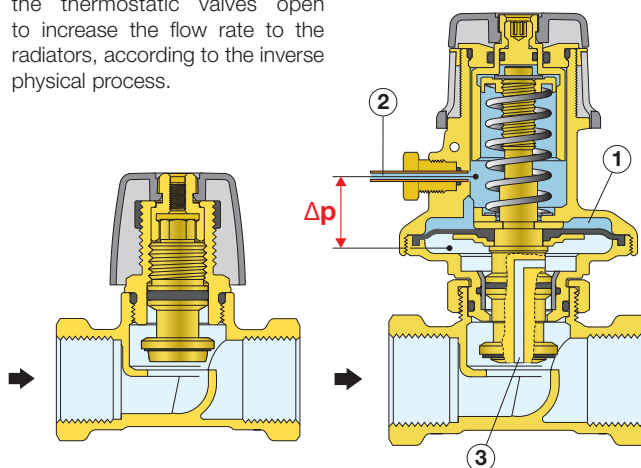

Differential pressure regulating devices

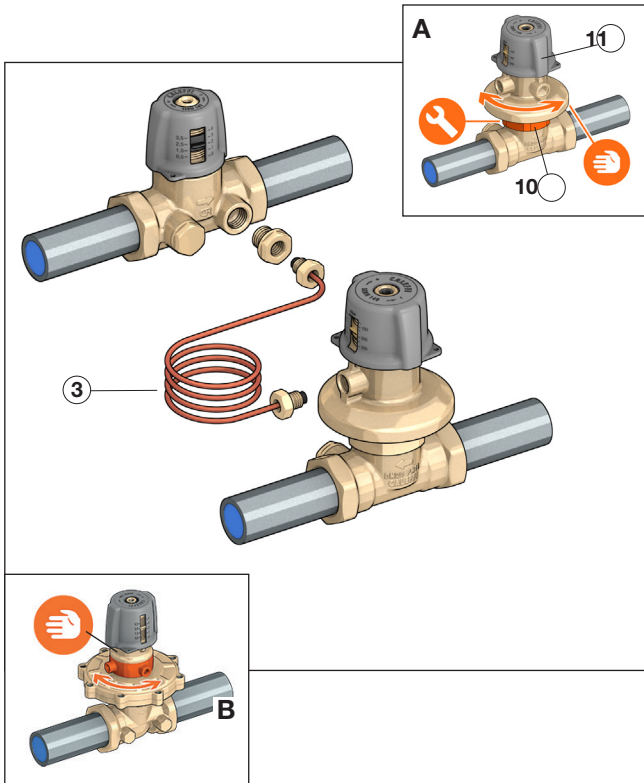

Δp indicator on 140 series

The setting process for the Δp differential regulating valve is simplified by the presence of a mobile indicator (12) and a graduated scale (13) in mbar shown on the valve knob.

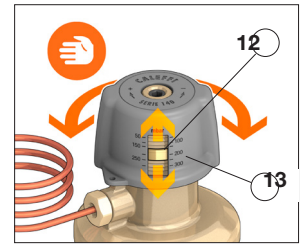

Main applications - Regulators for Δp

- ✓ variable flow rate circuits with thermostatic valves, in extended networks
- ✓ circuits with variable speed pumps

- ✓ circuits with condensing boiler type generators or district heating
- ✓ circuits with modulating regulating valves with high control requirements

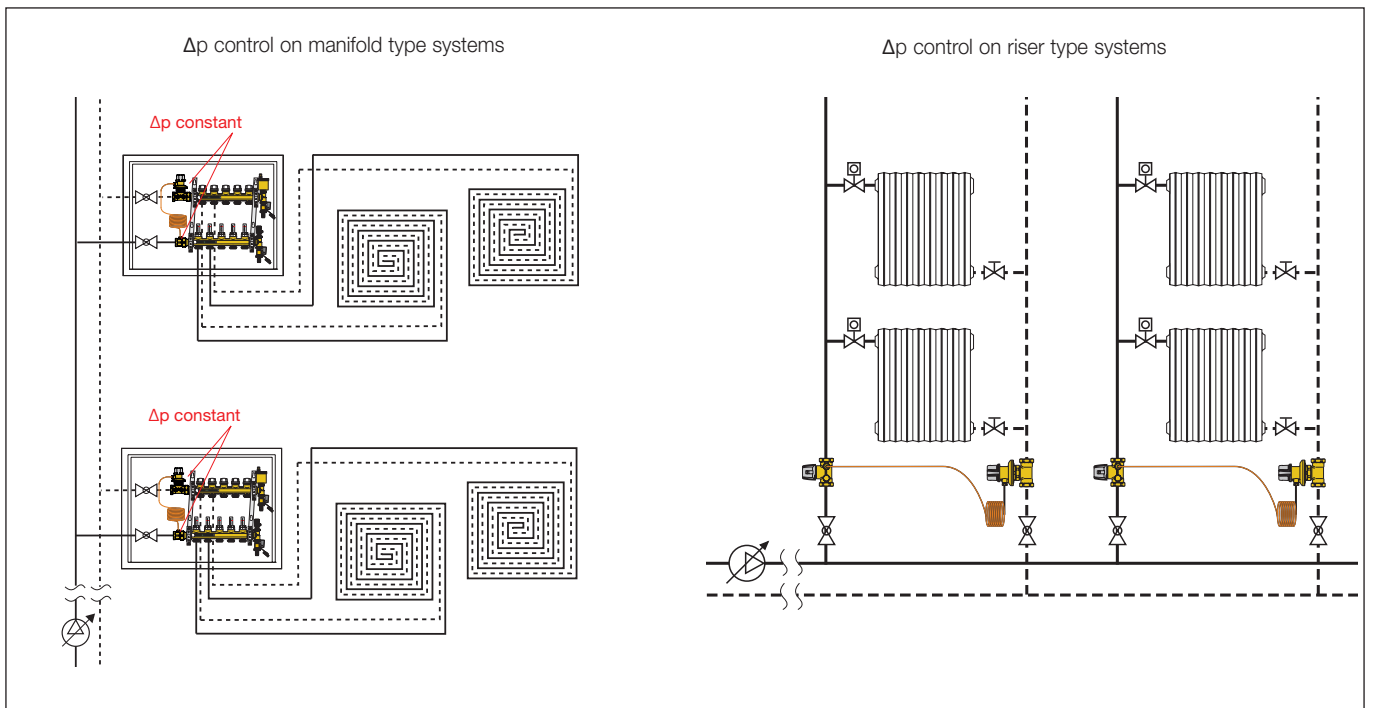

COMMISSIONING

After selecting and installing the components, the system commissioning stage is of fundamental importance for correct operation. In practice, the first requirement is to prepare the system with the specific medium flow rate and temperature measuring devices. Then the regulating and balancing devices must be adjusted to ensure the hydraulic circuit is operating in the design conditions.

- Fully open all the regulating valves, all the circuits and all the devices.
- Set the static and dynamic balancing valves to the required flow rate value.

In this delicate stage the choice of the measuring instruments and optimal use of the same in accordance with specific procedures may prove decisive for the purpose of rapid and accurate system set-up.

Electronic flow rate and differential pressure measuring station 130 series

The electronic measuring station makes it possible to measure the water flow rate in heating and cooling systems. The system consists of a Δp measuring sensor and a remote control unit (terminal) including the Caleffi Balance programming software. The terminal can be supplied already in the package or you can use your own Android® device by downloading the special app.

The sensor measures the differential pressure and communicates with the terminal via Bluetooth®. The software also contains data for the most widely available balancing valves.



Caleffi Smart Balancing

Smartphone app available.

Download the version for your Android® mobile phone.

Product range

Code 130006 Electronic flow rate and differential pressure meter complete with remote control unit, with Android® application

Code 130005 Electronic flow rate and differential pressure meter without remote control unit, with Android® application

Technical specifications

Range of measurement

Differential pressure:	0–1,000 kPa
Static pressure:	< 1000 kPa
System temperature:	-30–120 °C

Measurement accuracy

Differential pressure:	< 0,1 % of full scale
------------------------	-----------------------

Sensor

Battery capacity:	6600 mAh
Operating time:	35 hours of continuous operation
Charging time:	6 hours
IP class:	IP 65

Ambient temperature of the instrument

During operation and charging:	0–40 °C
During storage:	-20–60 °C
Ambient humidity:	maximum 90 % relative humidity

Sensor weight:	540 g
Full case:	2,8 kg

Characteristic components

- Measuring sensor
- 2 measuring pipes
- 2 measuring needles
- Touchscreen terminal with active licence and accessories
- Sensor battery charger
- Terminal battery charger
- Communication cable between terminal and PC
- Instructions with licence to download the Android® application (for code 130005)
- Instruction manual
- Instruction manual (electronic file), measurement and balancing software, valve database and report viewing tool.
- Calibration protocol. The sensor is supplied with a specific calibration protocol drawn up by a specialised laboratory.

Operating principle

The operator chooses the balancing valve from the list on the terminal (manufacturer, model, size and position with the corresponding Kv). The valve data and the measured Δp provide the basis for calculating the flow rate that is displayed on the terminal screen. If the valve on which you are taking the measurement is not available in the database, it is still possible to enter the Kv value manually.

Methods of measurement

The complete device allows to choose 3 methods of measurement:

- 1) Measurement with set position. The display shows the flow rate calculated by the device in relation to the chosen valve and assigned position.
- 2) Measurement with set flow rate. The position is calculated to assign to the valve in order to obtain the desired flow rate.
- 3) Simple Δp measurement. The screen shows the differential pressure value measured by the sensor.

Characteristic components of the Δp meter

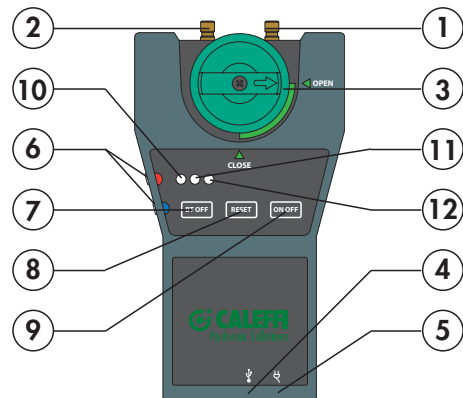

- | | |
|--|--------------------------------|
| 1. Upstream pressure test port | 7. Bluetooth® off |
| 2. Downstream pressure test port | 8. Reset button |
| 3. Setting by-pass knob | 9. ON/OFF button |
| 4. Mini USB port | 10. Bluetooth® on indicator |
| 5. Socket for charging | 11. Battery charging indicator |
| 6. Ports for temperature probes (optional) | 12. ON/OFF indicator |

Radiator circuit balancing devices

Static balancing

Static-type devices are conventional devices suitable for use in constant flow rate circuits or circuits subject to limited load variations. With static-type devices, the individual radiators are difficult to balance perfectly and have operating limitations in the case of partial closure by means of the regulating valves. The flow rate in the open circuits does not remain constant at the nominal value.

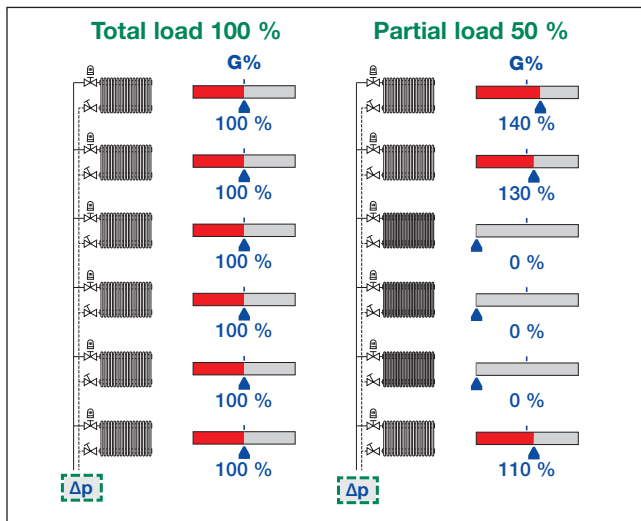
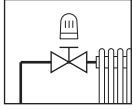

Dynamic balancing

Dynamic devices are modern automatic devices, mainly suitable for variable flow rate systems with thermal loads that change frequently. They can balance the circuit automatically, ensuring each radiator receives the design flow rate. Even in the case of partial circuit closure by means of the regulating valves, the flow rates in the open circuits remain constant at the nominal value. This behaviour is maintained even if there is modulation of the loads; the flow rate value remains constant at the value corresponding to each partial load.

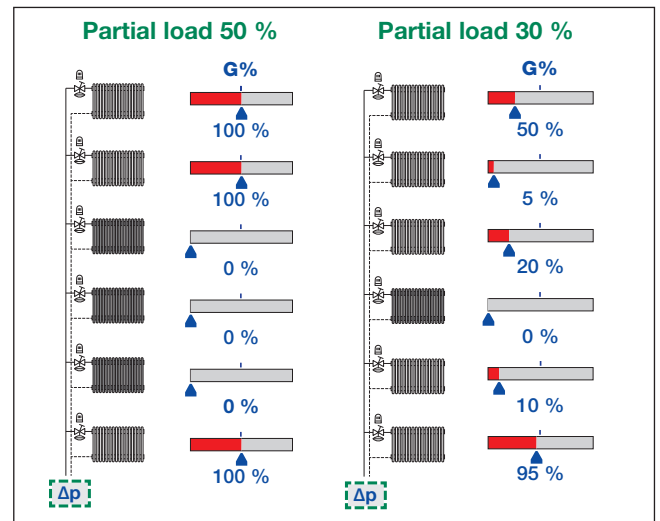
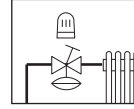

Static balancing devices

- Convertible radiator valves with pre-setting

425 - 426 - 421 - 422 series

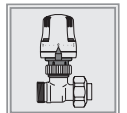
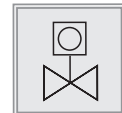

Product range

For copper, simple plastic and multi-layer pipes:
425 series Angled convertible radiator valve with preset, sizes 3/8", 1/2" radiator x 23 p.1,5 pipe

426 series straight radiator valve with preset, sizes 3/8", 1/2" radiator x 23 p.1,5 pipe

For steel pipes:

421 series Angled convertible radiator valve with preset, sizes 3/8", 1/2" and 3/4" (*)

422 series Straight convertible radiator valve with preset, sizes 3/8", 1/2" and 3/4" (*)

* 3/4" with tailpiece without rubber seal

Operating principle

The convertible radiator valves with pre-setting are equipped with an internal device that enables the presetting of hydraulic pressure drop characteristics.

The selector locking nut enables you to select the specific cross sections in such a way as to create the desired resistance to the motion of the medium.

Each cross section equates to a specific Kv value to create the pressure drop corresponding to a given setting position on a graduated scale.

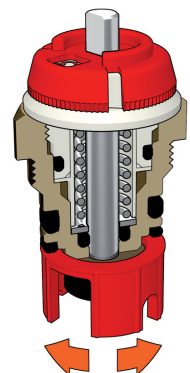

Performance

Medium:	water, glycol solutions
Maximum percentage of glycol:	30 %
Maximum differential pressure with control fitted:	1 bar
Maximum working pressure:	10 bar
Thermal medium working temperature range:	5–100 °C
Factory preset: position 5	

Pre-setting and installation of thermostatic or thermo-electric actuators

Lift the relevant selector locking nut for the pre-setting device and turn the control stem to select the desired position.

Take care not to pull out the control stem locking nut completely. The selected pre-setting number must appear perfectly in the centre of the window.

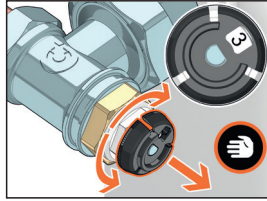

Pre-settable convertible radiator valves with 2K proportional band thermostatic control head

		Kv (m ³ /h) (2K proportional band)**					
		3/8" angled	3/8" straight	1/2" angled	1/2" straight	3/4" angled	3/4" straight
Pre-setting position	1	0.08	0,08	0,09	0,09	0.12	0.12
	2	0.15	0,15	0,16	0,16	0.20	0.20
	3	0.22	0,22	0,23	0,23	0.32	0.32
	4	0.35	0,35	0,36	0,36	0.50	0.50
	5	0.50	0,50	0,55	0,55	0.72	0.72

Main applications - Preset valves

- ✓ circuits with riser distribution
- ✓ circuits with manifold distribution

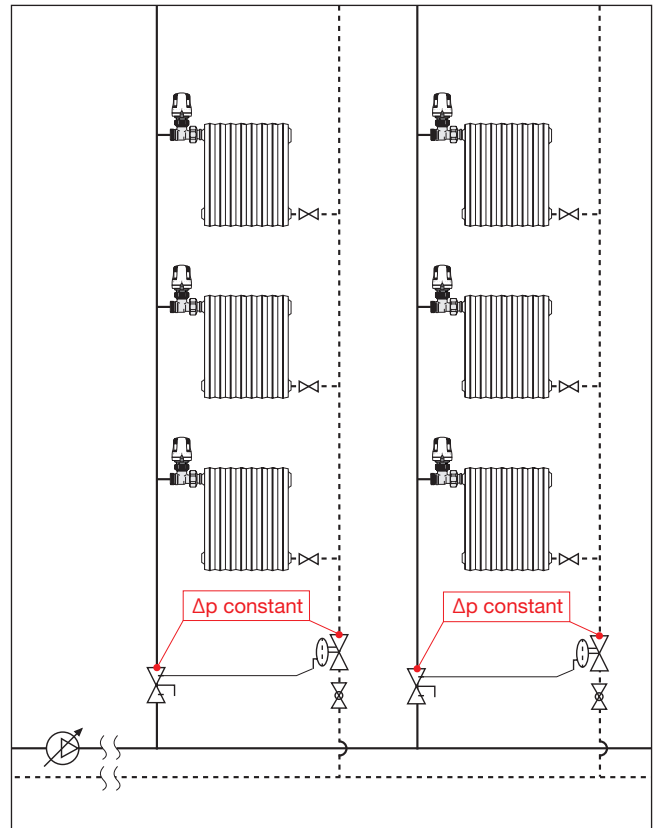

Dynamic balancing devices

- Dynamic thermostatic valves

230 series

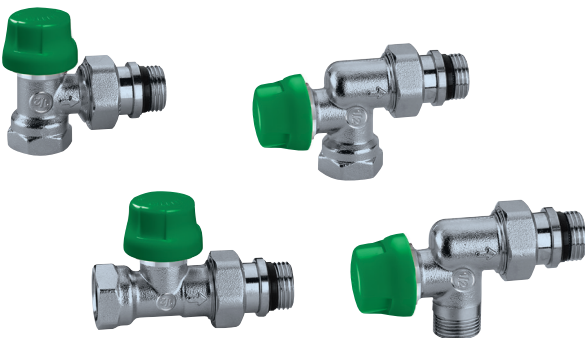
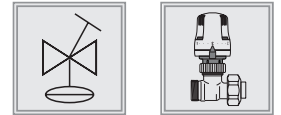

Product range

For steel pipes

230 series: sizes 3/8", 1/2" and 3/4" (*)

231 series: sizes 3/8", 1/2" and 3/4" (*)

234 series: sizes 3/8", 1/2"

For copper, simple plastic and multi-layer pipes

232 series Angled dynamic thermostatic radiator valve: sizes 3/8", 1/2" radiator x 23 p. 1,5 pipe

233 series Straight dynamic thermostatic radiator valve: sizes 3/8", 1/2" radiator x 23 p. 1,5 pipe

237 series Reverse-angled dynamic thermostatic radiator valve: sizes 3/8", 1/2" radiator x 23 p. 1,5 pipe

* 3/4" with tailpiece without rubber seal

PCT
INTERNATIONAL
APPLICATION
PENDING

Performance

Medium: water, glycol solutions
 Maximum percentage of glycol: 30 %
 Maximum differential pressure with control fitted: 1,5 bar
 Maximum working pressure: 10 bar
 Nominal Δp operating range: (reg. 1-4) 10–150 kPa
 (reg. 5-6) 15–150 kPa
 10–150 kPa low flow
 Flow rate regulation range: 20–120 l/h
 10–80 l/h low flow
 Thermal medium working temperature range: 5–95 °C
 Factory preset: position 6

Hydraulic characteristics

With thermostatic control head and 2K proportional band

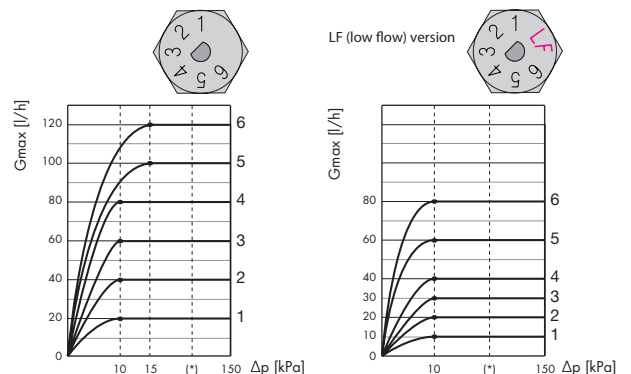

Operating principle

The dynamic thermostatic radiator valve is designed with the purpose of controlling a flow rate of thermal medium in the radiators of two-pipe heating systems that is:

- adjustable in accordance with the requirements of the part of the circuit controlled by the device;
- constant despite any variation in differential pressure conditions in the circuit.

The device, in conjunction with a thermostatic control head, combines different functions in a single component:

- A Differential pressure regulating valve, which automatically cancels the effect of the pressure fluctuations typical of variable flow rate systems and prevents noisy operation.
- B Device for pre-setting the flow rate, which allows direct setting of the maximum flow rate value, thanks to its use in conjunction with the differential pressure regulating valve.
- C Flow rate control depending on the ambient temperature, thanks to its use in conjunction with a thermostatic control head.

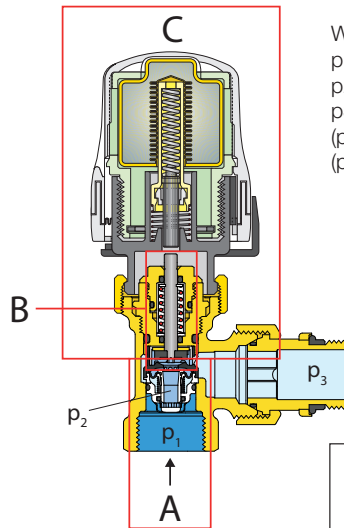

Where:

- p1 = upstream pressure
- p2 = intermediate pressure
- p3 = downstream pressure
- (p1 - p3) = total valve Δp
- (p2 - p3) = constant Δp

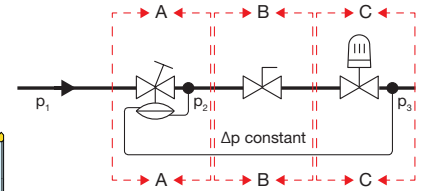

	Pre-setting position					
	1	2	3	4	5	6
G_{max} (l/h)	20	40	60	80	100	120
G_{max} (l/h) low flow	10	20	30	40	60	80
G_{2K} (l/h)	20	40	55	70	80	90
G_{2K} (l/h) low flow	10	20	30	40	55	70

Main applications - Dynamic valves

- ✓ circuits with riser distribution
- ✓ circuits with manifold distribution

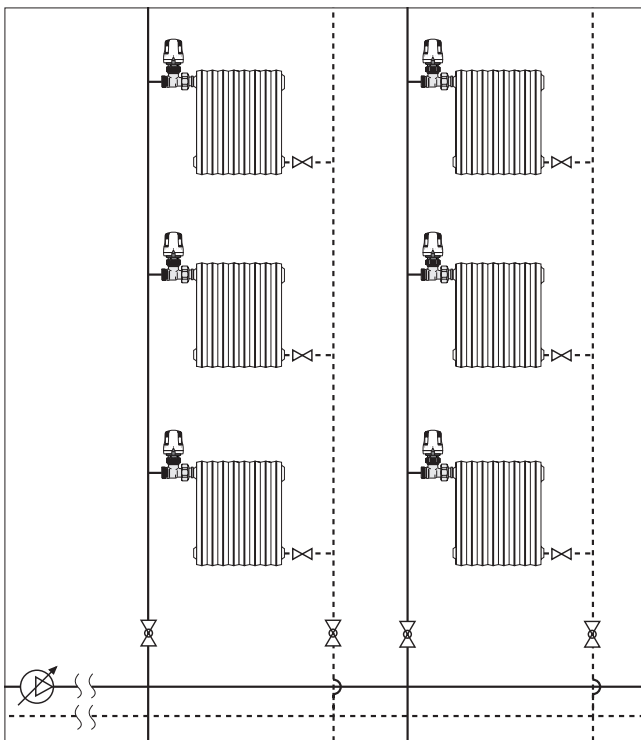

Controls for valves

Fitted for thermostatic, thermo-electric and electronic control heads

The valves are fitted for combination with thermostatic control heads and thermo-electric actuators, for regulating the ambient temperature automatically or under a room thermostat control respectively. Combining the valves with these devices guarantees considerable energy saving, since the ambient temperature is kept constant at the set value taking into consideration any gratuitous heat inputs (solar radiation or internal thermal loads).



230100

Kit for measuring Δp in the circuits with dynamic valves.

To use the instrument, the headwork replacement kit is necessary (code 387201), which allows you to extract the headwork of the dynamic thermostatic radiator valve and to insert the appropriate headwork for the measuring instrument.

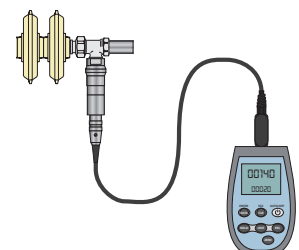

Devices for balancing panels circuit

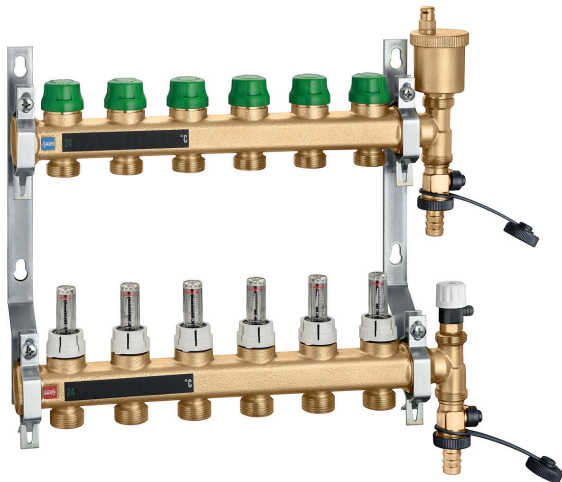

665 DYNAMICAL®

Pre-assembled manifolds.
Maximum working pressure: 6 bar.
Working temperature range: 5–60 °C.
Outlet centre distance: 50 mm.

Consisting of:

- return manifold complete with DYNAMICAL® flow regulating valves fitted for a thermo-electric actuator with a flow rate regulation range of 25–150 l/h and shut-off valves;
- flow manifold complete with flow indicator;
- end fittings with automatic air vent complete with hygroscopic safety cap and drain cock;
- steel mounting brackets for box or direct wall mounting.

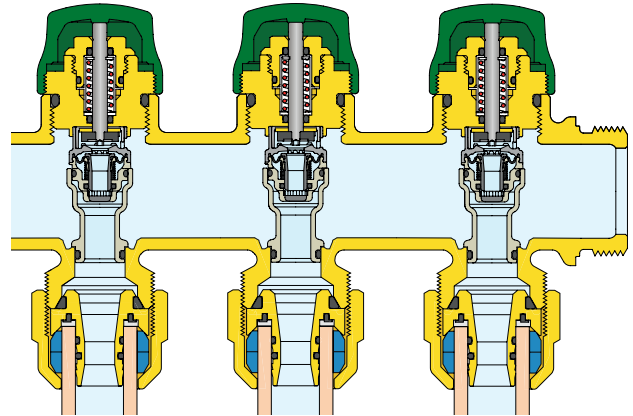

Operating principle

The dynamic manifold has been designed to control a flow rate of thermal medium in the panel circuit which is:

- adjustable in accordance with the requirements of the part of the circuit controlled by the device;
- constant despite any variation in differential pressure conditions in the circuit. The device, in conjunction with a control head, combines different functions in a single component:
 - A Differential pressure regulating valve, which automatically cancels the effect of the pressure fluctuations typical of variable flow rate systems and prevents noisy operation.
 - B Device for pre-setting the flow rate, which allows direct setting of the maximum flow rate value, thanks to its use in conjunction with the differential pressure regulating valve.
 - C Flow rate ON/OFF control depending on the ambient temperature, thanks to its use in conjunction with an electronic control head.

Main applications

- ✓ distribution circuits for panel system

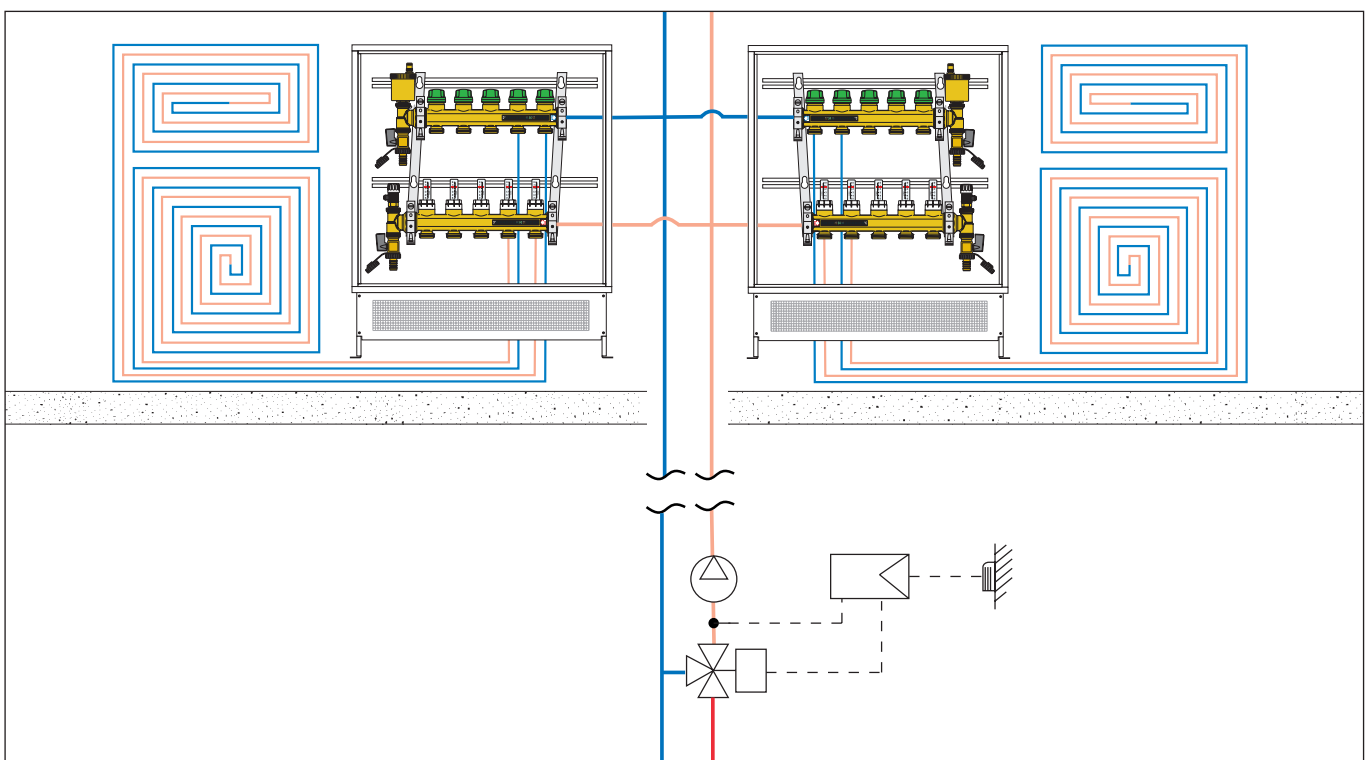

DOMESTIC WATER SYSTEMS

Balancing devices for recirculation circuits

Legionella control

According to the most recent legislation and standards, in order to prevent the growth of the dangerous Legionella bacterium in centralised domestic hot water production systems with storage, the hot water must be stored and distributed at controlled temperature values.

General rules:

- Storage $T \geq 60 \text{ }^\circ\text{C}$
- Distribution $T \geq 55 \text{ }^\circ\text{C}$
- Distribution return $T \geq 50 \text{ }^\circ\text{C}$
- Water drawn $T \leq 50 \text{ }^\circ\text{C}$
- Cold water $T \leq 25 \text{ }^\circ\text{C}$

Each recirculation circuit riser must be balanced in order to guarantee the correct

temperature.

The diagram opposite shows the behaviour of Legionella Pneumophila bacteria as the temperature conditions of the water containing the bacteria change.

To ensure correct thermal disinfection, it is necessary to go up to values of at least $60 \text{ }^\circ\text{C}$.

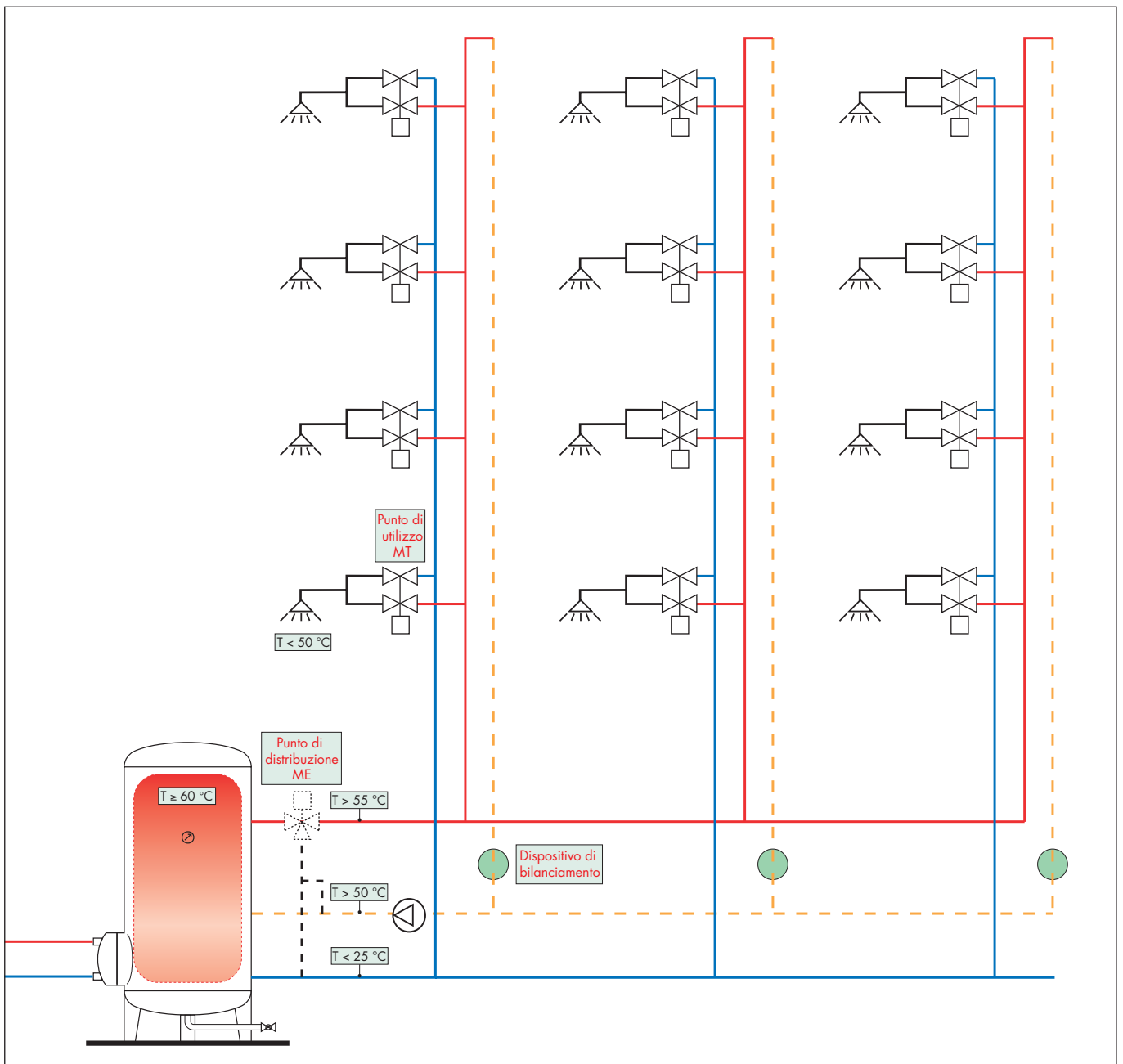
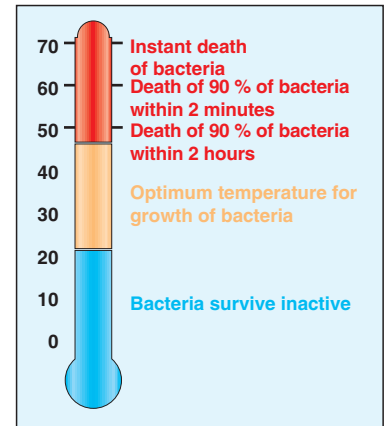

MULTI-FUNCTION THERMOSTATIC REGULATOR

- Multi-function thermostatic regulator
for domestic hot water recirculation circuits

116 series

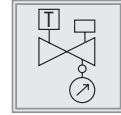

116

tech. broch. 01325



Thermostatic regulator for domestic hot water recirculation circuits. Complete with automatic thermostatic thermal disinfection function. With temperature gauge for circuit temperature checking. "LOW LEAD" dezincification resistant alloy body

Female connections. Maximum working pressure: 16 bar. Temperature adjustment range: 35–60 °C. Disinfection temperature: 70 °C.



Code	DN	Connection
116240	15	Rp 1/2"
116250	20	Rp 3/4"
116260	25	Rp 1"
116270	32	Rp 1 1/4"

116000

tech. broch. 01325



Insulation for 116 series thermostatic regulators.

Code	Utilisation
CBN116140	1/2"-3/4"
CBN116160	1"-1 1/4"

116000

tech. broch. 01325



Cartridge for actuator-controlled thermal disinfection function. For use with 116 series **in conjunction with 656 controls..**

Code
116000

116

tech. broch. 01325



Thermostatic regulator for domestic hot water recirculation circuits. Fitted for automatic or controlled thermal disinfection function. With pocket for temperature gauge. "LOW LEAD" dezincification resistant alloy body

Female connections. Maximum working pressure: 16 bar. Temperature adjustment range: 35–60 °C.



Code	DN	Connection
116140	15	Rp 1/2"
116150	20	Rp 3/4"
116160	25	Rp 1"
116170	32	Rp 1 1/4"

116

tech. broch. 01325



Dial temperature gauge accessory for 116 series multi-function thermostatic regulator. Temperature gauge scale: 0–80 °C.

Code
116010

Multi-function thermostatic regulator

Operating principle

In domestic hot water distribution circuits, to respect modern plant requirements for the prevention of Legionellas' disease, it is essential to ensure that all sections are kept at the correct temperature. The recirculation network must be balanced to prevent non-uniform temperature distribution, which results in cold sections and the risk of Legionella proliferation. The thermostatic regulator, installed on each branch of the recirculation circuit, automatically maintains the set temperature. This device modulates the medium flow rate in accordance with the water inlet temperature by means of the action of a dedicated internal thermostatic cartridge. When the water temperature approaches the set value, the obturator progressively reduces the passage. The medium flow rate supplied by the recirculation pump is thus distributed to the other network branches, resulting in effective automatic thermal balancing.

1- Thermostatic regulation

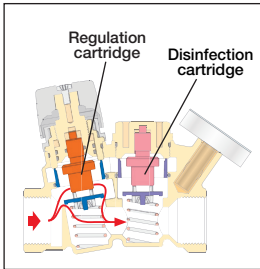

2- Minimum flow rate

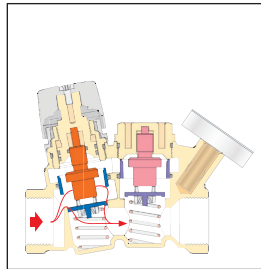

3- Thermostatic disinfection

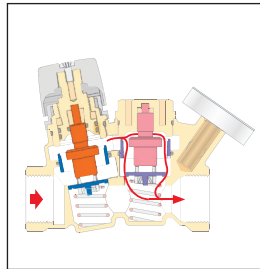

4- Thermal closure

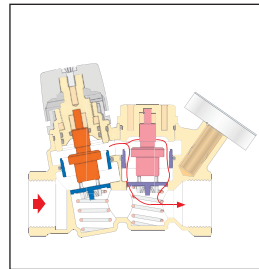

5- Electrically controlled disinfection

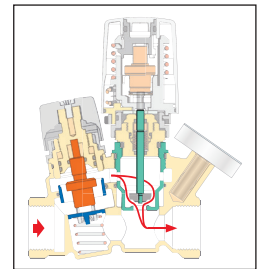

116 series thermostatic regulators diagram

The regulator operating modes as the temperature of the water in the circuit to which the regulator is fitted changes are shown below.

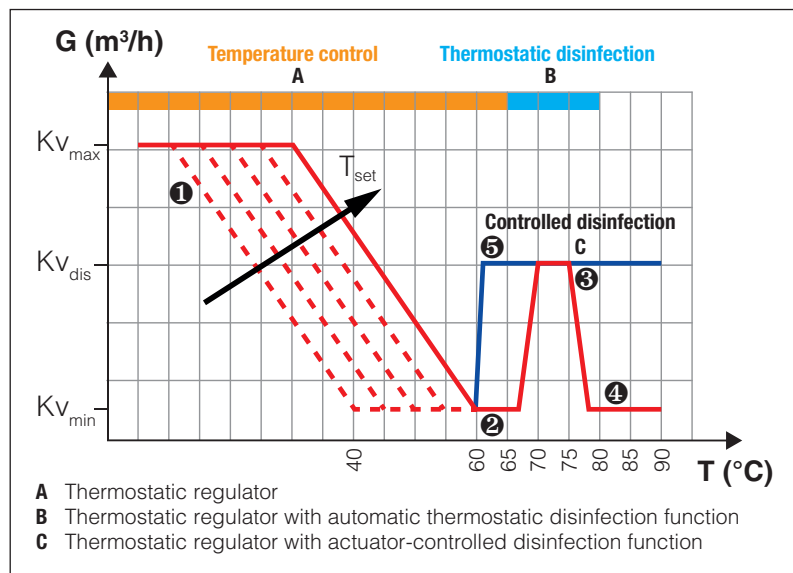

Thermal disinfection

If necessary, the regulator is already equipped with a thermal disinfection function, which is useful if the system temperature needs to be increased to values over 55–60 °C.

The automatic thermal disinfection function is activated by a dedicated second thermostatic cartridge that trips at 70 °C. Conversely, controlled thermal disinfection is activated by a thermo-electric actuator.

Replacing the cartridge for electrically controlled disinfection

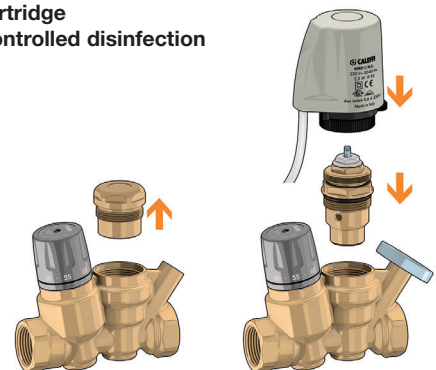

Thermostatic regulator for domestic hot water recirculation circuits



116

tech. broch. 01362



Thermostatic regulator for domestic hot water recirculation circuits. With temperature gauge for circuit temperature checking. "LOW LEAD" dezincification resistant alloy body CR. Female connections. Maximum working pressure: 16 bar. Temperature adjustment range: 40–65 °C.



kiwa

Code	DN	Connection
116441	15	Rp 1/2"
116451	20	Rp 3/4"



116

tech. broch. 01362



Thermostatic regulator for domestic hot water recirculation circuits. With pocket for temperature gauge. "LOW LEAD" dezincification resistant alloy body CR. Connections for copper pipe. Maximum working pressure: 16 bar. Temperature adjustment range: 40–65 °C.



kiwa

Code	DN	Connection
116415	15	Ø 15
116420	20	Ø 22



116

tech. broch. 01362



Thermostatic regulator for domestic hot water recirculation circuits. Fitted for automatic or controlled thermal disinfection function. With pocket for temperature gauge. "LOW LEAD" dezincification resistant alloy body CR. Female connections. Maximum working pressure: 16 bar. Temperature adjustment range: 40–65 °C.



kiwa

Code	DN	Connection
116440	15	Rp 1/2"
116450	20	Rp 3/4"



116000

tech. broch. 01325

Insulation for 116 series thermostatic regulators.

Code	Utilisation
CBN116440	1/2"-3/4"



116

tech. broch. 01325

Dial temperature gauge accessory for 116 series multi-function thermostatic regulator. Temperature gauge scale: 0–80 °C.

Code
116010

Operating principle

1 - Thermostatic regulation

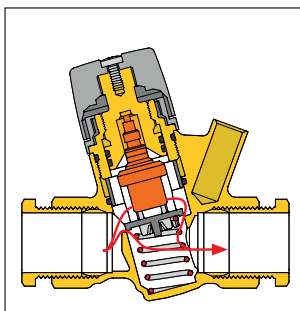

2 - Minimum flow rate

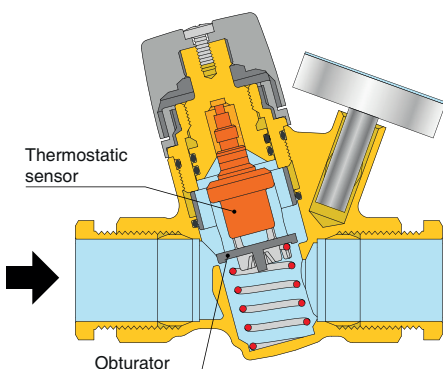
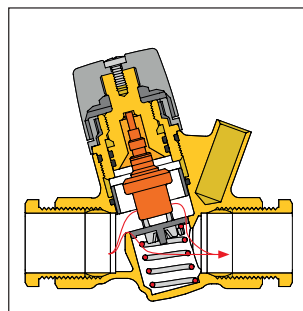

Hydraulic characteristics

The regulator operating modes as the temperature of the water in the circuit to which the regulator is fitted changes are shown below.

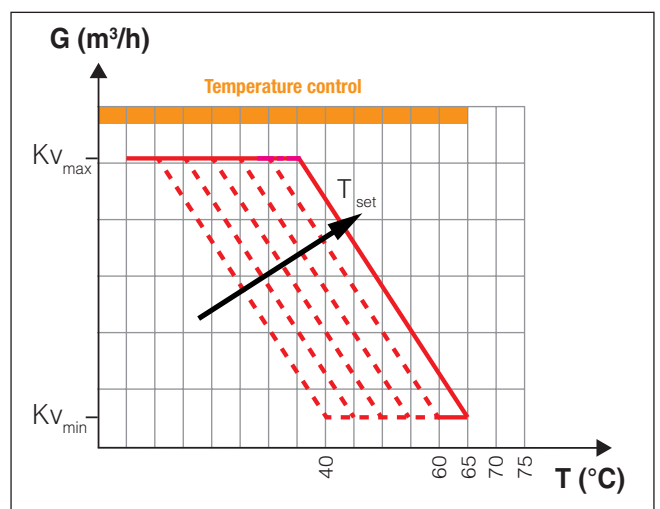

Main applications - Multi-function thermostatic regulator

✓ Balancing of domestic hot water recirculation circuits, installation on risers and branch circuits.

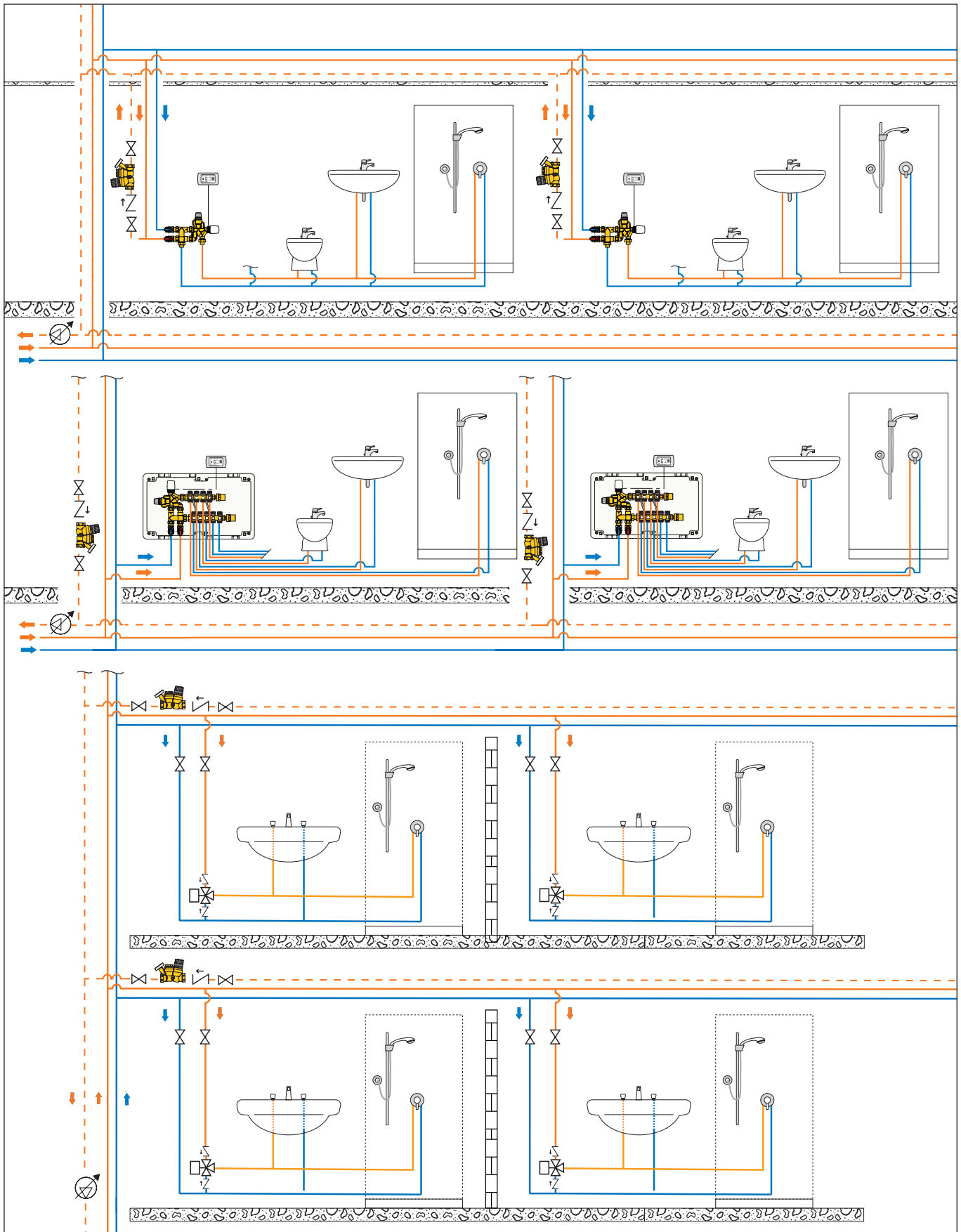

We reserve the right to make changes and improvements to our products and the related technical data in this publication, at any time and without prior notice.



CALEFFI S.p.A. · S.R.229, N.25 · 28010 Fontaneto d'Agogna (NO) · Italy
Tel. +39 0322 8491 · info@caleffi.com www.caleffi.com

© 2024 Copyright Caleffi

